

OPERATING INSTRUCTIONS

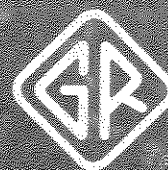

TYPE 1650-A

IMPEDANCE BRIDGE

1650

G E N E R A L R A D I O C O M P A N Y

OPERATING INSTRUCTIONS

TYPE 1650-A

IMPEDANCE BRIDGE

Form 1650-0100-E

July, 1962

Copyright 1962 by General Radio Company
West Concord, Massachusetts, USA

GENERAL RADIO COMPANY
WEST CONCORD, MASSACHUSETTS, USA

TABLE OF CONTENTS

Section 1. INTRODUCTION	1
1.1 Description	1
1.2 Symbols, Abbreviations, and Definitions	2
1.3 Series and Parallel Components	2
Section 2. PRINCIPLES OF OPERATION	
2.1 General	3
2.2 Bridge Switching	4
2.3 Compensation Techniques	4
2.4 Bridge Sources and Detectors	5
2.5 Orthonull	5
Section 3. INSTALLATION	7
3.1 Opening and Tilting the Cabinet	7
3.2 Power Supply	7
Section 4. DC MEASUREMENTS	7
4.1 Resistance Measurements Using 6-Volt Supply	7
4.2 Resistance Measurements Using External DC Supplies	8
Section 5. OPERATING PROCEDURE 1 KC MEASUREMENTS	9
5.1 Capacitance Measurement	9
5.2 Inductance Measurements	10
5.3 AC Resistance Measurement	11
5.4 Notes on AC Measurements	11
5.5 Operating Procedure with Orthonull	12
Section 6. OPERATING PROCEDURE WITH EXTERNAL AC GENERATOR	13
6.1 Procedure	13
6.2 Connection of External Generator	13
6.3 Maximum AC Voltage	14
6.4 Allowable D and Q Ranges vs Frequency	14
6.5 Corrections for Residual and Lead Impedances	14
6.6 Extending the D and Q Ranges at Low Frequencies	14
6.7 Operation Above 20 kc	15
Section 7. SPECIAL MEASUREMENTS	16
7.1 Application of DC Bias to Capacitors	16
7.2 Application of Direct Current to Inductors	17
7.3 DC Bias for AC Resistance Measurements	18
7.4 Measurement of AC Resistance with Reactance	19
7.5 Resonant Frequency of Tuned Circuits	19
7.6 Measurements on Shielded Three-Terminal Components	19
7.7 Remote Measurements	20
7.8 Measurement of Grounded Components	20
7.9 Use of the Type 1650-P1 Test Jig	20
7.10 Limit Testing	20
Section 8. SERVICE AND MAINTENANCE	21
8.1 General	21
8.2 Battery Replacement	21
8.3 Adjustments	21
8.4 Trouble-Shooting Suggestions	21
8.5 Calibration	22
PARTS LIST	24
SCHEMATIC DIAGRAM	25
APPENDIX A	27

SPECIFICATIONS

Ranges:

Resistance: 1 m Ω - 10 M Ω , 8 ranges ac or dc.

Capacitance: 1 pf - 1000 μ f, 7 ranges, series or parallel.

Inductance: 1 μ h - 1000 h, 7 ranges, series or parallel.

D (of series C): 0.001 - 1 at 1 kc.

D (of parallel C): 0.1 - 50 at 1 kc.
($C_s = C_p$ within 1% if $D < 0.1$.)

Q (of series L): 0.02 - 10 at 1 kc.

Q (of parallel L): 1 - 1000 at 1 kc.
($L_s = L_p$ within 1% if $Q > 10$.)

Accuracy:

Resistance: $\pm 1\%$ ± 1 m Ω (residual $R \approx 1$ m Ω).
(dc accuracy limited by sensitivity to $\pm 1\%$ ± 10 m Ω .
Above 100 k Ω , external dc supply required to get 1% accuracy.)

Capacitance: $\pm 1\%$ ± 1 pf (residual $C \approx 0.5$ pf).

Inductance: $\pm 1\%$ ± 1 μ h (residual $L < 0.2$ μ h).

D: $\pm 5\%$; ± 0.001 at 1 kc or lower.

1/Q: $\pm 5\%$; ± 0.001 at 1 kc or lower.

Frequency Range (1 kc supplied internally): for 1% accuracy for L and C, 20 cps to 20 kc; for R, 20 cps to 5 kc. (D and Q ranges are functions of frequency.)

Internal Oscillator Frequency (external ac and dc sources can also be used): 1 kc $\pm 2\%$.

Internal Detector: Response, flat or selective at 1 kc; sensitivity control provided.

Internal DC Supply: 6 v, 60 ma max.

Power Supply: 4 D cells, supplied. Current drain for ac measurements, 10 ma.

DC Polarization: 600 v may be applied (from external source) for series capacitance measurements.

Accessories Available: Type 1650-P1 Test Jig.

Accessories Required: None. Earphones may be used for high precision at extremes of bridge ranges.

Mounting: Aluminum cabinet, with captive cover.

Dimensions: Height 12 $\frac{3}{4}$, width 12 $\frac{1}{2}$, depth 7 $\frac{3}{4}$ inches (325 by 320 by 200 mm), including handle.

Weight: 17 lb (8 kg).

U.S. Patent Nos 2,872,639 and 2,966,257.

General Radio Experimenter reference: Volume 33, No. 3, March 1959;
"Orthonull", Volume 33, No. 4, April 1959.

Available combined as reprint No. E-108.

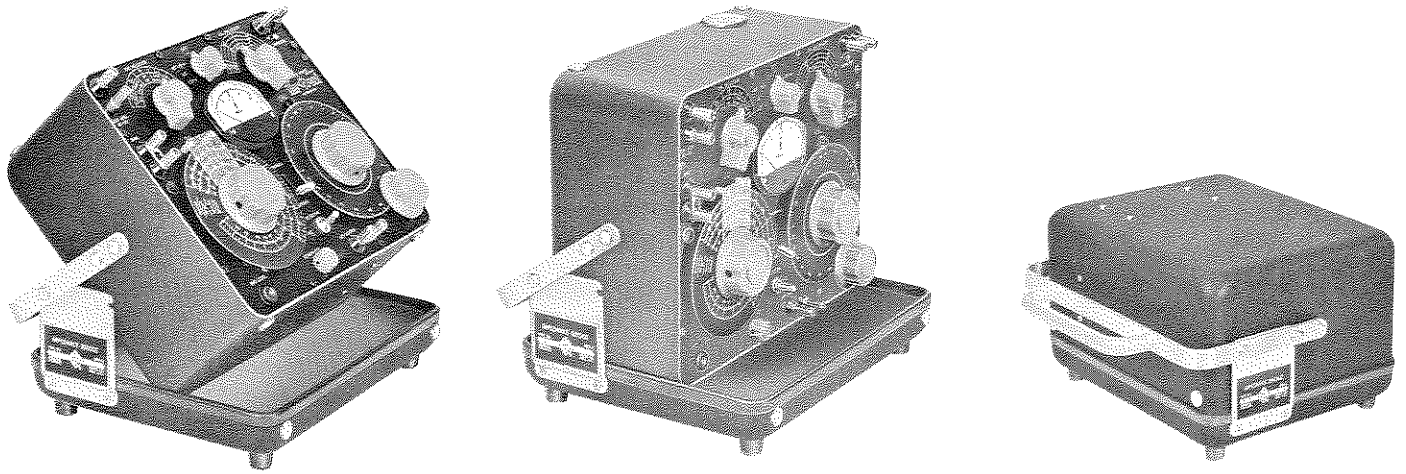
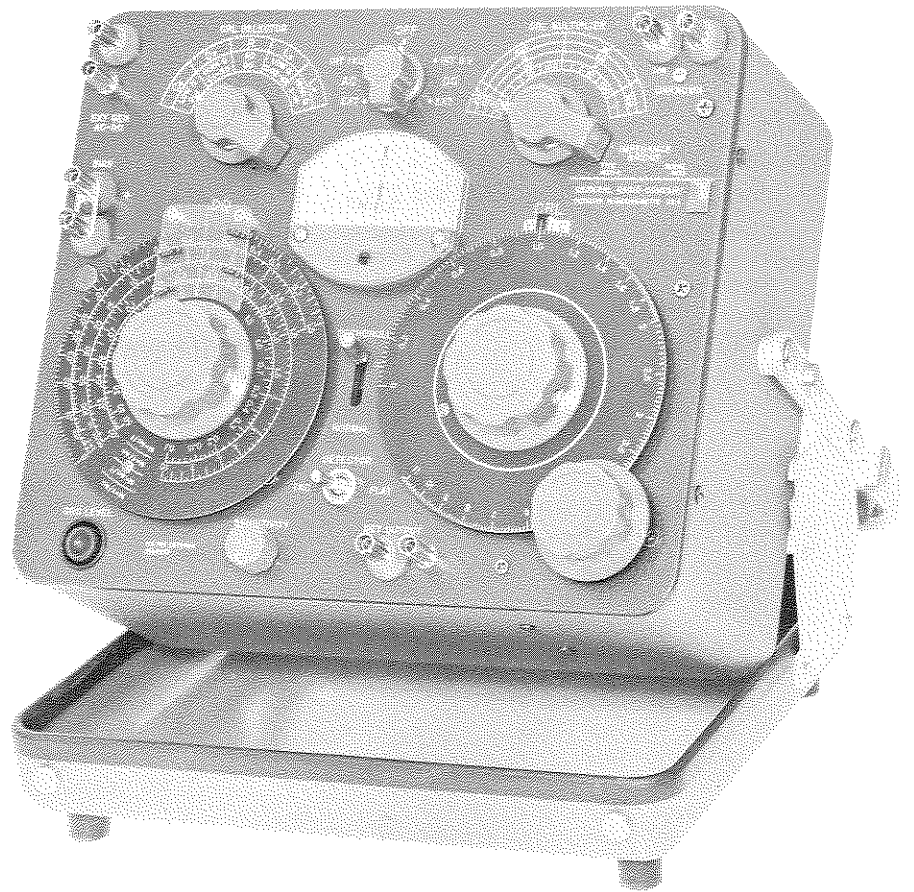

Figure 1.
Type 1650-A Impedance Bridge.



SECTION 1

INTRODUCTION

1.1 DESCRIPTION.

1.1.1 GENERAL. The Type 1650-A Impedance Bridge (Figure 1) is a self-contained impedance-measuring system, which includes five bridges for the measurement of capacitance, resistance, and inductance, as well as the generators and detectors necessary for dc and 1-kc ac measurements. Features of this bridge include one-percent C, R, and L accuracy over all ranges, high D and Q accuracy, a mechanism to facilitate low Q measurement, vis-

ual ac and dc null indications, complete portability, and a convenient tilting mechanism and carrying case.

1.1.2 CONTROLS. The Table of Controls given below lists the controls located on the front panel of the Type 1650-A Impedance Bridge.

1.1.3 CONNECTORS. The Table of Connectors given below lists the connectors located on the front panel of the Type 1650-A Impedance Bridge.

TABLE OF CONTROLS

Name	No.	Type	Function
CRL MULTIPLIER	S1	8-position selector switch	Selects impedance range.
CRL SELECTOR	S2	5-position selector switch	Selects bridge circuit.
Function Switch	S3	5-position selector switch	Turns bridge on, to type of operation required.
CRL Dial	R1	Continuous rotary control	Adjusts for bridge balance.
DQ Dial	R2	Continuous rotary control	Adjusts for bridge balance.
ORTHONULL [®] Lever		Mechanical lever	Engages Orthonull mechanism.
DETECTOR Switch	S4	Toggle switch	Controls detector response.
OSC LEVEL	R18	Thumbset rotary control	Controls ac oscillator level.
SENSITIVITY	R15 R16	Continuous rotary control	Controls ac and dc detector sensitivity.

TABLE OF CONNECTORS

Name	No.	Type	Function
UNKNOWN	J7, J8	Jack-top binding-post pair	Connects unknown impedance
EXT GEN	J1, J2	Jack-top binding-post pair	Connects ac or dc external source
BIAS	J3, J4	Jack-top binding-post pair	Connects dc bias
DET OUTPUT	J5, J6	Jack-top binding-post pair	Connects external amplifier or phones



1.2 SYMBOLS, ABBREVIATIONS, AND DEFINITIONS.

The following symbols, abbreviations, and definitions are used on the panel of the Type 1650-A and this instruction manual:

- C capacitance (—|—|—)
- C_s series capacitance
- C_p parallel capacitance
- L inductance (—|—|—)
- L_s series inductance
- L_p parallel inductance
- R resistance (—|—), the real part of an impedance
- R_s series resistance
- R_p parallel resistance
- X reactance, the imaginary part of an impedance
- Z impedance
- Q quality factor = $\frac{X}{R} = \frac{1}{D}$
for inductors $\frac{\omega L_s}{R_s} = \frac{R_p}{\omega L_p}$
- D dissipation factor = $\frac{R}{X} = \frac{1}{Q}$
for capacitors $\omega C_s R_s = \frac{1}{\omega C_p R_p}$
- PF power factor = $\frac{R}{|Z|} = \frac{R}{\sqrt{R^2 + X^2}}$
- f frequency
- ω angular frequency 2πf
- Ω ohm, a unit of resistance, reactance, or impedance
- kΩ kilohm 1 kΩ = 1000 ohms
- M multiplying factor applied to D and Q at frequencies other than 1 kc
- MΩ megohm 1 MΩ = 1 x 10⁶ ohms
- μf microfarad, a unit of capacitance
- μμf (or pf) micromicrofarad (or picofarad)
1 μμf = 1 pf = 1 x 10⁻⁶ μf
- mμf (or nf) millimicrofarad (or nanofarad)
1 mμf = 1 nf = 0.001 μf
- mΩ milliohm 1 mΩ = 0.001 ohm
- nf (or mμf) nanofarad (or millimicrofarad)
1 nf = 1 mμf = 0.001 μf
- pf (or μμf) picofarad (or micromicrofarad)
1 pf = 1 μμf = 1 x 10⁻⁶ μf
- h henry, a unit of inductance
- mh millihenry 1 mh = 0.001 h
- μh microhenry 1 μh = 1 x 10⁻⁶ h

1.3 SERIES AND PARALLEL COMPONENTS. An impedance that is neither a pure reactance or a

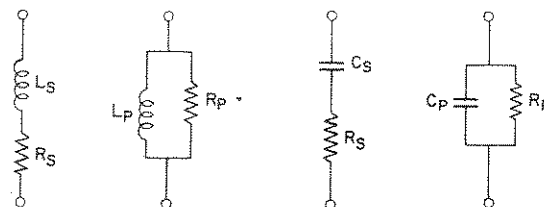

Figure 2. Equivalent Circuits for Complex Impedance.

pure resistance may be represented at any specific frequency by either a series or a parallel combination of resistance and reactance. The values of resistance and reactance used in the equivalent circuit depend on whether a series or a parallel combination is used. The equivalent circuits are shown in Figure 2. A nomograph for series-parallel conversion is given in Appendix A.

The relationships between the circuit elements are:

Resistance and Inductance

$$Z = R_s + j\omega L_s = \frac{j\omega L_p R_p}{R_p + j\omega L_p} = \frac{R_p + jQ^2\omega L_p}{1 + Q^2}$$

$$Q = \frac{1}{D} = \frac{\omega L_s}{R_s} = \frac{R_p}{\omega L_p}$$

$$L_s = \frac{Q^2}{1 + Q^2} L_p = \frac{1}{1 + D^2} L_p$$

$$L_p = \frac{1 + Q^2}{Q^2} L_s = (1 + D^2) L_s$$

$$R_s = \frac{1}{1 + Q^2} R_p; R_p = (1 + Q^2) R_s$$

$$R_s = \frac{\omega L_s}{Q}; R_p = Q\omega L_p$$

Resistance and Capacitance

$$Z = R_s + \frac{1}{j\omega C_s} = \frac{\frac{R_p}{j\omega C_p}}{R_p + \frac{1}{j\omega C_p}} = \frac{D^2 R_p + \frac{1}{j\omega C_p}}{1 + D^2}$$

$$D = \frac{1}{Q} = \omega R_s C_s = \frac{1}{\omega R_p C_p}$$

$$C_s = (1 + D^2) C_p; C_p = \frac{1}{1 + D^2} C_s$$

$$R_s = \frac{D^2}{1 + D^2} R_p; R_p = \frac{1 + D^2}{D^2} R_s$$

$$R_s = \frac{D}{\omega C_s}; R_p = \frac{1}{\omega C_p D}$$

SECTION 2

PRINCIPLES OF OPERATION

2.1 GENERAL. Figure 3 shows the five bridge circuits used in the Type 1650-A Impedance Bridge, as well as the balance equations. Hays and Maxwell inductance bridges and series and parallel capacitance comparison bridges are used to provide wide coverage over the D and Q ranges, as shown in Figure 4. Full use of these wide ranges at low Q and high D values is achieved by means of an Orthonull® balancing mechanism (refer to paragraph 2.5). Both

ac and dc measurements may be made with the bridge, which has no internal phase balance.

The variable bridge components are General Radio precision wire-wound rheostats. The CRL rheostat uses a mechanical justifying mechanism for high accuracy, and the DQ rheostat has a 54-db logarithmic range. The standard capacitor is a General Radio Type 505 silvered-mica capacitor,

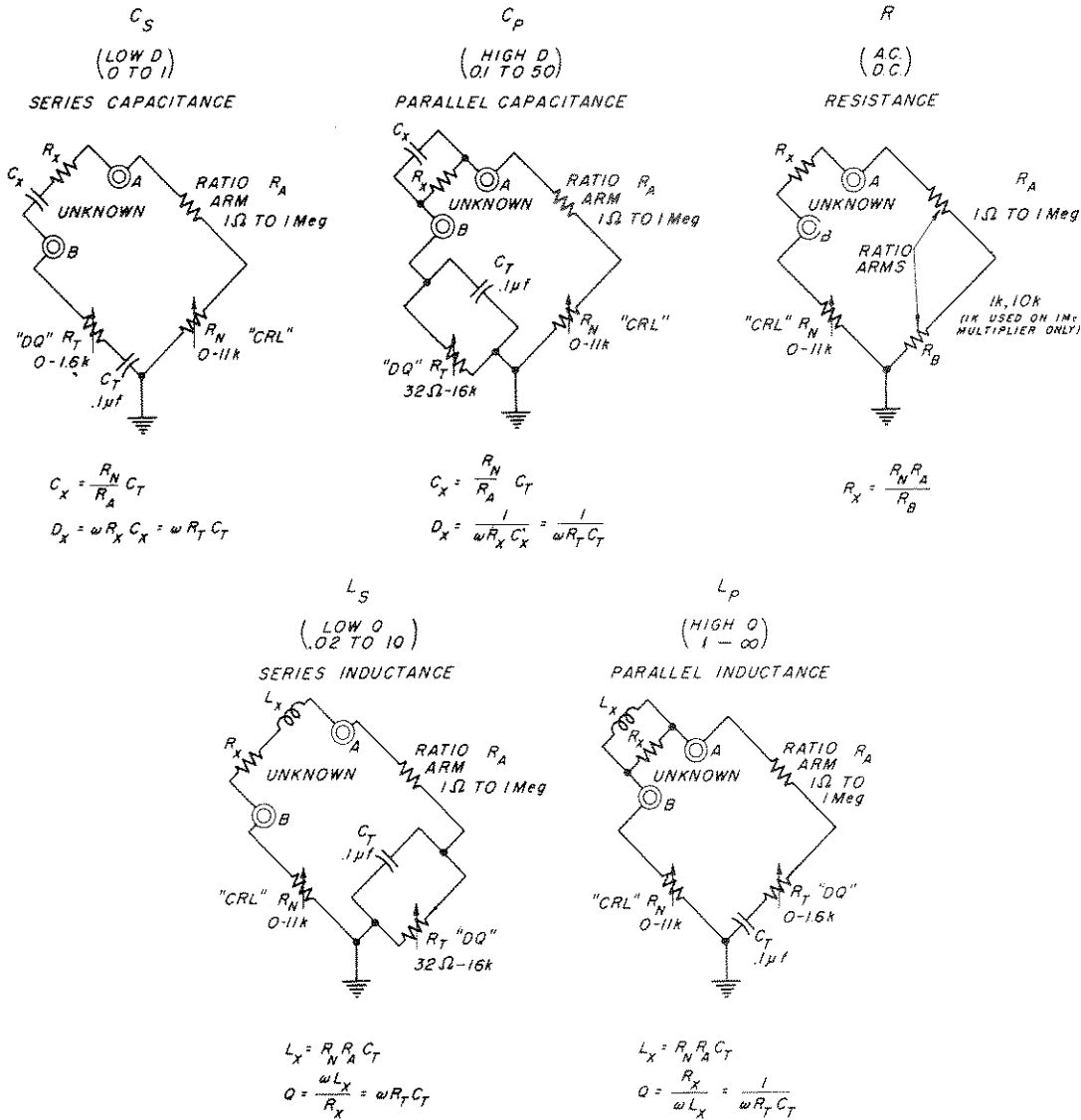

Figure 3. Bridge Circuits Used in Impedance Bridge.

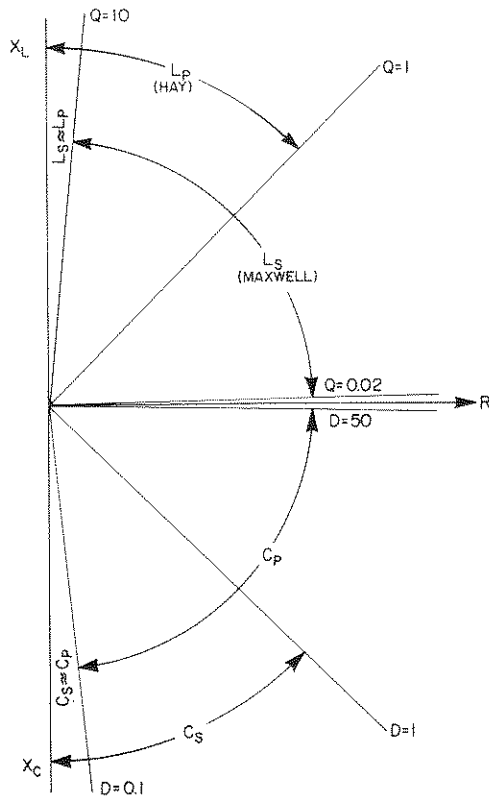

Figure 4. DQ Coverage Chart.

and the resistors are General Radio wire-wound cards except for the 1-megohm ratio arm, which uses a 1/4% precision film resistor.

2.2 BRIDGE SWITCHING. The CRL MULTIPLIER switch (S1) selects the bridge range by switching in various ratio-arm resistors. Clockwise rotation of this two-rotor switch increases the multiplier value for the R, L, and C bridges. Both ends of the range resistor are switched out so that the unused resistors may be grounded to reduce capacitance across this arm. Double, solid silver contacts insure low switch resistance and long switch life.

The CRL SELECTOR switch (S2) switches the bridge circuits. The actions of this switch are such that it (1) selects the correct rotors of S1 and grounds one of the unused rotors, (2) selects the correct standard arm, and (3) reverses the bottom two arms of the bridge to form the L and R or C bridges.

The function switch (see Figure 5) sets up the correct internal source and detector circuits for the desired operation. When this switch is in either of the two EXT positions, the EXT GEN terminals, used for externally applied ac or dc, are connected in as the bridge source.

2.3 COMPENSATION TECHNIQUES. To achieve the required D-Q accuracy over such wide ranges,

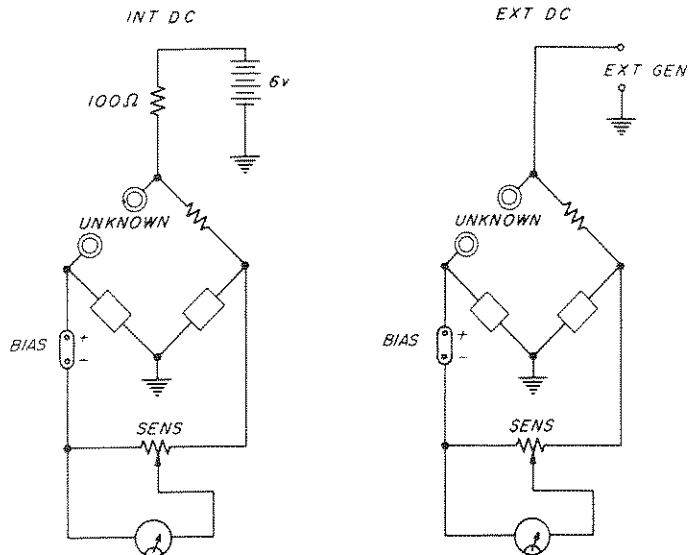
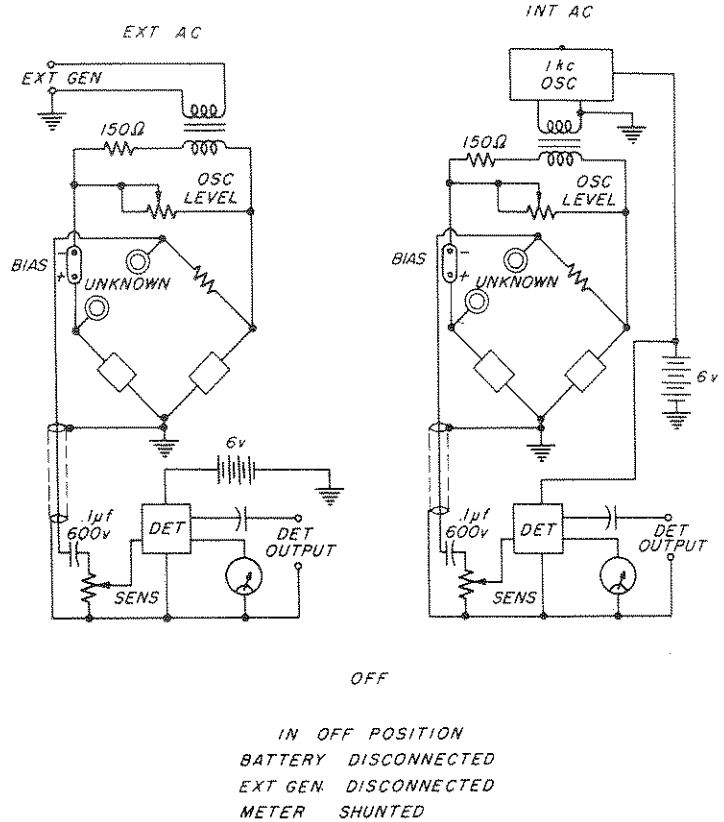

Figure 5. Source and Detector Diagrams.

several compensating schemes are used. The components used for this purpose are listed below, with brief description of their functions. Component designations refer to Figure 22.

C2 and L1: These components are used to make the standard resistance arm (R_p , Figure 3) appear resistive over a wide frequency range. This arm is shunted with considerable stray capacitance, which, without compensation, would cause a poor ac null

and an error. The resistances of L1 and R4 add up to the required 10 kilohms.

C3: This capacitor corrects the phase angle of the first section of the DQ potentiometer (R_t) to compensate for the inductance of the winding. Without compensation, this inductance would cause an error in C_s and L_p at high frequencies, and in C_p and L_s when the unknown has a very low Q or high D.

C4: This capacitor corrects for the phase shift caused by stray capacitance across the CRL rheostat (R_n). This capacitor forms a three-terminal T network with the two parts of the rheostat to produce an effective inductance to balance out the stray capacitance.

C5: This capacitor compensates for the stray capacitance across the 1-megohm ratio arm (R12 and R13). The three-terminal T network formed by these components produces an effective inductance to balance out the stray capacitance.

C6: This capacitor compensates for the inductance of the 1-ohm ratio arm (R5).

2.4 BRIDGE SOURCES AND DETECTORS. The dc bridge supply is taken from the four internal D cells, which supply about 6 volts limited by a 100-ohm resistor to a maximum of 60 ma. The dc indicator on the panel has a sensitivity of $2\mu\text{a}/\text{mm}$ near zero, a resistance of 75 ohms, and a shaped characteristic (Marion Type C null indicator).

The ac source is a 1-kc transistor LC oscillator, which uses the primary of the bridge transformer as the inductor in the tuned circuit. The output voltage is about 1 volt at the secondary of the 4-to-1 step-down transformer. This secondary is wound with resistance wire to increase the resistance to about 150 ohms, preventing external loads from affecting the bridge frequency. The OSC LEVEL control adjusts output voltage by loading the transformer secondary.

The ac detector is a three-transistor, variable-gain amplifier, which uses a twin-T RC filter to obtain selectivity with the DETECTOR switch in the 1 kc position. This amplifier drives the panel meter to provide a visual ac null indication, and the output from the amplifier is supplied to the panel DET OUTPUT terminals.

The ac oscillator and detector combined draw less than 10 ma from the internal 6-volt battery.

2.5 ORTHONULL. Orthonull is a mechanical device that improves the bridge balance convergence when low Q inductors or high D capacitors are measured.

Ordinarily, balances with such components are tedious and often impossible due to the "sliding null" resulting from the interdependence of the two adjustments. Rapid balances are possible with Orthonull, which does not affect electrical balance but which does help avoid false nulls, improving bridge accuracy for low Q measurements.

The bridge output voltage for the L_s (Maxwell) bridge can be expressed:

$$\frac{E_o}{E_{in}} = \frac{R_x + j\omega L_x - \left(\frac{R_n R_a}{R_t} + j\omega R_n C_t R_a \right)}{\text{Denominator}} \quad (1)$$

We will assume that the denominator is more or less constant in the region of the null. The numerator is the difference between the unknown impedance $R_x + j\omega L_x$ and what can be called the "bridge impedance". The bridge output is proportional to this difference, which is the distance between them on the complex plane. To balance the bridge, the "bridge impedance" is varied by adjustment of R_n (the CRL dial) and R_t (the DQ dial) until it equals the unknown impedance. An adjustment of R_t varies only the real part of the bridge impedance, whereas an adjustment of R_n varies both parts, and is therefore a multiplier of the bridge impedance. Thus, adjustment of R_t moves the bridge impedance horizontally on the complex plane, while adjustment of R_n moves it radially (see Figure 6). Each control is adjusted for a minimum voltage.

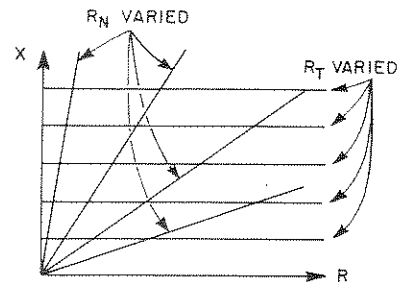

Figure 6. Loci of R_n and R_t Adjustments on Z Plane.

When $X \gg R$ (i.e. when Q is high) these two adjustments are almost orthogonal, and rapid convergence is possible. When Q is low, however, the adjustment becomes more parallel and convergence is slow, causing a "sliding null", as shown in Figure 7, where $Q = 1/2$. With smaller Q's, convergence is even slower.

The Orthonull device makes the two adjustments orthogonal by nonreciprocally ganging R_n and R_t . From equation (1) it is apparent that if R_n/R_t remained constant as R_n was varied, only the imaginary part of the bridge impedance would

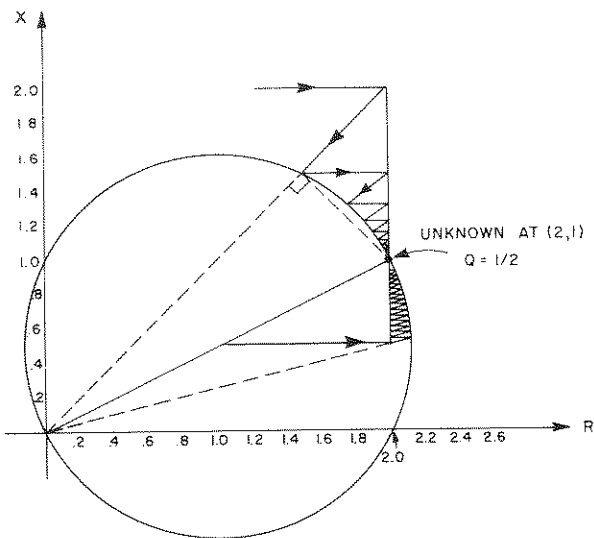

Figure 7. Loci of "Sliding Null" Balance.

change. But when R_t is adjusted, R_n must not move to vary only the real part. The solution is a simple friction clutch to permit nonreciprocal action. Both the inherent difference in friction of the two rheostats and the pulley ratio favor torque transmission in the desired direction.

The ratio R_n/R_t must be constant for variation in R_n for any initial settings of R_n and R_t , since R_t may be moved independently of R_n . This requires rheostats with exponential characteristics (and logarithmic dials). The DQ rheostat is a 54-db exponential potentiometer with the correct initial resistance (R3) added when the L_S and C_P bridges are used. The CRL rheostat is exponential in the dial range from 1 to 11, and linear below 1. Thus, for correct Orthonull action, the CRL dial must be in the range above 1.

The Orthonull mechanism is shown in Figure 21. The clutch material is between the pulley attached to the DQ shaft and the free pulley driven by the wire belt. The clutch is disengaged by the lever on the panel so that normal operation is possible for high Q (low D) components.

The advantage of Orthonull is illustrated in Figure 8, which is a plot of the numbers of adjustments necessary for a balance. Not only does the Orthonull reduce the number of balances, but it permits 1% measurements that would otherwise be impossible below a Q of 1/3, due to the finite resolution of the DQ rheostat. This finite resolution causes the meter indication to vary in jumps when Orthonull is used at Q's below 1/3. However, by choosing the best null, 1% accuracy is possible with Q's of less than 0.2. As Q is further reduced, it is even-

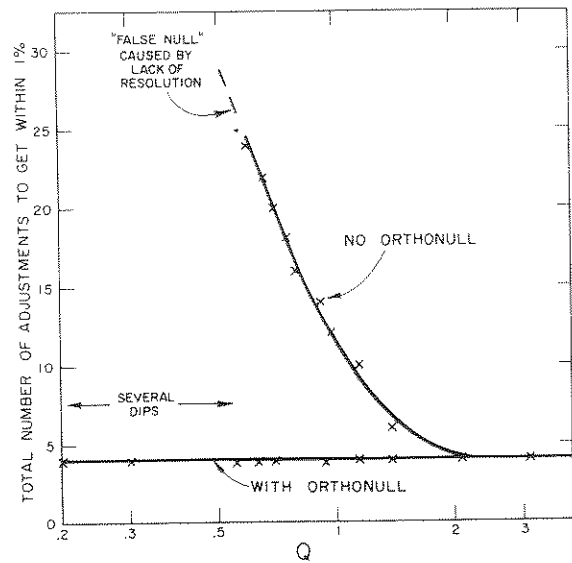

Figure 8. Number of Balances vs Q.

tually impossible to achieve 1% balances. The accuracy that can be expected with careful adjustment is plotted against Q in Figure 9. In the face of the fact that for low Q values

$$\frac{d|Z|}{|Z|} = Q^2 \frac{dL}{L}$$

the eventual lack of accuracy is justified. For example, if $Q = 0.03$, a 5% change in inductance is a change of only 45 parts per million in impedance.

As far as the user is concerned, the balancing procedure with Orthonull is essentially the same as without it. However, several suggestions for its use are given in paragraph 5.5.

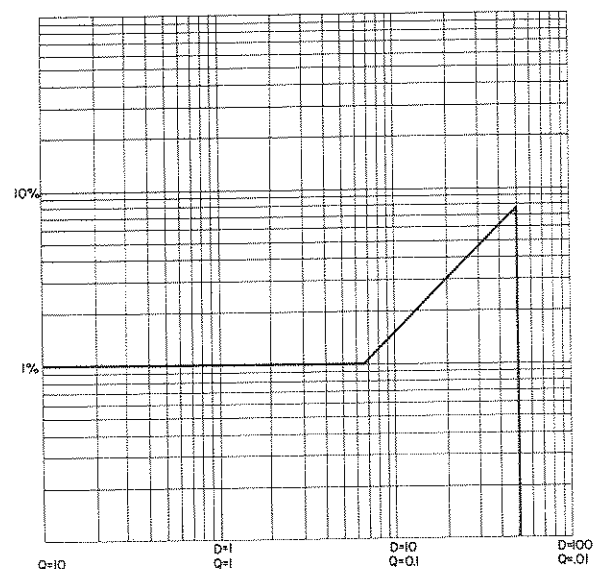

Figure 9. Accuracy vs D or Q.

SECTION 3

INSTALLATION

3.1 OPENING AND TILTING THE CABINET. The directions for opening the Type 1650-A Impedance Bridge are given on the handle support of the instrument. Once open, the instrument may be tilted to any convenient angle as shown in Figure 1. The angle should be chosen to give the most comfortable access to the knobs and the best view of the meter and dials.

The instrument may be locked fully open by the same slide pins that are used to lock the instrument closed. Thus, the instrument can be carried in the open position with the cover firmly in place.

When the instrument is open, the cover forms a convenient storage place for the instruction manual and for any other test data that should be kept with the instrument.

3.2 POWER SUPPLY. The instrument is powered by four D cells, which slide into the instrument through the cap at the top. These batteries, supplied with the instrument, should be installed with the positive terminals (center buttons) facing down.

The instrument is ready to operate as soon as it is in position and turned on.

SECTION 4

OPERATING PROCEDURE - DC MEASUREMENTS

4.1 RESISTANCE MEASUREMENTS USING 6-VOLT SUPPLY.

4.1.1 PROCEDURE.

a. Check the NULL meter mechanical zero with the function switch in the OFF position, and, if necessary, center the pointer with the mechanical zero adjustment on the meter.

b. Turn the SENSITIVITY control almost fully counterclockwise.

c. Set the CRL SELECTOR to R.

d. Connect the resistor to be measured to the UNKNOWN terminals.

e. Turn the function switch to INT 6 V.

NOTE

As the function switch is rotated from OFF to INT 6 V, it passes through an undented position where the circuit is operative but the meter is shunted to reduce sensitivity. A preliminary balance may be made with the switch in this position instead of with the SENSITIVITY control turned down.

f. Set the CRL MULTIPLIER switch and the CRL dial for a zero (center) meter reading, while adjusting the SENSITIVITY control to increase sensitivity. A meter deflection to the right indicates that the unknown is larger than the multiplier and dial setting. For greatest accuracy the final balance should be between 1 and 11 on the CRL dial (possible above 100 milliohms).

g. The value of the unknown resistance is the product of the CRL dial indication and the factor indicated on the CRL MULTIPLIER switch.

4.1.2 SENSITIVITY. With the internal 6-volt supply, one-percent balances may be easily made up to 10 kilohms and with care up to 100 kilohms. Above 100 kilohms a higher external voltage should be used (refer to paragraph 4.2). Below 1Ω, the sensitivity limits the accuracy to ±10 mΩ. A more sensitive meter may be placed in series with the internal meter by placing it across the BIAS terminals.

A 100-ohm resistor in series with the internal 6-volt supply limits the current in the unknown to 60 ma. The unknown is in series with the CRL rheostat, so that the unknown current is greatest when the CRL dial is at zero.

The maximum power that can be applied to the bridge by the internal supply is 0.09 watt; thus



there is no danger of injuring components rated at 1/10 watt or more.

At range extremes it is often desirable to make 1-kc ac measurements to increase sensitivity. For most resistors, the difference between the measured 1-kc and dc values is negligible.

4.1.3 ACCURACY OF DC RESISTANCE MEASUREMENTS. The accuracy of dc resistance measurements is $\pm 1\%$ if the CRL dial reading is between 1 and 11 as long as there is enough sensitivity. Below 1Ω , the accuracy is limited to $\pm 10\text{ m}\Omega$ by the sensitivity. Above $100\text{ k}\Omega$, an external supply is required to get 1% accuracy.

For low-resistance measurements, short, heavy leads should be used as connections to the unknown. The zero resistance of the leads should be measured with the free ends connected together, and subtracted from the bridge reading with the unknown in place. The user should be particularly careful when using banana-pin connections. For best connection to the bridge, screw the binding post hard enough to notch the wire inserted in the hole.

4.2 RESISTANCE MEASUREMENTS USING EXTERNAL DC SUPPLIES.

4.2.1 PROCEDURE. The procedure for dc resistance measurements using an external supply is the same as that described in paragraph 4.1.1 except that:

- a. The external supply should be connected across the EXT GEN terminals.
- b. Set the function switch to the DC EXT position.

WARNING

The operator should use extreme care when using external dc supplies. It is

TABLE 1
MAXIMUM DC BRIDGE VOLTAGE
AND CURRENT

Range Full Scale	Range Multiplier	E Max	I* Max
1 Ω	100 m Ω	71 v	100 ma
10 Ω	1 Ω	71 v	100 ma
100 Ω	10 Ω	71 v	71 ma
1 k Ω	100 Ω	71 v	22 ma
10 k Ω	1 k Ω	71 v	14.1 ma
100 k Ω	10 k Ω	223 v	14.1 ma
1 M Ω	100 k Ω	500 v	14.1 ma
10 M Ω	1 M Ω	500 v	14.1 ma

* It is preferable to limit current to avoid shock hazard or to reduce voltage to 10 v.

advisable to limit high-voltage supplies to a current of 5 ma or less by placing resistance in series. Care should be taken to avoid damage to the bridge and to the unknown component.

4.2.2 VOLTAGE AND CURRENT LIMITS. Bridge voltages must be limited to protect the bridge and the unknown component from damage. It is also advisable to limit the current to 5 ma or less to protect the operator from injury. The maximum voltage limit and standard EIA test voltages are described below.

Unless the utmost in sensitivity or a standard test voltage is desired, a supply of about 100 volts (e.g. a 90-volt battery), with about 25 kilohms in series, is recommended. The available power from such a supply is 0.1 watt, which is a low enough dissipation for almost all resistors, and the maximum current is 4 ma. Such a supply permits measurements up to 1 megohm with 1% accuracy. For resistances over 1 megohm, a higher voltage is desirable for good sensitivity, but it should be noted that the maximum EIA test voltage is 100 volts, and that various types of resistors have different voltage ratings.

The maximum voltage and current that may be applied to the bridge for each range are given in Table 1. Careful observation of both of these limits will prevent damage to the bridge.

Because the full voltage may be applied to the unknown, it is advisable to limit the available power to a value less than the power rating of the unknown component.

Various EIA standards for testing different types of resistors are summarized in Tables 2 and

TABLE 2
EIA STANDARD TEST VOLTAGES
(RS 172 - FIXED COMPOSITION RESISTORS)

Resistance Range	Bridge Mult Range	EIA Test Voltage Range	Bridge* Voltage
2.7 - 99 Ω	1 Ω	0.5 - 1 v	**
	10 Ω	0.5 - 1 v	50 - 71 v***
100 - 999 Ω	100 Ω	2.5 - 3 v	27.5 - 33 v
1000 - 9999 Ω	1 k Ω	8 - 10 v	16 - 20 v
10 - 99 k Ω	10 k Ω	24 - 30 v	26.4 - 33 v
100 k Ω up	100 k Ω	80 - 100 v	80 - 100 v
	1 M Ω	80 - 100 v	80 - 100 v

* at EXT GEN terminals
 ** cannot get required bridge voltage
 *** limited to 71 v by bridge

3. A suggested setup for tests at these voltages is shown in Figure 10. The voltmeter here indicates the bridge voltage, and should be set as listed in Tables 2 and 3. An alternate scheme is to put the voltmeter directly across the unknown resistor, assuming that the input resistance of the voltmeter is large enough to cause no error.

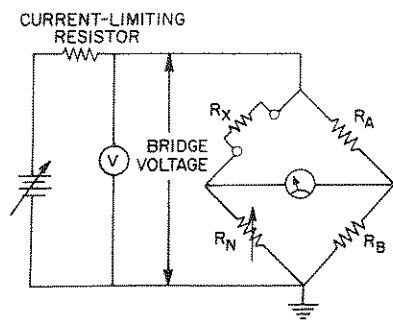

Figure 10.
Circuit for Tests
at EIA Voltages.

TABLE 3
EIA STANDARD TEST VOLTAGES
(RS 196 FIXED-FILM RESISTORS
REC 117 LOW-POWER WIRE-WOUND RESISTORS)

Resistance Range	Bridge Mult Range	EIA Max Test Voltage	Max Bridge Voltage*
less than 10 Ω	1 Ω	0.3 v	**
10 - 99 Ω	10 Ω	1 v	**
100 - 999 Ω	100 Ω	3 v	33 v
1000 - 9999 Ω	1 kΩ	10 v	20 v
10 - 99 kΩ	10 kΩ	30 v	33 v
100 kΩ up	100 kΩ	100 v	101 v
	1 MΩ	100 v	100 v

REC 117 applies only up to 9999 Ω.
* At EXT GEN terminals.
** Maximum allowance bridge voltage will not give maximum test voltage.

SECTION 5

OPERATING PROCEDURE—1-KC MEASUREMENTS

5.1 CAPACITANCE MEASUREMENT.

5.1.1 PROCEDURE.

- a. Set OSC LEVEL control fully on (clockwise).
- b. Set DETECTOR switch to 1 kc.
- c. Set CRL Selector to
 - C_s - if series capacitance is desired and D is less than 1.
 - C_p - if parallel capacitance is desired and D is between 0.1 and 50.

(Note: $C_s = C_p$ within 1% if $D < 0.1$.)

- d. Set the function switch to INT 1 KC.

e. Connect the unknown capacitor to the UNKNOWN terminals.

f. If the proper range setting of the CRL MULTIPLIER is not known, set the CRL dial at about midscale, adjust the SENSITIVITY control to give an upscale meter reading, and set the CRL MULTIPLIER switch for a minimum deflection.

g. Adjust the CRL and DQ controls for the best minimum meter reading. The SENSITIVITY control may have to be adjusted to give greater sensitivity as balance is approached.

h. The capacitance of the unknown equals the product of the CRL dial reading and the CRL MULTIPLIER switch setting. The D of the unknown is that indicated on the appropriate scale on the DQ dial.

If the D of the unknown is near or greater than 1, the Orthonull balancing mechanism is useful. Refer to paragraph 5.5.

Refer to paragraphs 7.4 and 7.6 for measurements on shielded and grounded capacitors.

5.1.2 ACCURACY. The accuracy of the C reading is $\pm 1\%$ if the balance is made between 1 and 11 on the CRL dial. Below 1 on the dial the accuracy is $\pm 1/2$ division. Thus the over-all accuracy possible is $\pm 1\%$ or ± 1 pf, whichever is greater, since 1 pf is $1/2$ a dial division on the lowest range. The D accuracy is $\pm 5\%$ or ± 0.001 , whichever is greater.

The residual ("zero") capacitance of the bridge terminals is approximately $1/2$ pf, which is less

balance to 1%, precision is impossible, so that this error is negligible. Refer to paragraph 2.5 and Figure 9.

Errors for inductance measurements at other frequencies are discussed in paragraphs 6.5 and 6.6.

5.3 AC RESISTANCE MEASUREMENT.

5.3.1 PROCEDURE.

- a. Set the OSC LEVEL control fully on (clock-wise).
- b. Set the DETECTOR switch to 1 kc.
- c. Set the CRL SELECTOR to R.
- d. Set the function switch to INT 1 KC.
- e. Connect the unknown resistor.
- f. If the proper range setting of the CRL MULTIPLIER is not known, set the CRL dial at about midscale, set the SENSITIVITY control to give an upscale meter reading, and set the CRL MULTIPLIER switch for a minimum deflection.
- g. Adjust the CRL control for the best minimum meter reading. The SENSITIVITY control may require adjustment to give greater sensitivity as balance is approached.
- h. The resistance of the unknown equals the product of the CRL dial reading and CRL MULTIPLIER switch setting.

5.3.2 ACCURACY OF AC RESISTANCE MEASUREMENTS. The accuracy of the R reading is ±1% if the balance is made between 1 and 11 on the CRL dial. Below 1 on the dial the accuracy is ±1/2 a division. Thus the over-all accuracy is ±1% or ±1 milliohm, whichever is greater, as long as the 1-milliohm residual resistance is subtracted from the R reading.

The residual resistance of 1 milliohm is that of the binding posts themselves. For low-resistance measurements, short, heavy leads should be used as connections to the unknown. The zero resistance of the leads should be measured with the free ends connected together, and subtracted from the bridge reading with the unknown in place. The user should be particularly careful when using banana-pin connections. For best connection to the bridge, screw the binding post hard enough to notch the wire inserted in the hole.

Since there is no internal Q adjustment on the R bridge, reactance affects only the ability to get a good sharp null. If the reactance is large enough to

prevent a satisfactory balance, an external capacitor may be used to make a reactance balance (refer to paragraph 7.4).

5.4 NOTES ON AC MEASUREMENTS.

5.4.1 CAPACITANCE TO GROUND. The Type 1650-A Bridge generally measures "ungrounded" components, since neither UNKNOWN terminal is connected directly to the panel. The panel should be connected to a good ground, especially if high-impedance components are to be measured. If the panel is not grounded, stray capacitances from the UNKNOWN terminals and panel to ground can produce an effective capacitance across the UNKNOWN terminals. With the panel grounded, capacitances from the UNKNOWN terminals to ground have a much less serious effect. (For measurements of grounded components refer to paragraph 7.8.)

The effects of stray capacitances to the panel (ground) are usually negligible in the capacitance bridges (see Figure 11). Capacitance from the LOW terminal to ground (C_a) shunts the detector and causes no error. Capacitance from the other terminal to ground (C_b) shunts the standard capacitor (C_t) and produces an error of

$$-\frac{C_b}{C_t} \times 100\% = -\frac{C_b}{0.1 \mu f} \times 100\%$$

Since C_t is large, it takes 1000 pf to produce a 1% error (when D is small).

In the inductance bridge (see Figure 12) C_a is across the detector and has no effect, but C_b shunts the CRL rheostat. Capacitance across this rheostat

Figure 11. Capacitance to Ground for Capacitance Measurement.

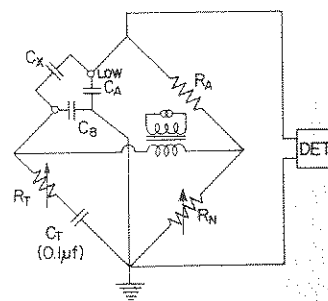
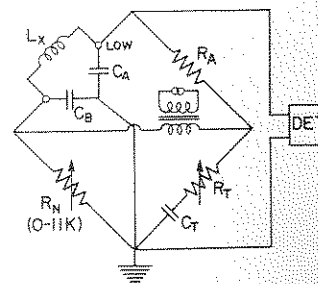

Figure 12. Capacitance to Ground for Inductance Measurement.





than the accuracy of the bridge, and therefore, negligible. If external leads are used to connect the unknown, this zero capacitance is increased and should be subtracted from the bridge reading.

The residual resistance of the bridge is 1 milliohm, which theoretically causes a D error of 0.006 when $C_x = 1000 \mu\text{f}$. In practice, capacitors of this size have such large D values that such an error is negligible. However, if leads are used to connect large capacitors this D error may become important and a correction should be made. The D error is $+\omega R_0 C_x$ (where R_0 is the lead resistance), and this amount should be subtracted from the D reading.

The residual inductance causes negligible error at 1 kc even if $C_x = 1000 \mu\text{f}$. However, connecting leads could have enough inductance to cause a C error when large capacitors are measured. The error is $+\omega L_0 C_x$ (when L_0 is the lead inductance) and this amount should be subtracted from the C reading.

The capacitance accuracy is reduced on the C_p bridge when D becomes larger than 10. However, even with the Orthonull balancing mechanism, balance to 1% precision is impossible, so that this error is negligible. Refer to paragraph 2.1, and Figure 9.

Errors for capacitance measurements at other frequencies are discussed in paragraphs 6.5 and 6.6. Table 5 (page 15) lists the corrections for residual and lead impedances.

5.2 INDUCTANCE MEASUREMENTS.

5.2.1 PROCEDURE.

a. Set the OSC LEVEL fully on (clockwise). Note: for some iron-cored inductors the inductance measured will depend upon the excitation level (refer to paragraph 5.4.4).

b. Set the DETECTOR switch to 1 Kc.

c. Set the CRL SELECTOR to

L_s - if series inductance is desired and Q is between 0.02 and 10.

L_p - if parallel inductance is desired and Q is greater than 1.

If Q is not known, use L_p . If unable to balance, switch to L_s .

(Note: $L_s = L_p$ within 1% if $Q > 10$)

d. Set the function switch to INT 1 KC.

e. Connect the inductor to be measured to the UNKNOWN terminals.

f. If the proper range setting of the CRL MULTIPLIER is not known, set the CRL dial at about midscale, set the SENSITIVITY control to give an upscale meter reading, and adjust the CRL MULTIPLIER switch for a minimum deflection.

g. Adjust the CRL control and the DQ control for the best minimum meter reading. The SENSITIVITY control may have to be adjusted to give greater sensitivity as balance is approached.

h. The inductance of the unknown inductor equals the product of the CRL dial reading and the CRL MULTIPLIER setting. The Q of the unknown is that indicated on the appropriate scale on the DQ dial.

If the Q of the unknown is near or less than 1, the Orthonull balancing mechanism is useful. Refer to paragraph 5.5.

5.2.2 ACCURACY. The accuracy of the L reading is $\pm 1\%$ if the balance is made between 1 and 11 on the CRL dial. Below 1 on the dial the accuracy is $\pm 1/2$ division. Thus the over-all accuracy is $\pm 1\%$ or $\pm 1 \mu\text{h}$, whichever is greater, since $1 \mu\text{h}$ is $1/2$ dial division on the lowest range. The Q accuracy is given in terms of $D = 1/Q$ and is $\pm 5\%$ or ± 0.001 , whichever is greater.

The residual (zero) inductance is less than $0.2 \mu\text{h}$, which is less than the accuracy of the bridge and therefore negligible. If external leads are used to connect to the unknown, this zero inductance is increased and should be subtracted from the bridge reading.

The residual resistance of the bridge is 1 milliohm, which causes a small D ($1/Q$) error. This error is less than 0.001 if L_x is more than $160 \mu\text{h}$. If long leads are used to connect to the unknown, this error may become appreciable and require a correction. The D error is $+\frac{R_0}{\omega L_x}$ (the Q error is $Q^2 \frac{R_0}{\omega L_x}$) where R_0 is the total lead resistance.

The residual zero capacitance of 0.5 pf theoretically causes an error for inductors above 250 henrys. However, this small capacitance is almost always negligible compared with the capacitance of the winding of such a large inductor. If the inductor is shielded, a three-terminal measurement will reduce the effect of stray capacitance to the shield (refer to paragraph 7.6). In order to reduce the effect of the winding capacitance it is necessary to reduce the measurement frequency. The inductance error due to a shunt capacitance C_0 is $\omega^2 C_0 L_x^2$, and this amount should be subtracted from the bridge reading. (Refer to Table 5.)

The inductance accuracy is reduced slightly if Q is less than 0.1. However, even with Orthonull



causes a D (1/Q) error of $-\omega R_n C_b$. The L error is usually negligible except when Q_x is very low.

$$\left[L_{\text{meas}} = L_x \left(1 + \frac{\omega R_n C_b}{Q_x} \right) \right]$$

Thus, for inductance measurements, it is desirable to connect the terminal with the most capacitance to ground to the UNKNOWN terminal marked LOW.

5.4.2 VOLTAGE ON THE UNKNOWN. The voltage applied to the bridge is approximately 1 volt, with a source impedance of about 150 ohms. The actual voltage on the unknown may be calculated with the aid of the circuit diagram of Figure 3 and Table 4, or may be measured with a high-impedance voltmeter.

TABLE 4
RATIO ARM VALUES AND VOLTAGE RATINGS

CRL MULTIPLIER			R_a Value	R_a Max Voltage	R_b Value	R_b Max Voltage
C	R	L				
100 μ f	100 m Ω	100 μ h	1 Ω	0.71 v	10 k Ω	71 v
10 μ f	1 Ω	1 mh	10 Ω	2.2 v	10 k Ω	71 v
1 μ f	10 Ω	10 mh	100 Ω	7.1 v	10 k Ω	71 v
100 nf	100 Ω	100 mh	1 k Ω	22 v	10 k Ω	71 v
10 nf	1 k Ω	1 h	10 k Ω	71 v	10 k Ω	71 v
1 nf	10 k Ω	10 h	100 k Ω	71 v	10 k Ω	71 v
100 pf	100 k Ω	100 h	1 M Ω	500 v	10 k Ω	71 v
	1 M Ω		1 M Ω	500 v	1 k Ω	22 v

5.4.3 SENSITIVITY. The generator-bridge-detector system is sensitive enough to permit 1% balances with the meter used as a detector. If higher sensitivity is required for precise measurements of D or Q at the range extremes, headphones or an external amplifier indicator, such as the GR Type 1232-A, may be connected to the DET OUTPUT terminals.

5.4.4 EFFECT OF LEVEL ON IRON-CORED INDUCTOR MEASUREMENTS. Iron-cored inductors are nonlinear devices and the value of inductance depends on the level of the applied voltage. In order

to make measurements repeatable, the signal level should be specified. The "initial permeability" inductance, or inductance at zero level, is often used as a reference (as is done on GR Type 1481 Standard Inductors). To obtain this value, plot L vs voltage applied and extrapolate to zero voltage. The OSC LEVEL control permits such measurements, and it is often useful to make a level change in order to see if the unknown inductance depends on the signal level.

5.5 OPERATING PROCEDURE WITH ORTHONULL. In the measurement of inductors whose Q is less than 1 or capacitors whose D is greater than 1, balancing procedure can be simplified and false nulls avoided by the use of Orthonull (refer to paragraph 2.5). The balancing procedure (essentially the same as without Orthonull once the Orthonull mechanism is engaged) is as follows:

- Set the bridge switches as described in paragraph 5.1.1, 5.2.1, or 6.1, depending on what is being measured. Connect the unknown to the UNKNOWN terminals, and connect the external generator (if one is used) as described in paragraph 6.2.
- Set the Orthonull lever to ORTHONULL.
- Set the CRL dial upscale (10 or 11).
- Make the first balance with the DQ dial.
- Adjust the CRL dial for further balance (the DQ dial, ganged to the CRL dial by the Orthonull mechanism, will follow). If the CRL setting is less than 1 at balance, turn the CRL MULTIPLIER switch to a lower range and rebalance.
- Make further balances using first the DQ dial, then the CRL dial, then the DQ dial, etc. until the meter reading cannot be reduced further.

When the Q is very low, the meter deflection will give several sharp dips as the CRL dial is rotated. To find the best dip, rotate the CRL dial slowly over a wide range without making another DQ adjustment.

Often the Q is higher at some other frequency, and it is desirable to change the frequency of measurement. This is necessary if the inductor is above resonance and appears capacitive.

SECTION 6

OPERATING PROCEDURE WITH EXTERNAL AC GENERATOR

6.1 PROCEDURE. The procedure for making measurements with an external oscillator is the same as that with the internal 1-kc oscillator except for the following:

- a. Connect the external oscillator to the instrument as described in paragraph 6.2. (Note that the OSC LEVEL adjustment controls the level of external ac applied to the EXT GEN terminals.)
- b. Set the DETECTOR switch to FLAT (if frequency is not 1 kc).
- c. Set the function switch to AC EXT.
- d. Multiply the D and Q readings by the factor M, which is given on each scale of the DQ dial.
 for low D and low Q $M = f/1 \text{ kc}$
 for high D and high Q $M = 1 \text{ kc}/f$

e. The accuracy of the bridge is within 1% if the value of D or Q lies within the limits of paragraph 6.4, and if the effects of the bridge residual impedance and of lead impedances are taken into account (refer to paragraph 6.5). The accuracy is 1% up to 20 kc for the C and L bridges and up to 5 kc for the resistance bridge.

If the presence of a nonlinear unknown causes appreciable distortion in the detector, the best null may not give the correct value. Earphones are helpful in distinguishing a null at the fundamental frequency, or an external selective amplifier, such as the Type 1232-A Null Detector, can be used.

6.2 CONNECTION OF EXTERNAL GENERATOR. The external generator may be connected to the bridge by any one of several methods. The choice depends on frequency and on the amount of overvoltage to be supplied.

The simplest method is to connect the generator to the EXT GEN terminals, which are connected to the primary of the bridge transformer when the

function switch is set at AC EXT. Because the internal bridge transformer is used in this method, one terminal of the oscillator is tied to ground, and capacitance across the oscillator has no effect. However, the inductance of the bridge transformer primary is low (23 mh) because it is used in the internal LC oscillator, and becomes quite a load on the external oscillator at low frequencies. A resistor may be put in series with the oscillator to avoid overloading and consequent distortion. (See Figure 13a and paragraph 6.3.)

The GR Type 1311-A Audio Oscillator is recommended for this application at frequencies of 50, 60, 100, 120, 400, 500, 1000, 2000, 5000, and 10,000 cps because its output will not be distorted by overloading and it has a matching transformer to drive low-impedance loads.

A matching transformer (see Figure 13b) will provide more power in the bridge at low frequencies. This need not be a shielded bridge transformer; a filament transformer (110 to 6.3 v) is useful at low frequencies.

The external generator can also be connected directly into the bridge circuit through the BIAS terminals (be sure to open the jumper strap). See Figure 13c. In this connection capacitance from either terminal of the generator to ground should be considered. Capacitance from the +BIAS terminal to the bridge chassis causes little difficulty in the capacitance bridge if it is less than 1000 pf, but causes a Q error in the inductance bridges (refer to paragraph 5.4.1). Capacitance from the negative BIAS terminal to chassis can cause a more severe error especially at high frequencies on the low impedance ranges, and should be kept to a minimum. Use of a shielded lead (Figure 13c) keeps this capacitance low.

At times, to reduce the effects of hum between oscillator and power line, it is best to ground the oscillator and to leave the bridge chassis floating.

Figure 13. Methods of Applying External AC.

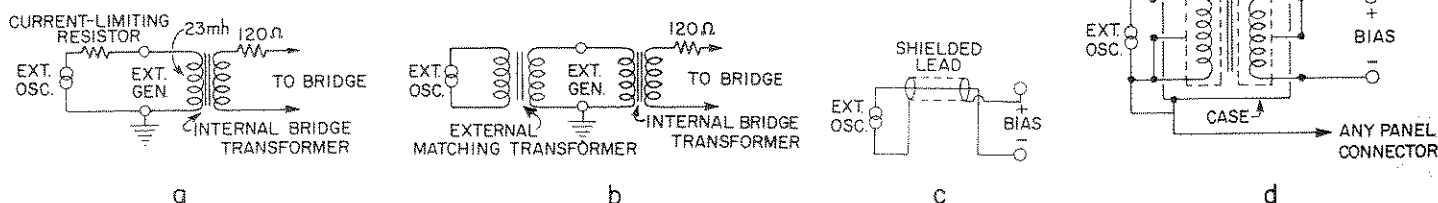



A shielded bridge transformer, such as the GR Type 578-A Shielded Transformer, may be used to make connections to the BIAS terminals to reduce capacitance difficulties. Connections are shown in Figure 13d.

6.3 MAXIMUM AC VOLTAGE. The maximum ac voltage that may be applied to the Type 1650-A Bridge depends on:

- a. the voltage and power ratings of each component (including the unknown),
- b. the bridge circuit used,
- c. the range used,
- d. the position of the variable components,
- e. the method of applying the voltage.

Exact limits for any specific measurement may be calculated from the data in Table 4 using the circuit diagrams of Figure 3. If such a maximum voltage is applied, care must be taken to avoid any adjustments of the panel controls that would result in an overload.

A much simpler approach is to limit the power into the bridge to 1/2 watt so that no bridge component can be damaged under any conditions. If the power rating of the unknown is less than 1/2 watt, the input power should be reduced accordingly.

If the external signal is applied to the EXT GEN terminals, the maximum voltage is limited to

$$E_{\max} = \left(\frac{f}{6} \right) \text{ volts rms (f in cps), or}$$

60 volts (rms) whichever is smaller

With 60 volts input the maximum power to the bridge is 1/2 watt and the open-circuit secondary voltage is 15 volts.

If the external signal is connected to the BIAS terminals, the maximum voltage is 280 volts (rms), and a series resistor of $\left(\frac{E^2}{2} - 120 \right)$ ohms (where E is in volts) should be placed in series to limit the power to 1/2 watt. Note that if E is 15 volts or less no resistor is required, since the resistance of the transformer secondary limits the power to the bridge.

6.4 ALLOWABLE D AND Q RANGES VS FREQUENCY. The D and Q readings and ranges are functions of frequency. Also, in order to avoid errors in the C and L readings, the D or Q of the unknown is further limited. The resulting allowable D and Q ranges are given in terms of frequency and D or Q of the unknown at the measurement frequency in Figure 14.

The numbers on the various limits refer to the explanations below:

1. End of DQ rheostat range.

2. First division on Low D (0.001) and High Q (1000) scales (no C or L error).

3. Limited by D of standard capacitor (no C or L error).

4. 20-cps limit because of meter response.

5. 20 kc, a nominal limit (range narrow above 20 kc).

6. C or L error due to capacitance across standard C_t and R_t .

7. C or L error due to inductance in DQ potentiometer and phase of CRL potentiometer.

8. End of the low D and high Q scales. Use the low Q scale to extend the low D range, and the high D scale to extend the high Q range.

9. Limit of 1% C and L accuracy, even with Orthonull (refer to paragraph 2.5).

10. C and L error may be 2% above this line owing to inductance in the DQ potentiometer.

Note that in the overlap area either the C_s or the C_p bridge may be used. Below 100 cps is an area not covered by either bridge, requiring an external adjustment (refer to paragraph 6.6).

6.5 CORRECTIONS FOR RESIDUAL AND LEAD IMPEDANCES. At high frequencies, the errors resulting from the residual bridge impedances and from the connecting lead impedances become more important, often requiring corrections. The formulas for the correction terms are given in Table 5. These correction terms are first-order terms only.

6.6 EXTENDING THE D AND Q RANGES AT LOW FREQUENCIES. The wide overlap of ranges (see Figure 14) permits D and Q coverage down to 100 cps without external adjustment. Below 1 kc, more of the low D and high Q range may be used than is calibrated. In this region, the low Q scale may be used to indicate D directly and the high D scale used to indicate Q directly with a maximum additional error of 2%.

Below 100 cps there is a D and Q range not covered by the internal DQ adjustment. An external rheostat or decade box may be used to extend the range of any of the D or Q scales. (However, to avoid error, the low D and high Q ranges should not be extended beyond a value of 1 at frequency of measurement (see Figure 14).

To connect the external resistance, remove the bridge from its cabinet and connect the two wires from the external resistance to the terminals marked 16 and 17, which are on the bracket directly behind the BIAS terminals (see Figure 21). Remove the jumper between terminals 16 and 17, and bring the leads out through the panel hole directly below the BIAS terminals after removing the snap button.

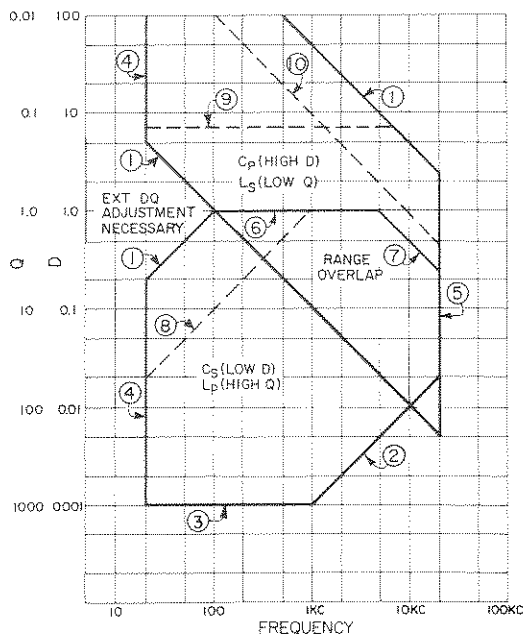

Figure 14. DQ Ranges vs Frequency. (Refer to paragraph 6.4.)

The low D and low Q scales are directly proportional to frequency. Therefore, the total D or Q value is the sum of the dial reading plus the ωRC product due to the external resistor. That is:

$$\text{low D} = (\text{low D dial reading} + 0.628R) \times f \text{ (k}\Omega, \text{kc)}$$

$$\text{low Q} = (\text{low Q dial reading} + 0.628R) \times f \text{ (k}\Omega, \text{kc)}$$

The low Q circuit has a fixed 32-ohm resistor in series with the potentiometer, but that is included in the dial calibration.

The high D and high Q scales are inversely proportional to frequency, and the effects of the internal and external resistors are therefore not additive. The DQ rheostat should be set to a minimum (high Q = ∞ or high D = 50), and the whole adjustment will be on the external resistance and will be:

$$\text{high Q} = \frac{1.592}{fR} \quad (\text{k}\Omega, \text{kc})$$

$$\text{high D} = \frac{1.592}{f(R + 0.032)} \quad (\text{k}\Omega, \text{kc})$$

6.7 OPERATION ABOVE 20 KC. Although the specifications for the Type 1650-A certify performance up to only 20kc for ac measurements, the bridge can be used with accuracy only somewhat reduced up to 100 kc. At frequencies above 20 kc, limits other than those shown in Figure 14 restrict the accuracy attainable with the bridge. These limits can be stated as a percent error, which should be added to the basic one-percent accuracy given in the instrument

TABLE 5
ERRORS DUE TO RESIDUAL AND LEAD IMPEDANCES
CORRECTION TERMS; ADD OR SUBTRACT
FROM MEASURED VALUE AS INDICATED

Measured Quantity	Series Resistance R_0 (1 m Ω + leads)	Series Inductance L_0 (0.2 μ h + leads)	Parallel Capacitance C_0 (0.5 pf + leads)
C_s	No Error	$-\omega^2 L_0 C_x^2$	$-C_0 (1 - D_x^2)$
D	$-\omega C_x R_0$	$-\omega^2 L_0 C_x D_x$	$+ D_x \frac{C_0}{C_x} (1 + D_x^2)$
C_p	$+2 R_0 \omega D_x C_x^2$	$-\omega^2 L_0 C_x^2 (1 - D_x^2)$	$-C_0$
D	$-\omega C_x R_0 (1 + D_x^2)$	$-\omega^2 L_0 C_x D_x (1 + D_x^2)$	$+ \frac{C_0}{C_x} D_x$
R	$-R_0$		
L_s	No Error	$-L_0$	$-\omega^2 C_0 L_x (1 - \frac{1}{Q_x^2})$
Q	$+Q_x^2 \frac{R_0}{\omega L_x}$	$-\frac{L_0}{L_x} Q_x$	$+ \omega^2 C_0 L_x (Q_x + \frac{1}{Q_x^2})$
L_p	$+\frac{2R_0}{Q\omega}$	$-L_0 (1 - \frac{1}{Q^2})$	$-\omega^2 C_0 L_x^2$
Q	$+\frac{R_0}{\omega L_x} (1 + Q^2)$	$-\frac{L_0}{L_x} (Q + \frac{1}{Q})$	$+ \omega^2 C_0 L_x Q$

specifications. The added error introduced above 20 kc is always negative, and the net effect of the two errors will probably be negative. This is shown in the following table of $C_p - L_s$ accuracy at CRL dial settings between 0.4 and 4.

Frequency	Basic Bridge Accuracy*	Limits of Error Added Above 20kc	Net Accuracy Limits*
50 kc	$\pm 1\%$	+0, -1%	+1%, -2%
100 kc	$\pm 1\%$	+0, -2.5%	+1%, -3.5%

*below line 10 in Figure 14

The average of the net accuracy limits shown above is -0.5% at 50 kc, -1.25% at 100 kc. If this amount is added to the measured value, the accuracy can be stated symmetrically as $\pm 1.5\%$ at 50 kc and $\pm 2.25\%$ at 100 kc.

Points to remember in measurements above 20 kc are:

- The $C_p - L_s$ bridges are more accurate than the $C_s - L_p$ bridges.
- Accuracy is greater with the CRL dial at a low setting, say between 0.4 and 4.
- While the basic 1% bridge accuracy may be plus or minus, the error introduced above 20 kc is always minus. For greater accuracy between 50 and 100 kc, add 1% to the indicated value.
- When measuring D or Q above 20 kc, always use the $C_p - L_s$ bridges.

The above information is given merely as a guide for those wondering what accuracy they might reasonably expect at frequencies from 20 to 100 kc. Bridges are not tested at these frequencies, and thus operation above 20 kc is not included in the specifications.



SECTION 7

SPECIAL MEASUREMENTS

7.1 APPLICATION OF DC BIAS TO CAPACITORS.

7.1.1 OPERATION WITH INTERNAL OSCILLATOR. Up to 600 volts of dc bias may be applied to the unknown capacitor by any of several different methods. The simplest method can be used for measuring only series capacitance; fortunately, this is how most capacitors are specified.

WARNING

Charged capacitors form a shock hazard, and care should be taken to ensure personal safety during measurement and to be sure that the capacitors are discharged after measurement. The external dc supply should also be handled carefully.

It is advisable to limit the power that may be drawn from the external dc supply to 1/2 watt (by a resistor, fuse, or circuit breaker) in order to protect the bridge components in case the unknown is short-circuited.

The various methods of applying dc bias to capacitors are described below, along with suggestions for their use:

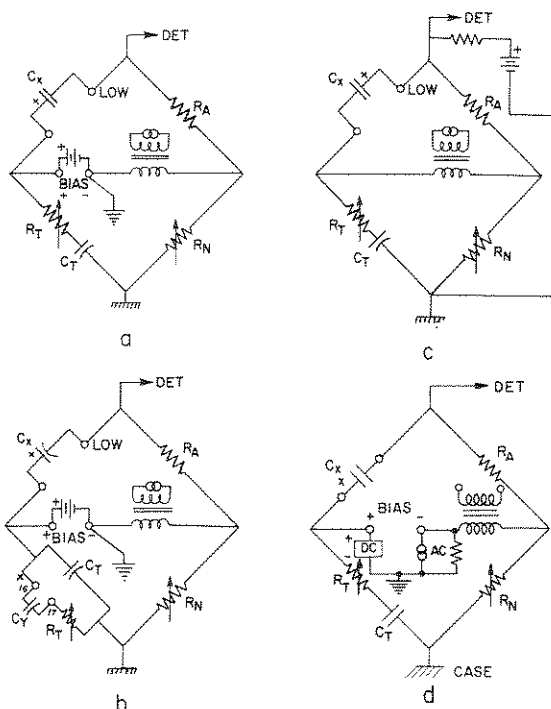

Figure 15. Methods of Applying DC Voltages to Capacitors.

Method 1. C_s Bridge (see Figure 15a).

In this method, up to 600 volts may be applied on any range. Connect the negative terminal of the unknown capacitor (if polarized) to the LOW UNKNOWN terminal. The dc supply used should have a low ac output impedance. It is usually helpful to ground the negative side of the dc supply and to leave the bridge floating to avoid hum from the power line. If the negative side of the supply (-BIAS terminal) is grounded, the bridge panel and LOW UNKNOWN terminal will be at low dc potential with low signal voltage on them.

Method 2. C_p Bridge (see Figure 15b).

The same precautions mentioned in Method 1 apply here, and a blocking capacitor should be added between the internal terminals 16 and 17, which are directly behind the BIAS terminals. The positive side of the blocking capacitor should be tied to terminal 16 as shown in Figure 15b. The voltage rating of this capacitor should be sufficient for the full dc applied. The capacitance required depends on the D of the unknown and on the accuracy required. The errors caused by this capacitor are:

$$C \text{ measured} = C_x \left(1 - \frac{C_t}{C_y} D_x^2 \right) \quad (C_t = 0.1 \mu\text{f})$$

$$D \text{ measured} = D_x \left(1 + \frac{C_t}{C_y} D^2 \right)$$

Method 3. C_s or C_p Bridge (see Figure 15c).

This method is recommended for small capacitors. The maximum voltages that may be applied to the C_s bridge are given in Table 6. For the C_p bridge, the maximum voltages on the unknown given in Table 6 apply, but the maximum voltages on the bridge are a function of the DQ dial setting.

The ac impedance of the dc source should be high (>10 k) to avoid shunting the detector, and the dc source should have low hum. The advantages of this circuit are that the bridge and supply are both grounded and the dc current can be easily limited by a resistor, since the impedance of the source should be high.

WARNING

Note that the LOW UNKNOWN terminal has the high voltage on it in this method.

TABLE 6
MAXIMUM DC VOLTAGES APPLIED TO CAPACITORS BY METHOD 3

Range Multiplier	Max Volts On Bridge	Max Volts On Unknown
100 pf	505 v	500 v
1 nf	242 v	220 v
10 nf	142 v	71 v
100 nf	78 v	7 v
1 μf	72 v	0.7 v
10 μf	71 v	0.07 v
100 μf	71 v	0.007 v

7.1.2 OPERATION WITH EXTERNAL AC GENERATOR. When both external ac and dc supplies are used, hum may be introduced by the capacitance to the line in the power transformers of these generators. The bridge should be set up as shown in Figure 15d, with both the ac and dc supplies grounded and the bridge not grounded. The ac generator should be shunted by a resistor if it does not provide a path for dc.

Method 3, Paragraph 7.1.1, may also be used to apply dc bias. The bridge and both the ac and dc supplies are grounded (Figure 15c), and the ac generator is connected to the EXT GEN terminals. This method is particularly useful for high-frequency measurements of small capacitors. (Refer to Paragraphs 6.2 and 7.1.1.)

7.2 APPLICATION OF DIRECT CURRENT TO INDUCTORS. Direct current may be supplied to inductors during measurement by any of several different methods so that incremental inductance measurements may be made. The various methods are described below along with suggestions for their use. A blocking capacitor (C_b in Figure 16) is needed only for the L_S bridge shown. This capacitor (not supplied with the bridge) should be connected by the user between terminals 16 and 17, on a bracket behind the BIAS terminals (see Figure 21). The errors caused by this capacitor are:

$$L_S \text{ measured} = L_x \left(1 - \frac{C_t}{C_b} \frac{1}{Q_x^2} \right) \quad C_t = 0.1 \mu f$$

$$Q \text{ measured} = Q_x \left(1 - \frac{C_t}{C_b} \frac{1}{Q_x^2} \right)$$

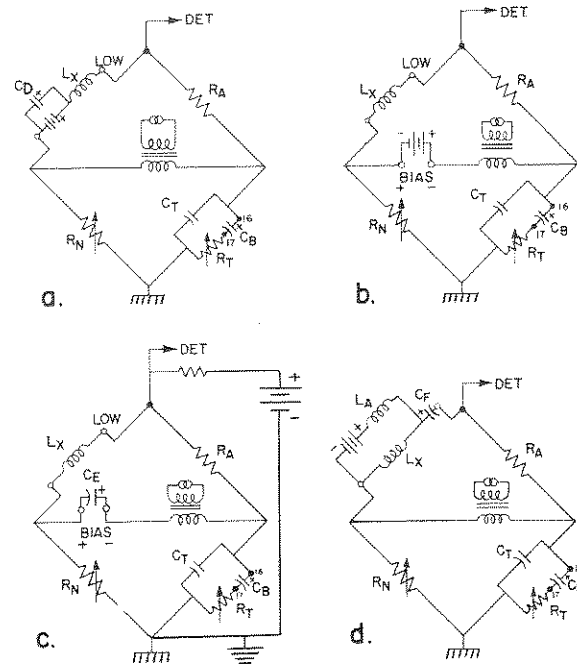

Figure 16. Methods of Applying DC to Inductors. (Blocking Capacitor C_b is not Supplied with the Bridge)

WARNING

Large inductors carrying high currents are shock hazards. Reduce the dc to zero before disconnecting the dc supply or unknown inductor.

Method 1. (See Figure 16a.)

The maximum current is limited to that given in Table 7. The dc supply may be tied to ground and the instrument left floating as shown, where the capacitance of the bridge to ground shunts R_N and causes a D (1/Q) error of $-\omega R_N C$. If the dc supply has low capacitance to ground and low internal capacitive coupling to the power line, the bridge may be grounded and the dc supply left floating.

The blocking capacitor, C_b , must be of high enough rating to take a voltage equal to the maximum direct current in amperes times 120 ohms.

The source impedance of the dc supply must be low compared with that of the unknown, since the bridge measures both of these impedances in series. A large capacitor (C_d) shunting the dc supply is sometimes useful.

Method 2. (See Figure 16b.)

The maximum current in this method is limited to that given in Table 7. The dc supply is connected to the BIAS terminals with the signs reversed in order to keep the bridge case and dc supply both



TYPE 1650-A IMPEDANCE BRIDGE

at zero volts dc from ground. The blocking capacitor C_b must be able to take the full dc voltage. The ground connection may be made to either the panel or the dc supply.

TABLE 7
MAXIMUM DC THROUGH INDUCTORS
OR RESISTORS
(METHODS 1 AND 2)

Range Multiplier		Maximum Current	R_a (Ratio Arm)
L	R		
100 μ h	100 m Ω	100 ma	1 Ω
1 mh	1 Ω	100 ma	10 Ω
10 mh	10 Ω	71 ma	100 Ω
100 mh	100 Ω	22 ma	1 k Ω
1 h	1 k Ω	7.1 ma	10 k Ω
10 h	10 k Ω	2.2 ma	100 k Ω
100 h	100 k Ω	0.5 ma	1 M Ω
	1 M Ω		1 M Ω

Method 3. (See Figure 16c.)

This method is recommended for large inductors, since the maximum current is the same for any range. In this method both the bridge and the dc supply are grounded.

The maximum allowable current for any range is 40 ma. The output impedance of the dc supply should be high enough to avoid loading the detector (a series resistor is often useful) and should have low hum.

The blocking capacitor C_e must be able to take the dc IR drop across the unknown inductor, and C_b must be able to take the whole dc voltage.

Method 4. (See Figure 16d.)

The method must be used with very large dc. The maximum voltage on the unknown is limited only by the rating of C_f . The ac source impedance of the dc supply must be much higher than the impedance of the unknown since the bridge measures the parallel combination of these two impedances. A large inductor, L_a , may be connected as shown to provide a high source impedance. Often it is possible to resonate the feed inductor to increase the source impedance further. Also, the impedance of the blocking capacitor, C_f , should be low compared with the impedance of the unknown since it is directly in series with the unknown.

7.3 DC BIAS FOR AC RESISTANCE MEASUREMENTS. A dc bias voltage and current may be applied to various types of nonlinear resistive ele-

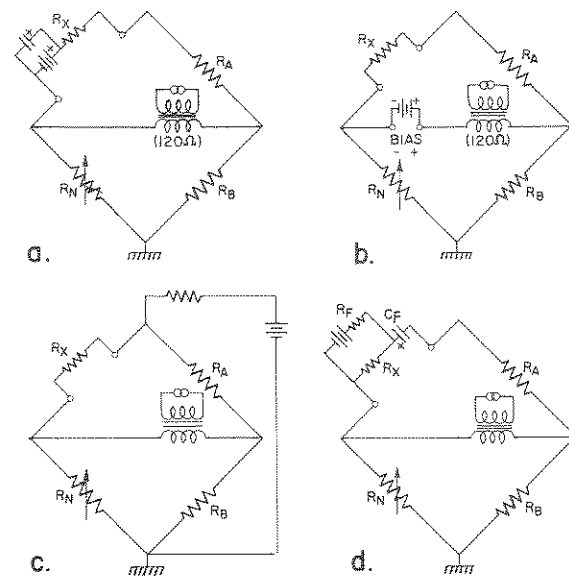

Figure 17. Methods of Applying DC for AC Resistance Measurements.

ments such as diodes, varistors, and thermistors in order to measure small ac signal resistance. For voltage-sensitive devices, diodes, and varistors, the ac resistance is the slope of the dc voltage-current curve. For thermally sensitive devices, the ac resistance is equal to the dc resistance as long as the time constant is much longer than the period of the ac signal. Several methods of applying dc are shown in Figure 17.

Method 1. (See Figure 17a.)

In this method all of the current supplied flows through the unknown. The current is limited to the amount given in Table 7. The dc source impedance should be low compared with that of the unknown, or the source should be shunted by a large capacitor as shown. If the dc supply is grounded, the bridge chassis may be at a potential of up to 6 volts.

Method 2. (See Figure 17b.)

This method removes the dc supply from the bridge arm so that its impedance is not so important. The current in the unknown is equal to the current supplied multiplied by $\frac{R_b}{R_a + R_b}$, and should be limited to that given in Table 7. The voltage applied should be limited to 71 volts*. If the dc supply is grounded, the bridge chassis may be at a potential of up to 37 volts.

Method 3. (See Figure 17c.)

This method permits grounding of both the bridge chassis and the dc supply. The current

*22 volts at 1M Ω range.

through the unknown is equal to the current supplied multiplied by $\frac{R_a}{R_a + R_x}$. The dc current and voltage limits are given in Table 1, page 8.

Method 4. (See Figure 17d.)

This method permits large currents through low resistors, since no current flows in the bridge. The resistor R_f should be large compared with the unknown, and the blocking capacitor, C_f , should be able to take the dc voltage $I_{dc}R_x$. The impedance of the blocking capacitor should be low compared with that of the unknown.

7.4 MEASUREMENT OF AC RESISTANCE WITH REACTANCE. If the unknown resistor has a large reactance, a good ac balance is difficult to obtain. Use of an external capacitor to balance the reactance will permit a sharp balance.

If the unknown is capacitive, the external capacitor should be connected from either BIAS terminal to ground, as in Figure 18a. At balance, the CRL dial will read the effective parallel resistance of the unknown, and the external capacitance C_n is a measure of the capacitance of the unknown. The formula is

$$C_x = C_n \frac{R_n}{R_x}$$

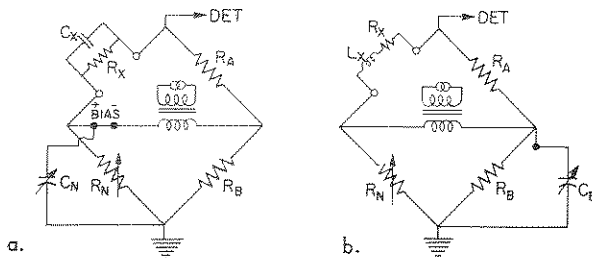

Figure 18. Measurement of Resistance with Reactance.

If the unknown is inductive the external capacitor should be connected across the standard resistance as in Figure 18b. The connection must be made internally to terminal 16 (located on a bracket behind the BIAS terminals), and the lead brought out through the panel hole. With this connection the CRL dial indicates series resistance and the external capacitor C is a measure of the Q of the resistor. The formula is

$$Q = \omega R_b C_b$$

where $R_b = 10 \text{ k}\Omega$, except on the $1 \text{ M}\Omega$ range where it is $1 \text{ k}\Omega$.

Note that $R \text{ series} = R \text{ parallel}$ within 1% as long as Q is less than 0.1. The formulas are

$$R_s = R_p \frac{1}{1 + Q^2}$$

$$R_p = R_s (1 + Q^2)$$

$$Q = \frac{\omega L_s}{R_s}$$

$$Q = \omega R_p C_p$$

The reactive balances are limited to a Q accuracy of about ± 0.01 .

7.5 RESONANT FREQUENCY OF TUNED CIRCUITS. The resonant frequency of a series or parallel tuned circuit may be found by means of an external variable-frequency oscillator and the ac resistance bridge. The external oscillator is connected as described in paragraph 6.2, and the tuned circuit is connected to the UNKNOWN terminal.

The frequency and the CRL dial are then varied for the best null attainable. The bridge indicates, at balance, the effective series resistance of a series tuned circuit or the effective parallel resistance of a parallel tuned circuit, while the oscillator indicates the resonant frequency.

7.6 MEASUREMENTS ON SHIELDED THREE-TERMINAL COMPONENTS. When the unknown is shielded and the shield is not tied to either unknown terminal a three-terminal component is formed (see Figure 19). The impedance Z of the component itself is the direct impedance of the three-terminal system. To measure the direct capacitance of a three-terminal system, connect the third terminal to the panel of the instrument, using any grounded panel terminal or a ground lug with screw just below the UNKNOWN terminals. The capacitances to the shield have negligible effect as long as one of them is reasonably small (refer to paragraph 5.4.1).

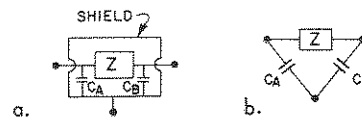

Figure 19. Shielded Three-Terminal Impedance.

Often the shield of an inductor is not connected to either terminal. When the inductance and frequency are low so that stray capacitance across the inductor causes negligible error, the shield should be connected to the UNKNOWN terminal marked LOW. When the inductance (or frequency) is high, the effective inductance is increased because of the shunting capacitance. The error is $+100 (\omega^2 L_x C_x)\%$ (refer to paragraph 5.2.2). To avoid an inductance error, the shield may be tied to the panel of the bridge.



The inductor terminal that has the larger capacitance to the shield should be tied to the LOW bridge terminal. A Q error results from the capacitance from the other UNKNOWN terminal to the shield (C_b in Figure 12) but a better measurement of L_x is possible. (This connection does not affect the winding capacitance itself.)

7.7 REMOTE MEASUREMENTS. Due to the small effect of stray capacitance to ground, particularly for capacitance measurements (refer to paragraph 5.4.1), the unknown may be placed some distance away from the bridge. If at least one of the connecting leads is shielded, the capacitance between the leads is avoided. The shielded lead should be connected to the LOW UNKNOWN terminal, and the bridge should be grounded. The other lead may also be shielded, at the cost of increased capacitance to ground. When low impedance measurements are made, the effect of the lead resistance and inductance should be considered (see Table 5).

7.8 MEASUREMENT OF GROUNDED COMPONENTS. If the component to be measured is connected directly to ground, the component may be measured with the case of the Type 1650-A floating off ground.

Either unknown terminal of an unknown capacitor may be grounded. Grounding the low terminal tolerates large capacitance from the case to ground, but increases sensitivity to hum. However, most of the hum can be removed by the internal 1-kc filter in the amplifier. Grounding the other unknown terminal decreases sensitivity to hum, but a capacitance of 1000 pf from the case to ground causes a 1% capacitance error (refer to paragraph 5.4.1).

If the unknown is an inductor, the LOW terminal should be grounded.

Even when the bridge is floating, the bridge panel can be used as a guard terminal for three-terminal or remote measurements.

7.9 USE OF THE TYPE 1650-P1 TEST JIG.

7.9.1 GENERAL. The 1650-P1 Test Jig provides a means of making quick connections to the bridge with a pair of conveniently located clip terminals. When the Type 1650-A is set up for limit measurements (refer to paragraph 7.10), the combination facilitates the rapid sorting of electrical components.

The jig is also useful for measurements on small capacitors because of its small zero capacitance and because the unknown component is positioned and shielded to make repeatable measurements possible.

7.9.2 INSTALLATION. The test jig is connected to the bridge UNKNOWN terminals by means of the shielded Type 274 Connector attached to the jig. A three-terminal connection is necessary. The third connection is made by means of the screw, located directly below the UNKNOWN terminals, and the lug on the shield of the connector. This screw makes the ground connection to the jig and also holds the connector in place.

The leads of the test jig may be brought around in back of and underneath the bridge so that the jig may be located directly in front of the bridge without interference from the leads.

7.9.3 RESIDUAL IMPEDANCES OF THE TEST JIG. The residual resistance of the leads is about 80 milliohms (total) and the inductance is about 2 μ h. The zero capacitance, when the leads are connected to the bridge, is negligible (≈ 0.2 pf). The shielded leads cause a capacitance to ground of about 100 pf each. Corrections may be necessary for the residual resistance and inductance when measurements are made on low impedances (see Table 5, page 15). The capacitances to ground cause no error for capacitance measurements, but can cause a D (1/Q) error up to about 0.007 for inductance measurements (refer to paragraph 5.4.1).

7.10 LIMIT TESTING.

The Type 1650-A may be set up to provide a go-no-go indication useful for component setting. The panel meter is used as the indicator. The set-up procedure is as follows:

- a. Balance the bridge with one of the components to be measured (preferably one within tolerance).
- b. Offset the CRL dial by the desired tolerance, if the tolerance is symmetrical, or by one half of the total allowable spread if unsymmetrical.
- c. Adjust the SENSITIVITY control for a five-division meter deflection.
- d. Set the CRL dial to the center value (the nominal value if the tolerance is symmetrical).
- e. Connect each component to the bridge (or Type 1650-P1 Test Jig). If the meter deflection is less than five divisions, the component is within limits.

When the unknown has a tolerance greater than $\pm 10\%$, the limits may be in error by more than 1% if the above method is used. A sure method is to set the CRL dial so that unknown components at both limits give the same deflection.

SECTION 8

SERVICE AND MAINTENANCE

8.1 GENERAL. The two-year warranty given with every General Radio instrument attests the quality of materials and workmanship in our products. When difficulties do occur, our service engineers will assist in any way possible.

In case of difficulties that cannot be eliminated by the use of these service instructions, please write or phone our Service Department, giving full information of the trouble and of steps taken to remedy it. Be sure to mention the serial and type numbers of the instrument.

Before returning an instrument to General Radio for service, please write to our Service Department or nearest district office (see back cover), requesting a Returned Material Tag. Use of this tag will insure proper handling and identification. For instruments not covered by the warranty, a purchase order should be forwarded to avoid unnecessary delay.

8.2 BATTERY REPLACEMENT. The Type 1650-A Impedance Bridge is powered by four D cells, which will last for over 500 hours operation with normal use. The instrument can operate with greatly reduced battery voltage, but will become less sensitive; also, the oscillator frequency may change slightly.

For a simple check of the battery, connect an ammeter from the LOW UNKNOWN terminal to any panel (ground) terminal and measure the current flowing when the function switch is in the DC INT 6 V position. If this current is less than 40 ma, the cells should be replaced.

8.3 ADJUSTMENTS. The few internal adjustments are factory set and should not require attention. Procedures for setting these components are included here, but should be used only when the operator is positive that the component in question requires re-adjustment.

C5 This capacitor is set to give a zero D reading when a 1000-pf 3-terminal air capacitor is measured on the 100 pf CRL MULTIPLIER position.

(Refer to paragraph 7.4 describing 3-terminal measurements).

R1 The light-colored screws on the rear of this rheostat the characteristic of this circuit element. They should be set so that the resistance of R1 is equal to the CRL dial reading multiplied by 1000 ohms.

8.4 TROUBLE-SHOOTING SUGGESTIONS.

8.4.1 BRIDGE PROPER.

a. Noisy or Erratic Balances. If the Type 1650-A bridge is idle for an extended period, surface contamination of the wire-wound CRL and DQ adjustments may cause an erratic behavior of the null indicator. To remedy this situation, rotate the controls back and forth several times.

b. Bridge Error. The bad component causing a bridge error can usually be determined from a knowledge of which ranges and bridges are affected. The CRL rheostat, R1, is the only component used on all ranges of all circuits.

c. Inability to Obtain Balance. If the bridge does not seem to balance at all, several things should be considered before the bridge is assumed to need repair.

- (1) Is the unknown component connected correctly?
- (2) Is the unknown what it is thought to be? (Large inductors can look like capacitors at 1 kc.)
- (3) Are all the panel switches set properly?
- (4) Is the jumper between the BIAS terminals in place?
- (5) Is the Q so low (D so high) that Orthonull should be used?

d. Low or No Meter Deflection When Bridge Unbalanced.

- (1) Is OSC LEVEL control on?
- (2) Is SENSITIVITY control on?
- (3) Are the cells correctly in place? (For battery check refer to paragraph 8.2.)

8.4.2 CHECKING ORTHONULL OPERATION. The Orthonull mechanism is working correctly if any



motion of the CRL dial causes a motion of the DQ dial, but not vice versa, when the Orthonull mechanism is engaged. When the Orthonull is disengaged, the two controls should be independent of each other. If the CRL dial does not drive the DQ dial, turn the nut on the spring spade lug clockwise to increase the tension on the spring attached to the ORTHONULL lever. Also be sure that nothing is impeding the full rotation of the DQ potentiometer. If the DQ dial drives the CRL dial, turn this nut counterclockwise.

8.4.3 OSCILLATOR AND DETECTOR CHECKS. The oscillator and detector circuits are shown in Figure 22, and test point voltages are listed in Table 8. This information should enable one skilled in the art to locate any faulty components in these circuits.

For access to the printed circuit shown in Figure 20, unfasten the DETECTOR switch and the SENSITIVITY controls from the panel, remove the three screws holding the board in place, disconnect the PHONE connector and slide the board out. If this is done, the board is still connected and operative.

8.5 CALIBRATION CHECK. The calibration of the Type 1650-A Bridge can be checked and any faulty components located with the series of 10 measurements listed in Table 9. Four standard resistors and one standard capacitor are needed for these

measurements. The following results are possible from the series of measurements:

1. When any one measurement is in error, the faulty component is listed in Table 9.
2. When both 1-megohm measurements (G and H) are in error, the series combination of R12 and R13 is out of tolerance.
3. When all resistance measurements (or all except H) are in error, R4 plus the resistance of L1 is out of tolerance.
4. When both capacitance measurements (I and J) are in error, C1 is out of tolerance.
5. When all measurements are in error, the CRL rheostat is in error.
6. When all measurements at either 1 or 10 on the CRL dial are in error, the CRL rheostat is in error at either 1 or 10.
7. When all measurements are within tolerance, all the fixed components of the bridge are within tolerance, and the CRL rheostat is correct at the 1 and 10 settings. The CRL rheostat may be incorrect between 1 and 10, however. A decade resistance box, such as the Type 1432-J Decade Resistor, can be used to check the dial indication at any point.

The DQ rheostat can be checked at any point by measurement of a resistance-capacitance combination with a known value of D. This rheostat is used for D and Q measurements with all of the C and L bridges.

TABLE 8
TRANSISTOR VOLTAGES

	Collector	Base	Emitter
TR1	0	+ 5.65	+ 5.7
TR2	+ 1.60	+ 1.05	+ 0.95
TR3	+ 1.70	1.06	+ 0.96
TR4	+ 6.0	+ 1.60	+ 1.40

Set: SENSITIVITY counterclockwise
OSCILLATOR LEVEL clockwise
INT 1 KC
A General Radio Type 1803-B Vacuum-Tube Voltmeter was used to obtain the above voltage .

TABLE 9
MEASUREMENTS FOR CALIBRATION CHECK

Measurement	Standard	General Radio Type No.	Bridge Circuit	Range Multiplier Setting	Faulty Component (Result 1)
A	1 Ω	500-A	RAC	100 mΩ	R5
B	1 Ω	500-A	RAC	1 Ω	R6
C	100 Ω	500-D	RAC	10 Ω	R7
D	100 Ω	500-D	RAC	100 Ω	R8
E	10 kΩ	500-J	RAC	1 kΩ	R10
F	10 kΩ	500-J	RAC	10 kΩ	R11
G	1 MΩ	500-X	RAC	100 kΩ	(both R14 and R12 + R13)
H	1 MΩ	500-X	RAC	1 MΩ	R14
I	0.1 μf	505-T	C _S	100 nf	(both C1 and R9)
J	0.1 μf	505-T	C _S	1 μf	R9

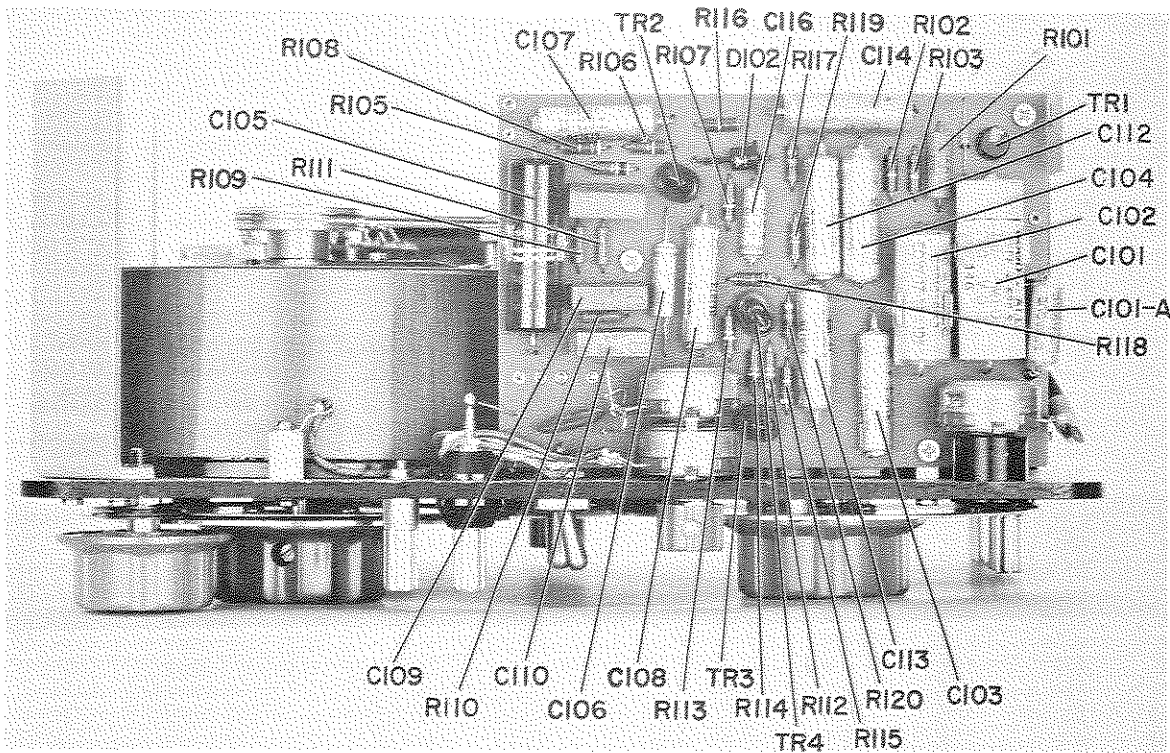

Figure 20. Bottom Interior View.

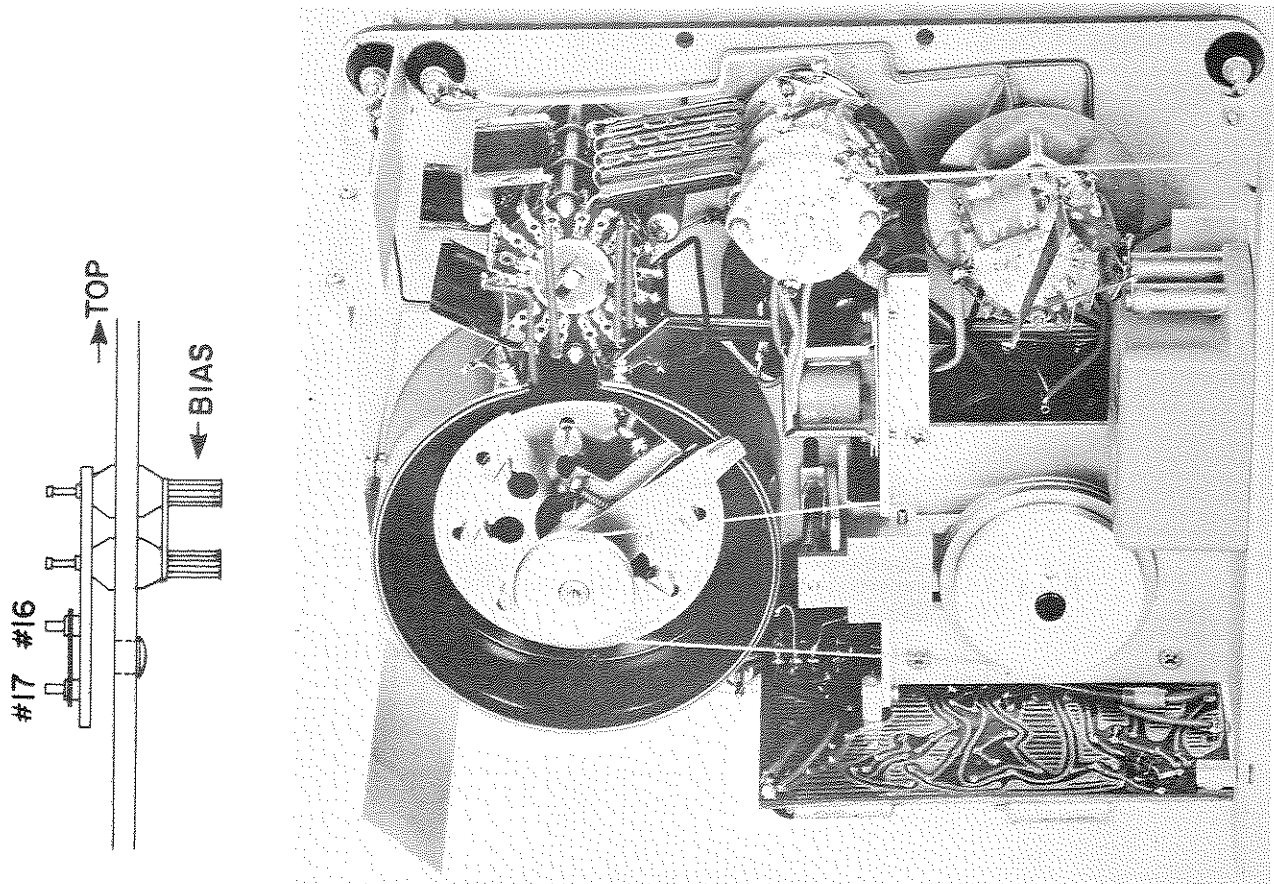

Figure 21. Rear Interior View.



TYPE 1650-A IMPEDANCE BRIDGE

PARTS LIST

RESISTORS			
R1	0-11.7 k		433-408
R2	0-16 k		977-402
R3	31.6	±1% 1/4 w	REF-65
R4	9930	±1/4%	510-390-2
R5	0.982	±1/4%	510-437
R6	9.0	±1/4%	510-437
R7	90	±1/4%	510-437
R8	900	±1/4%	510-437
R9	1 k	±1/4%	602-304
R10	10 k	±1/4%	602-305-2
R11	100 k	±1/4%	602-306
R12	30 k	±5% 1/2 w	REC-20BF
R13	970 k	±1/4% 1 w	REF-6-4
R14	1.111 k	±1/4%	510-390-2
R15	500	}	1650-400
R16	50 k		
R17	100	±5% 1/2 w	REC-20BF
R18	2.5 k	±10%	POSC-18
R19	4.7	±10% 1/2 w	REW-3C
R20	470	±5% 1/2 w	REC-20BF
R101	10	±1% 1/2 w	REF-70
R102	22	±5% 1/2 w	REC-20BF
R103	2 k	±5% 1/2 w	REC-20BF
R104	150	±5% 1/2 w	REC-20BF
R105	30 k	±5% 1/2 w	REC-20BF
R106	120 k	±5% 1/2 w	REC-20BF
R107	20 k	±5% 1/2 w	REC-20BF
R108	4.7 k	±5% 1/2 w	REC-20BF
R109	18 k	±1% 1/8 w	REF-60
R110	18 k	±1% 1/8 w	REF-60
R111	5.75 k	±1% 1/8 w	REF-60
R112	30 k	±5% 1/2 w	REC-20BF
R113	120 k	±5% 1/2 w	REC-20BF
R114	20 k	±5% 1/2 w	REC-20BF
R115	4.7 k	±5% 1/2 w	REC-20BF
R116	1.5 k	±5% 1/2 w	REC-20BF
R117	1 k	±5% 1/2 w	REC-20BF
R118	1.5 k	±5% 1/2 w	REC-20BF
R119	220	±5% 1/2 w	REC-20BF
R120	1 k	±5% 1/2 w	REC-20BF
R121	12	±5% 1/2 w	REC-20BF

CAPACITORS			
C1	0.0995-0.0999		505-499
C2	220 pf	±2% 500 dcwv	COM-20E
C3	0.0056	±10% 500 dcwv	COM-30B
C4	180 pf	±5% 500 dcwv	COM-20D
C5	5.6 pf	±10%	COC-1
C6	0.33	±10% 100 dcwv	COW-17
C7	47 pf	±10% 500 dcwv	COM-15B
C8	0.022	±10% 100 dcwv	COW-17
C101	1.0	±2% 200 dcwv	COP-19
C101A	Supplied by laboratory		
C102	1.0	±10% 100 dcwv	COW-17
C103	60	25 dcwv	COE-47
C104	60	25 dcwv	COE-47
C105	0.1	±10% 600 dcwv	COL-71
C106	5	50 dcwv	COE-57
C107	60	25 dcwv	COE-47
C108	60	25 dcwv	COE-47
C109	0.01	±1% 500 dcwv	COM-1F
C110	0.01	±1% 500 dcwv	COM-1F
C111	0.02	±1% 300 dcwv	COM-1F
C112	60	25 dcwv	COE-47
C113	60	25 dcwv	COE-47
C114	60	25 dcwv	COE-47
C115	0.022	±20% 500 dcwv	COC-63
C116	5	50 dcwv	COE-57

MISCELLANEOUS		
B1	BATTERIES, 1.5 v (4)	D CELLS
D102	DIODE	2RE-1009/1N91
L1	INDUCTOR, 45 mh ±5%	ZCHA-57
M1	METER	MEDS-86
S1	SWITCH	SWRW-172
S2	SWITCH	SWRW-173
S3	SWITCH	SWRW-174
S4	SWITCH	SWT-333A,NP
T1	TRANSFORMER	746-432
TR1	TRANSISTOR	2N1415
TR2	TRANSISTOR	TR31/2N445A (BR)
TR3	TRANSISTOR	TR31/2N445A (BR)
TR4	TRANSISTOR	TR31/2N445A (BR)

NOTES

GR Type designations for resistors and capacitors are as follows:

COC - Capacitor, ceramic	COW - Capacitor, wax
COE - Capacitor, electrolytic	POSC - Potentiometer, composition
COL - Capacitor, oil	REC - Resistor, composition
COM - Capacitor, mica	REF - Resistor, film
COP - Capacitor, plastic	

All resistances are in ohms except as otherwise indicated by k (kilohms).

All capacitances are in microfarads, except as otherwise indicated by pf(picofarads).

When ordering replacement components, be sure to include complete description as well as Part Number. (Example: R85, 51k ±10%, 1/2w, REC-20BF).

TYPE 1650-A IMPEDANCE BRIDGE

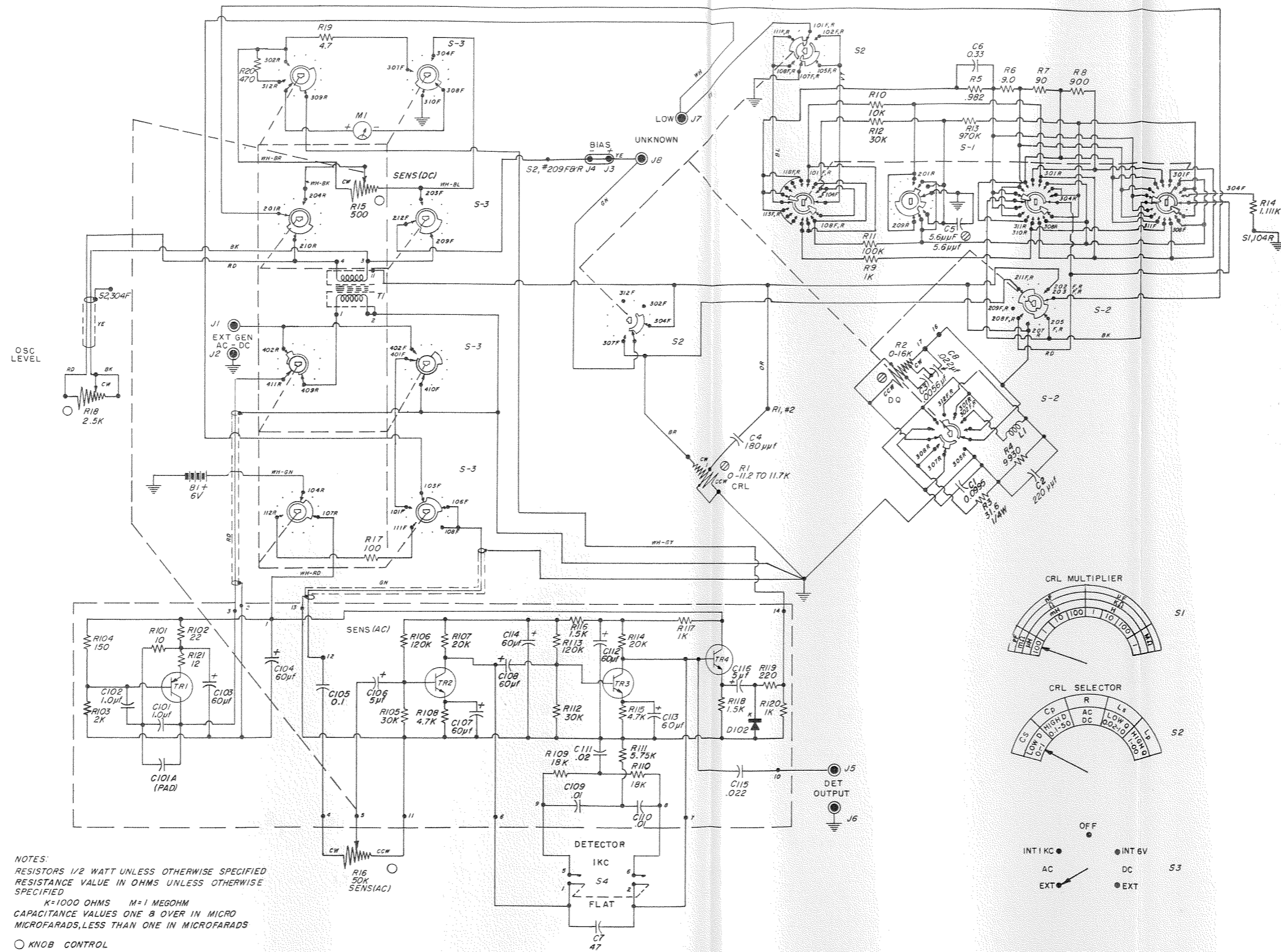

NOTES:
 RESISTORS 1/2 WATT UNLESS OTHERWISE SPECIFIED
 RESISTANCE VALUE IN OHMS UNLESS OTHERWISE SPECIFIED
 K=1000 OHMS M=1 MEGOHM
 CAPACITANCE VALUES ONE & OVER IN MICRO
 MICROFARADS, LESS THAN ONE IN MICROFARADS
 ○ KNOB CONTROL
 ⊗ SCREW DRIVER CONTROL
 A.T. USED #1 THRU #17

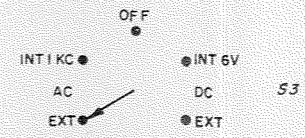
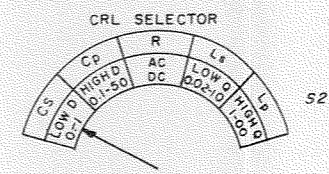
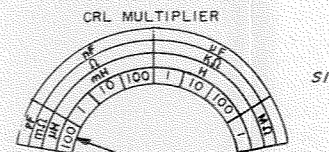

Figure 22. Schematic Diagram.

HHCBA

APPENDIX A

NOMOGRAPH FOR CONVERSION OF C, L, D AND Q AT 1 KC

The nomograph below greatly simplifies the process of converting from series to parallel values (or vice versa) of inductance and capacitance, for values of dissipation factor up to 10 (Q down to 0.1). To illustrate use of the nomograph, assume a parallel capacitance of 2 μf , and a D of 7. A straight line connecting these two points is seen to cross the center (C_s) bar at 100. Therefore, the equivalent series capacitance is 100 μf .

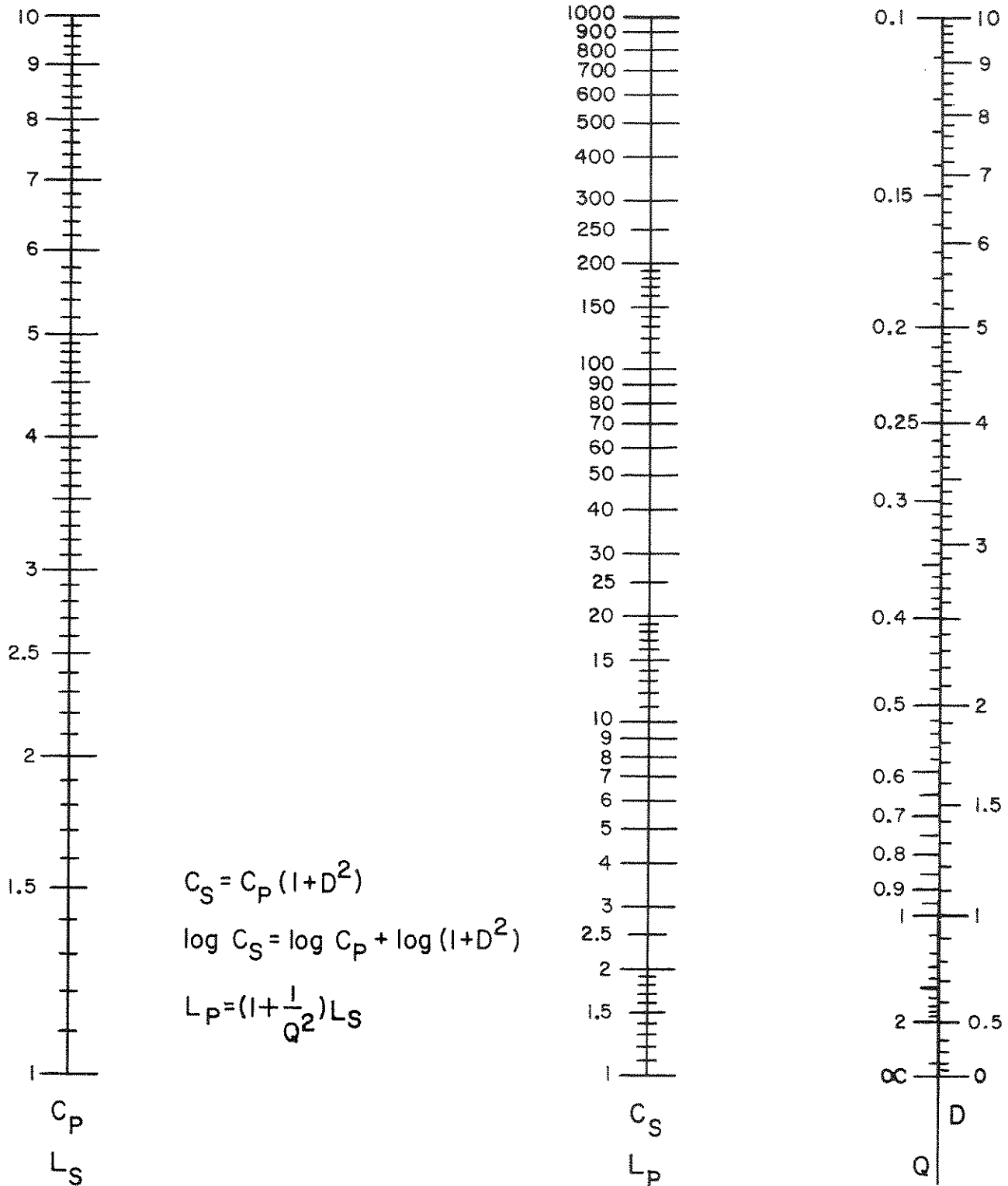

GENERAL RADIO COMPANY

WEST CONCORD, MASSACHUSETTS

EMERSON 9-4400

MISSION 6-7400

DISTRICT OFFICES

NEW YORK

Broad Ave. at Linden, Ridgefield, N. J.
Telephone N.Y. WORTH 4-2722
N.J. WHITNEY 3-3140

SYRACUSE

Pickard Bldg.
East Molloy Rd., Syracuse 11, N. Y.
Telephone GLENVIEW 4-9323

PHILADELPHIA

1150 York Rd., Abington, Penna.
Telephone TURNER 7-8486
Phila., HANCOCK 4-7419

WASHINGTON

8055 13th St., Silver Spring, Md.
Telephone JUNIPER 5-1088

FLORIDA

113 East Colonial Drive, Orlando, Fla.
Telephone GARDEN 5-4671

CHICAGO

6605 West North Ave., Oak Park, Ill.
Telephone VILLAGE 8-9400

LOS ANGELES

1000 N. Seward St., Los Angeles 38, Calif.
Telephone HOLLYWOOD 9-6201

SAN FRANCISCO

1186 Los Altos Ave., Los Altos, Calif.
Telephone WHITECLIFF 8-8233

CANADA

99 Floral Pkwy., Toronto 15, Ont.
Telephone CHERRY 6-2171

REPAIR SERVICES

EAST COAST

General Radio Company
Service Department
22 Baker Ave., W. Concord, Mass.
Telephone EMERSON 9-4400

NEW YORK

General Radio Company
Service Department
Broad Ave. at Linden, Ridgefield, N. J.
Telephone N.Y. WORTH 4-2722
N.J. WHITNEY 3-3140

MIDWEST

General Radio Company
Service Department
6605 West North Ave., Oak Park, Ill.
Telephone VILLAGE 8-9400

WEST COAST

General Radio Company
Service Department
1000 N. Seward St.
Los Angeles 38, Calif.
Telephone HOLLYWOOD 9-6201

CANADA

General Radio Company
Service Department
99 Floral Pkwy., Toronto 15, Ont.
Telephone CHERRY 6-2171

General Radio Company (Overseas), Zurich, Switzerland
Representatives in Principal Overseas Countries



13563

Printed in USA