

GENERAL RADIO COMPANY

WEST CONCORD, MASSACHUSETTS*

EMerson 9-4400

Mission 6-7400

SALES ENGINEERING OFFICES

METROPOLITAN NEW YORK*

Broad Avenue at Linden
Ridgefield, New Jersey
Telephone N.Y. WOrth 4-2722
N.J. WHitney 3-3140

SYRACUSE

Pickard Building
East Molloy Road
Syracuse 11, New York
Telephone GLenview 4-9323

PHILADELPHIA

1150 York Road
Abington, Pennsylvania
Telephone TUrner 7-8486
Phila., HAncock 4-7419

WASHINGTON* AND BALTIMORE

Rockville Pike at Wall Lane
Rockville, Maryland
Telephone 946-1600

ORLANDO

113 East Colonial Drive
Orlando, Florida
Telephone GArden 5-4671

* Repair services are available
at these district offices.

CHICAGO*

6605 West North Avenue
Oak Park, Illinois
Telephone Village 8-9400

CLEVELAND

5579 Pearl Road
Cleveland 29, Ohio
Telephone 886-0150

LOS ANGELES*

1000 North Seward Street
Los Angeles 38, California
Telephone HOLlywood 9-6201

SAN FRANCISCO

1186 Los Altos Avenue
Los Altos, California
Telephone WHitecliff 8-8233

DALLAS

2501-A West Mockingbird Lane
Dallas 35, Texas
Telephone FLeeewood 7-4031

TORONTO*

99 Floral Parkway
Toronto 15, Ontario, Canada
Telephone CHerry 7-2171

MONTREAL BRANCH

Office 395 1255 Laird Boulevard
Town of Mount Royal, Quebec, Canada
Telephone 737-3673

General Radio Company (Overseas), Zurich, Switzerland
Representatives in Principal Overseas Countries

Printed in USA

OPERATING INSTRUCTIONS



TYPE 1602-B

ADMITTANCE METER

GENERAL RADIO COMPANY

H

OPERATING INSTRUCTIONS

TYPE **1602-B**

ADMITTANCE METER

Form 1602-0110-H
January, 1964

G E N E R A L R A D I O C O M P A N Y
WEST CONCORD, MASSACHUSETTS, USA

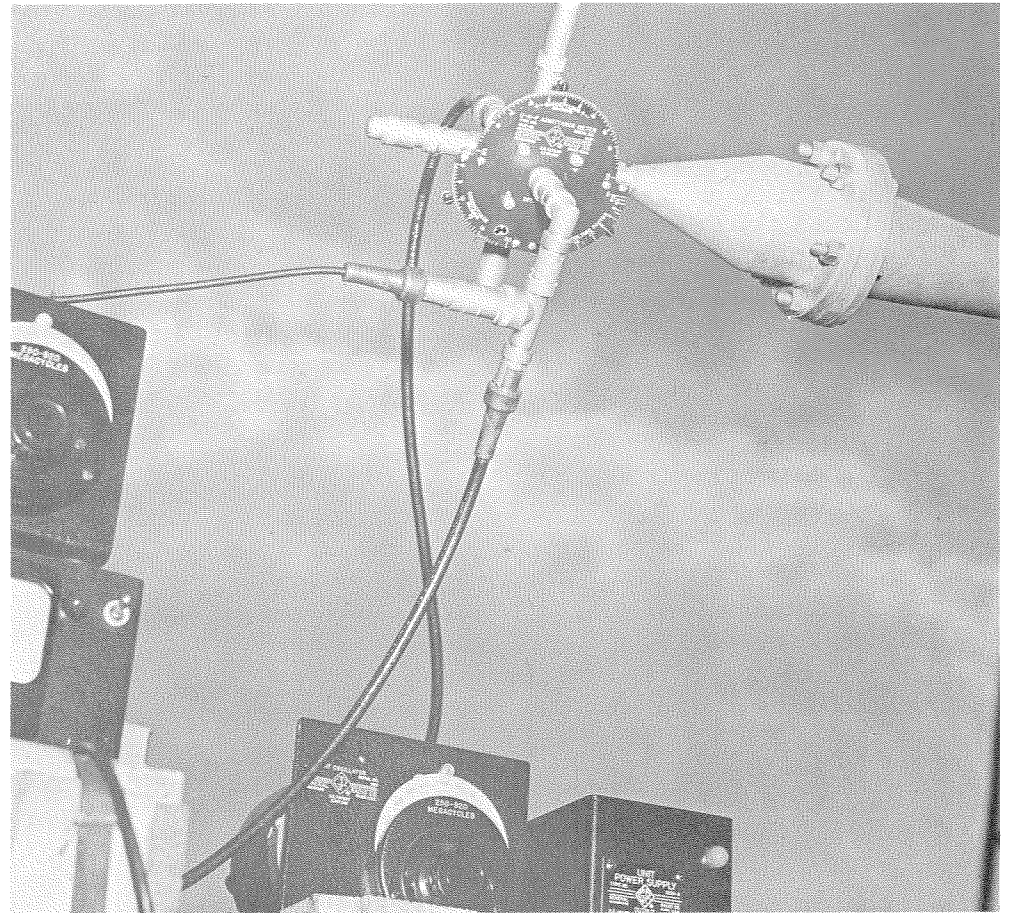

Field setup for measurements on a UHF-TV transmitting antenna.

TABLE OF CONTENTS

SPECIFICATIONS

FRONTISPIECE

1.0 DESCRIPTION

1.1 GENERAL DESCRIPTION	1
1.2 CIRCUIT	2
1.3 CONTROLS AND CONNECTIONS	4
1.4 ACCESSORIES SUPPLIED	7

2.0 OPERATION

2.1 GENERATOR AND DETECTOR	7
2.2 R-F LEAKAGE	13
2.21 Sources of Leakage	13
2.22 Leakage Checks	14
2.3 MEASUREMENTS ON COAXIAL CIRCUITS HAVING A 50-OHM CHARACTERISTIC IMPEDANCE	15
2.31 Admittance Measurements	15
2.311 Method	15
2.312 Line-Length Corrections for Admittance Measurements	16
2.3121 Use of the Type 874-LK20 Constant-Impedance Adjustable Line to Eliminate Line-Length Corrections	17
2.31211 Example of Admittance Measurement Using a Type 874-LK20 Adjustable Line	19
2.3122 Measurement of Impedance Using the Type 874-LK20 Constant-Impedance Adjustable Line.	20
2.31221 Example of Impedance Measurement Using a Type 874-LK20 Adjustable Line	20
2.3123 Line-Length Correction Using the Smith Chart	21
2.3124 Line-Length Corrections Using Transmission-Line Equations	23
2.3125 Determination of Electrical Length of Line	23
2.3126 Effect of Line Loss on Line-Length Corrections	26
2.31261 Measurement of Line Loss	26
2.31262 Correction for Line Loss	27
2.3127 Methods of Short- and Open-Circuiting a Line	29
2.32 Admittance to Impedance Conversion Using Smith Chart	30
2.321 Measurement of Resistive Component of High-Q Element	30
2.33 Standing-Wave Ratio and Reflection Coefficient Measurements	32
2.331 VSWR Measurements Using the Null Method	32
2.332 Direct Reflection Coefficient and VSWR Measurements	33
2.34 Impedance Matching to a 50-Ohm Line	35
2.35 Admittance or Impedance Comparison	35
2.36 Measurement of Impedance Magnitude Directly	36

2.4 T-V TRANSMITTING ANTENNA MEASUREMENTS	36
2.41 UHF-TV Transmitting Antenna Measurements	36
2.411 VSWR Measurements	39
2.4111 Voltage-Ratio Method	39
2.4112 Null Method	40
2.412 Admittance Measurements	41
2.42 VHF-TV Transmitting Antenna Measurements	41
2.5 MEASUREMENTS ON LINES HAVING IMPEDANCES OTHER THAN 50 OHMS	44
2.51 Impedance and Admittance Measurements on 72-75 Ohm Lines	44
2.52 Reflection Coefficient and VSWR Measurements on 72-75 Ohm Lines	45
2.53 Measurements on Lines having Other Impedances	46
2.6 MEASUREMENTS ON BALANCED LINE CIRCUITS	46
2.7 MEASUREMENTS ON COMPONENTS AND LUMPED CIRCUITS	47
2.71 Example of the Measurement of a Resistor using the Type 874-LK Line	52
2.72 Example of the Measurement of a Resistor Without the Type 874-LK Line	53
2.8 OPERATION AT FREQUENCIES BELOW 40 MC	54
2.9 OPERATION AT FREQUENCIES ABOVE 1000 MC	57
2.10 ERRORS	57
2.101 Correction for Cross-Coupling Errors	57
2.1011 Example of Cross-Coupling Correction Using Chart	58
2.1012 Example of Cross-Coupling Correction Using Equations	58
2.102 Junction Inductance Errors	58
3.0 CHECKS AND ADJUSTMENTS	60
3.1 CHECKING CALIBRATION OF SUSCEPTANCE STANDARD	60
3.2 SERVICING THE SUSCEPTANCE STANDARD STUB	60
4.0 ACCESSORY MULTIPLIER PLATES	62

SPECIFICATIONS

RANGE: Theoretically, zero to infinity; practically, the lower limit is determined by the smallest readable increment on the scale, which is 100 microhos (0.1 millimho). The upper limit is 1000 millimhos. Range is the same for both conductance and susceptance, but susceptance can be either positive or negative, i.e., the susceptance dial is calibrated from -20 to +20 millimhos. Multiplying factors from 1 to 20 are provided, and factors from 20 to 100 can be determined approximately.

With Multiplier Plates, Types 1607-P10, -P11, the smallest readable increment is 0.01 millimho; the upper limit is 10,000 millimhos. Multiplying factors from 10 to 200 are provided; those from 200 to 1000 can be determined approximately.

Standing-wave ratios as high as 10 can be readily measured by a voltage-ratio method. VSWR less than 1.2, can be measured by a direct-reading method in which the magnitude is determined from the meter reading of a Type DNT Detector without adjustment of the admittance Meter controls.

ACCURACY: For both conductance and susceptance (up to 1000 Mc):

from 0 to 20 millimhos $\pm(3\% + 0.2 \text{ millimho})$;

from 20 to ∞ millimhos $\pm(3\% \sqrt{M} + 0.2 \text{ millimho})$, where M is the scale multiplying factor. When the Multiplier Plates are used, the fixed error of 0.2 millimho is reduced to approximately 0.04 millimho.

Above 1000 Mc, errors increase slightly, and, at 1500 Mc, the basic figure of 3% in the expression above becomes 5%. For matching impedances to 50 ohms, the accuracy is 3% up to 1500 Mc.

FREQUENCY RANGE: 40 to 1500 Mc, direct-reading. Range can be extended downward to 20 Mc, if a frequency correction is applied to the susceptance reading.

ACCESSORIES SUPPLIED: Two Type 1602-P4 50- Ω Termination, for use as conductance standards; one Type 1602-P1 Adjustable Stub and one Type 1602-P3 Variable Air Capacitor, for susceptance standards; two Type 874-R22LA Patch Cords for connections to generator and detector; and one Type 874-PB58A Panel Connector, Type 1602-P10 and P11 Multiplier Plates. A wooden storage box is furnished.

OTHER ACCESSORIES REQUIRED: Generator and detector: Generator should cover desired frequency range and deliver between 1 volt and 10 volts. Type 1208-C (65 to 500 Mc), Type 1215-C (50 to 250 Mc), Type 1209-C (250 to 960 Mc) and Type 1218-A (900 to 2000 Mc) Unit Oscillators and the Type 1361-A Oscillator (50 to 1000 Mc) are recommended. The Type 1021-AU and -AV Generators are also satisfactory.

Detector sensitivity should be better than 10 microvolts. Recommended is the General Radio Type DNT Detector, which consists of a Type 874-MR Mixer Rectifier, a Type 1216-A Unit I-F Amplifier, and a Unit Oscillator to provide the heterodyning frequency.

OTHER ACCESSORIES AVAILABLE: Type 874-Z Stand for supporting rigid lines; Type 874-LK20L Constant-Impedance Adjustable Line for eliminating line-length correction; Type 874-UBL Balun for measurements on balanced lines. For measurements of circuit components, such as resistors, capacitors, and inductors, a Type 874-ML Component Mount is recommended.

TERMINALS: All instrument terminals (except the detector) are Type 874 Locking Coaxial Connectors. Locking Type 874 Connectors are used on accessories supplied. Adaptors are available for other coaxial systems.

DIMENSIONS: Width 5½, height 7½, depth 5½ inches (140 by 195 by 140 mm), without standards or unknown.

NET WEIGHT: 8¼ pounds (3.8 kg).

The following Smith chart forms are available:

TITLE	FORM NO.
Impedance Coordinates - 50-Ohm Characteristic Impedance	5301-7569
Admittance Coordinates - 20-Millimho Characteristic Admittance	5301-7568
Impedance or Admittance Coordinates - Normalized	5301-7560
Impedance or Admittance Coordinates - Normalized Expanded	5301-7561

QUANTITY	50	100	200	500	1000
PRICE	2.00	3.75	7.00	14.00	25.00

For a more complete description of this instrument, refer to the General Radio Experimenter, Volume 28, No. 3, August, 1953 and Volume 34, No. 5, May, 1960.

U.S. Patent Number 2,548,457.

Operating Instructions for Type 1602-B Admittance Meter

1.0 DESCRIPTION

1.1 GENERAL DESCRIPTION

The Type 1602-B U-H-F Admittance Meter is a simple, flexible instrument for the measurement of admittance and impedance over a wide frequency range. As a null instrument the U-H-F Admittance Meter can be used to measure the conductance and susceptance of an unknown circuit directly. It can also be used as a comparator to indicate equality of one admittance to another, or degree of departure of one from the other. As a direct indicating device, in addition, it can be used to determine the magnitude of the reflection coefficient on a 50-ohm coaxial line or the magnitude of an unknown impedance from ratios of output voltages read on a meter.

When the admittance meter is used in conjunction with an adjustable-length coaxial line having a uniform characteristic impedance, such as the Type 874-LK20 Constant-Impedance Adjustable Line, impedance and admittance measurements can be simplified as the correction for the length of transmission line between the unknown and the instrument can be eliminated. Also when the admittance meter is used with a wide-range balun of the proper type, such as the Type 874-UB Balun, accurate measurements can be easily made on balanced circuits over a wide frequency range.

The instrument is best suited to measurements on coaxial-line circuits having a 50-ohm characteristic impedance, but, in addition, measurements can be made on components or on coaxial-line circuits having characteristic impedances different from 50 ohms. The nominal frequency range of the instrument is from 40 to 1500 Mc, but measurements can be made at frequencies as low as 10 Mc. For admittance measurements using the null method, the magnitude of the conductive component of the unknown admittance is indicated directly on a scale which is calibrated from 0 to 20 millimhos. The magnitude of the susceptive component is indicated on another scale which is calibrated from -20 to 0 to +20 millimhos. A third scale on the dial indicates the multiplier used which applies to both other scales. The multiplying-factor scale is calibrated from 1 to infinity. Therefore, theoretically, the instrument can measure admittances from zero to infinity; however, at either extreme the ac-

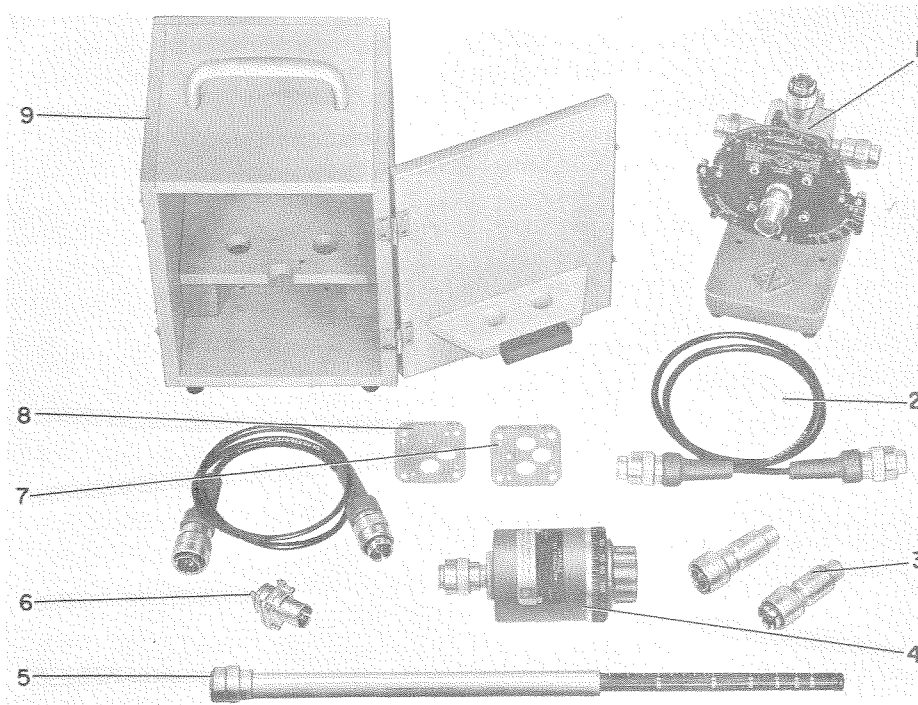

LEGEND

INDEX	TYPE NO.	NOMENCLATURE	QUANTITY
1.	1602-B	U-H-F Admittance Meter	1
2.	874-R22LA	Coaxial Patch Cord	2
3.	1602-P4	Termination (50Ω)	2
4.	1602-P3	Variable Air Capacitor	1
5.	1602-P1	Adjustable Stub (20 cm)	1
6.	874-PB58A	Coaxial Panel Connector	1
7.	1607-P10	Multiplier Plate (Single)	1
8.	1607-P11	Multiplier Plate (Double)	1
9.	1602-0330	Carrying Box Assembly	1

Type 1602-B U-H-F Admittance Meter and Accessories Supplied.

curacy becomes poor because the dials cannot be read or set accurately. The instrument can also be used to advantage for matching a load to a line, as the instrument can be set up to indicate a matched condition when the output is zero; therefore, a continuous indication of the quality of the match is indicated by the output from the detector.

1.2 CIRCUIT

Although the Type 1602-B Admittance Meter makes use of a null indication for measurements, it is not a true bridge. In the admittance meter the currents flowing in three coaxial lines fed from a common source at a common junction point are sampled by three adjustable loops, which couple to the magnetic field in each line as shown in Figure 1.

The coupling of each of the loops can be varied by rotation of the loop. One of the coaxial lines is terminated in a conductance standard, which is a pure resistance equal to the characteristic impedance of the line, one in a susceptance standard, which is a short-circuited length of coaxial line, and one in the unknown circuit. The outputs of the three loops are combined by connecting all three loops in parallel, and when the loops are properly oriented, the combined output is zero. The device therefore balances in the same manner as a bridge.

At balance the vector sum of the voltages induced in the three loops is proportional to the mutual inductance, M , and to the current flowing in the corresponding line. Since all three lines are fed from a common source, the input voltage is the same for each line and the current flowing in each line is proportional to the input admittance.

The voltage, V_G , induced in the conductance loop is

$$V_G = KM_G G_S \tag{1}$$

Figure 1. Schematic diagram of admittance meter circuit, with standards, generator, and null detector connected for admittance measurements.

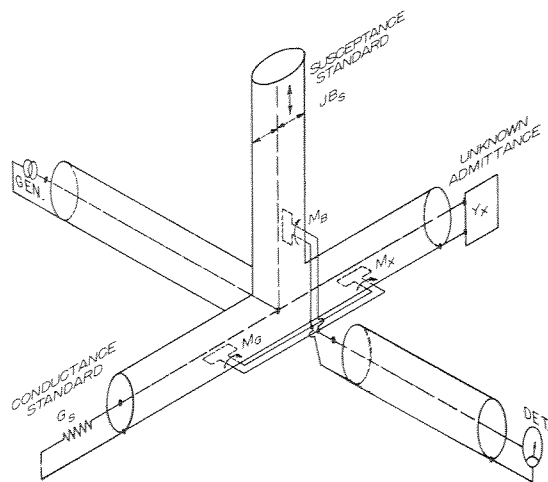

where M_G is the mutual coupling between the conductance standard line and conductance loop, and G_S is the magnitude of the conductance standard. Since the coaxial line has a characteristic admittance of 20 millimhos (characteristic impedance of 50 ohms) and G_S is chosen to be equal to the characteristic admittance of the line, Y_0 , $G_S = Y_0 = 20$ millimhos.

The voltage, V_B , induced in the susceptance loop is

$$V_B = jKM_B B_S \tag{2}$$

where M_B and B_S are the respective coupling and magnitude of the standard susceptance. In the admittance meter a variable capacitor is used as the susceptance standard at frequencies below 150 Mc, and a stub line with an adjustable short circuit is used at higher frequencies. The variable capacitor or stub line is set at the operating frequency to produce a susceptance having a magnitude equal to that of the characteristic admittance or 20 millimhos, $|B_S| = |Y_0|$. The variable capacitor produces a capacitive standard susceptance in which case B_S has a positive sign. When the stub line is used at frequencies between 150 and 450 Mc, the required susceptance is obtained by setting the stub to produce a short-circuited line one-eighth of a wavelength long, in which case, B_S has a negative sign. At frequencies between 450 and 1000 Mc, a three-eighths wavelength line is used and B_S is positive.

The voltage, V_X , induced in the "unknown" loop is

$$V_X = KM_X Y_X = KM_X (G_X + jB_X) \tag{3}$$

where M_X and Y_X are the coupling between the unknown line and the unknown loop, and admittance seen at a point directly under the center of the unknown loop respectively.

At balance, the sum of the three voltages must be zero, therefore,

$$M_X (G_X + jB_X) + M_G G_S + jM_B B_S = 0 \tag{4}$$

The real and imaginary parts can be separated and the following expressions for the components of the unknown admittance obtained.

$$G_X = -\frac{M_G}{M_X} G_S \tag{5}$$

$$B_X = -\frac{M_B}{M_X} B_S \tag{6}$$

Since G_S and B_S are constants, the M_G scale can be calibrated in terms of G_X , the M_B scale in terms of B_X , and the M_X scale in terms of a multiplying factor which applies to both of the other two scales. Since each coupling can be varied through zero by rotation of the loop, the two balance equations show that the theoretically measurable ranges of conductance and susceptance extend from zero to infinity. However, the percentage accuracy of the measurements decreases as zero coupling is approached (corresponding to a multiplying factor approaching infinity) due to loss of scale reading accuracy and

other errors¹, and a 1 millimho to 400 millimhos range is found practical for reading and setting².

The loops associated with the unknown admittance and the standard conductance can each be rotated through an angle of 90° , but the loop associated with the standard susceptance is arranged to be rotatable through an angle of 180° , thus allowing the measurement of positive as well as negative values of unknown susceptance with a single susceptance standard.

A unique feature of the U-H-F Admittance Meter, which distinguishes it from bridges and other null devices, is that the susceptance scale, as well as the conductance scale, is independent of frequency. This comes about because the susceptance standard is always adjusted to produce the same magnitude of susceptance at each frequency.

1.3 CONTROLS AND CONNECTIONS

The orientations of the three loops coupling to the three lines are adjusted by means of the arms attached to the rotatable barrels containing the loops. The relative coupling of each loop is indicated by the reading of the calibrated scale on the dial corresponding to the position of the indicator mounted on the end of each arm, as shown in Figures 2a and 2b.

The scale used to indicate SUSCEPTANCE in admittance measurements using the null method is located at the top of the dial and is calibrated from -20 to 0 to +20 millimhos over a 180° arc. The sign of the susceptance is determined by the scale on the Type 1602-P1 or P3 Calibrated Susceptance Standard used, the white + and - signs corresponding to the white frequency scale, and the orange signs corresponding to the orange frequency scale.^{3,4}

The scale used to indicate CONDUCTANCE in admittance measurements using the null method is located in the lower-left quadrant of the dial and is calibrated from 0 to 20 millimhos over a 90° arc.

The stop on the conductance arm is adjusted to permit the indicator to be set slightly below zero. This allows the instrument to be balanced to a complete null when a low-loss circuit is being measured under conditions in which the errors in the instrument make the conductance measure lower than it actually is.⁵

The scale used to indicate the MULTIPLYING FACTOR in admittance

¹See Section 2.10. ²See Specifications.

³The white scales correspond to $1/8$ wavelength settings and the orange scales to $3/8$ wavelength settings.

⁴The Type 1602-P3 Variable Air Capacitor is calibrated from 41 to 150 Mc and the orange + and - signs on the susceptance dial should be used as the standard susceptance is positive.

⁵See Section 2.10.

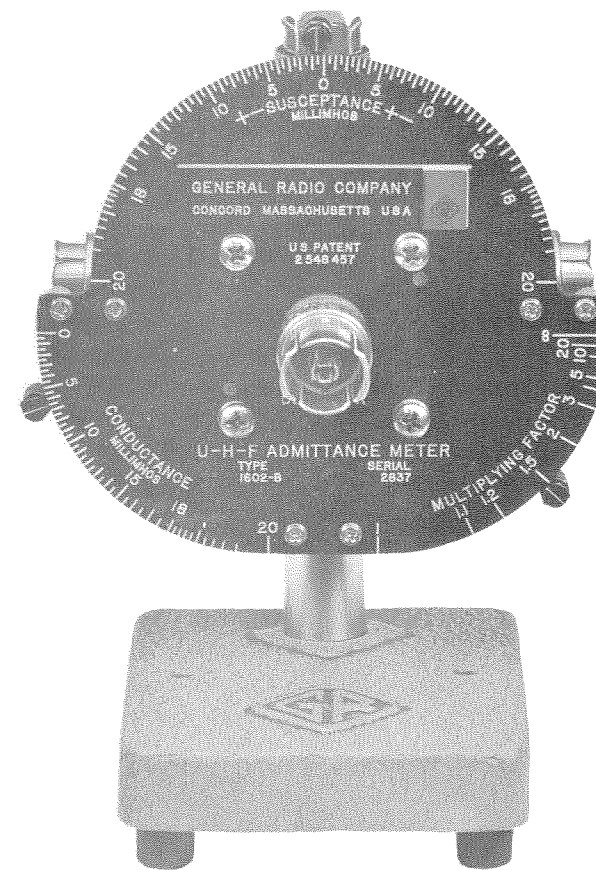

Figure 2a. Front View of Type 1602-B Admittance Meter

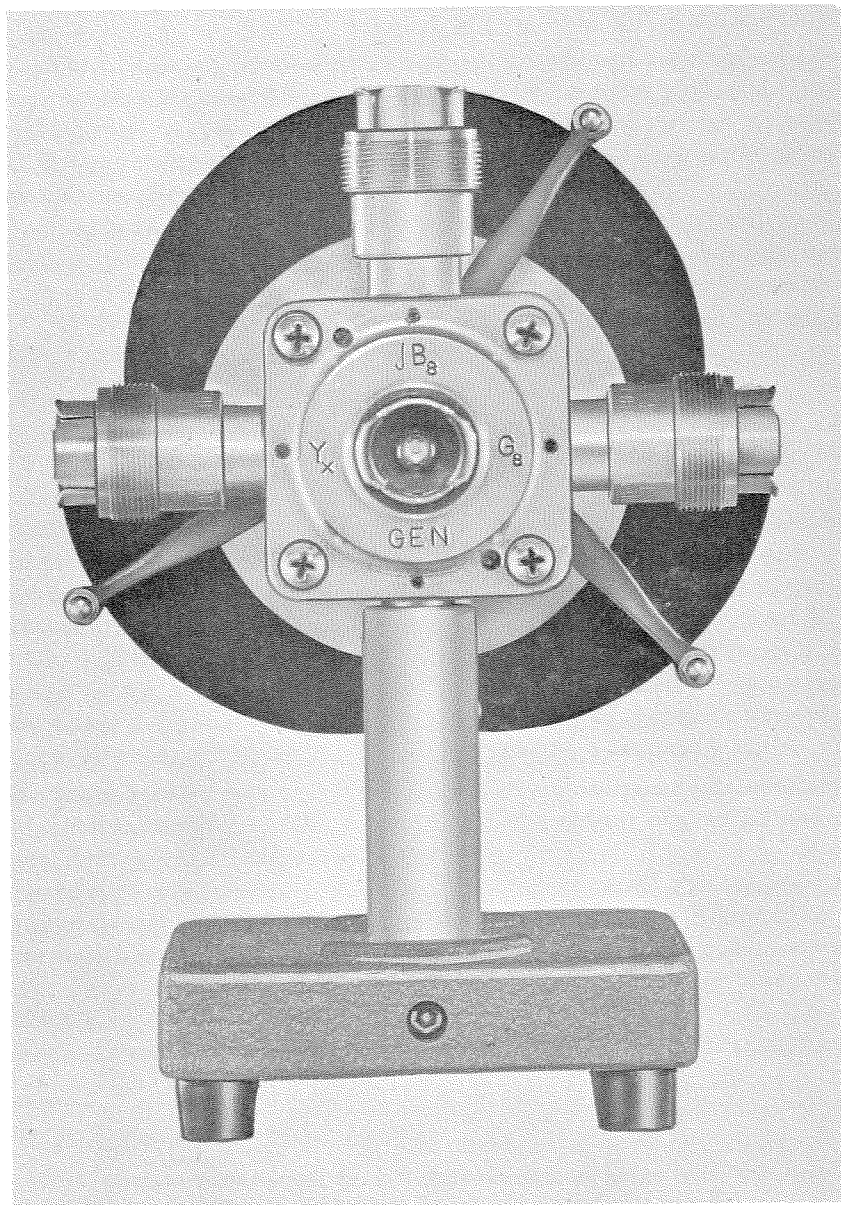

Figure 2b. Rear View of Type 1602-B Admittance Meter

measurements using the null method is located in the lower right quadrant of the dial and is calibrated from 1 to infinity over a 90° arc.

The GENERATOR coaxial connector is located at the rear of the junction block while the DETECTOR connection is made at the center of the dial.

For admittance measurements the standard conductance is connected to the connector adjacent to the G_s engraved on the rear of the junction block, the standard susceptance connected to the connector adjacent to the jB_s engraved on the rear of the junction block, and the circuit under test connected to the connector adjacent to the Y_x engraved on the rear of the junction block.

The admittance meter is provided with Type 874 Coaxial Connectors which have a 50.0-ohm characteristic impedance. If the circuit under test is fitted with connectors other than Type 874 Connectors, low-reflection adaptor units should be used to make the connection between the circuit under test and the unknown connector on the admittance meter. Low-reflection adaptors and other coaxial components are listed in the Table at the end of this manual.

1.4 ACCESSORIES SUPPLIED

Two Type 1602-P4 50-ohm Termination Units are supplied: one for use as the standard conductance, one for general use, such as VSWR measurements.

One Type 1602-P1 Calibrated Stub and one Type 1602-P3 Variable Air Capacitor are supplied for use as susceptance standards. The Type 1602-P1 Calibrated Stub is calibrated for use over the frequency range from 150 to 1000 Mc, and the Type 1602-P3 Variable Air Capacitor is calibrated for use from 40 to 150 Mc. The indicator for the scales on the stub is the end of the metal tube into which the bakelite rod slides. The susceptance standards are calibrated for use with the instrument bearing the same serial number.

Two Type 874-R22LA Patch Cords are provided for making connections to the generator and detector.

Two Multiplier Plates, Types 1602-P10 and -P11, are provided for range extension.

A Type 874-PB58A is provided for installation on the detector, if needed.

2.0 OPERATION

2.1 GENERATOR AND DETECTOR

Both the generator and detector used should be well shielded to minimize r-f leakage, and both instruments should be fitted with completely coaxial connectors. The output voltage requirement on the generator depends on the sensitivity of the detector used and the operating frequency. Over most of the operating frequency band, a generator output voltage of 1 volt is adequate if the detector sensitivity, that is the minimum detectable signal, is better than 5 microvolts. At the extreme upper and lower frequency limits the generator voltage or detector sensitivity requirements are somewhat greater.

Generators

The following oscillators are satisfactory generators:

Type No.	Frequency Range
1211 Unit Oscillator	0.5 to 50 Mc
1215 Unit Oscillator	50 to 250 Mc
1208 Unit Oscillator	65 to 500 Mc
1209-C Unit Oscillator	250 to 960 Mc
1209-CL Unit Oscillator	180 to 600 Mc
1218 Unit Oscillator	900 to 2000 Mc
1361 UHF Oscillator	450 to 1050 Mc

The insertion of a Type 874-G10 10 db Pad between any of the generators listed above and the admittance meter is recommended to minimize frequency pulling of the oscillator if sufficient sensitivity is available. The following signal generators also can be used as generators:

Type No.	Frequency Range
805-D	16 kc to 50 Mc
1021-AV	40 to 250 Mc
1021-AU	250 to 940 Mc

Since signal generators are loosely coupled, no pad should be used.

Detectors

The detector used should be well-shielded and should have a sensitivity of the order of 10 μ v or better. The combination of a Type 874-MR Mixer Rectifier, Type 1216-A-30 Mc-I-F Amplifier,⁸ and a unit oscillator covering the desired frequency range forms a very satisfactory detector. (See Figure 2c.)

The Type 874-MR Mixer Rectifier is a crystal mixer which heterodynes the unbalance signal from the admittance meter with the signal from the local oscillator producing a signal of the frequency to which the i-f amplifier is tuned. This unit is well-shielded and has a sensitivity (minimum detectable signal) of approximately 5 microvolts.

The frequency range of the detector, operating on the fundamental of the local oscillator, extends 30 Mc above and below the frequency limits of the local oscillator used. Following is a chart of fundamental frequency detector ranges with various unit oscillators:

⁸A communications receiver having a bandwidth of at least 20 Kc and covering frequencies below 40 Mc can be used in place of the Type 1216-A I-F Amplifier.

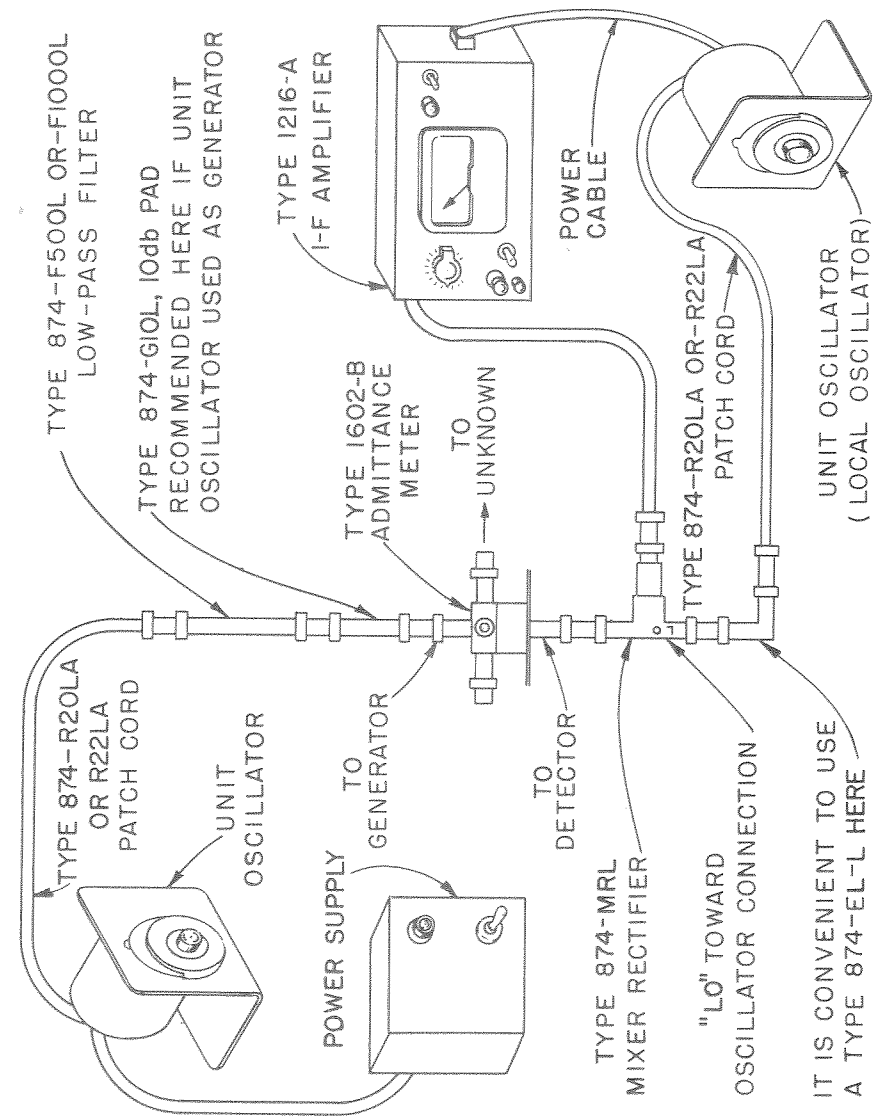

Figure 2c. Diagram of a measurement setup using a unit oscillator as a generator and the combination of a mixer rectifier, unit oscillator, and i-f amplifier as a detector.

Type No.	Frequency Range	Consists of Type
DNT-1	40-530 Mc	874-MRL Mixer Rectifier, 1216-A I-F Amplifier, 874-F500L Low-Pass Filter, 874-EL-L Ell, 1208-C Unit Oscillator, 874-G10L 10-DB Pad
DNT-2	40-280 Mc	874-MRL Mixer Rectifier, 1216-A I-F Amplifier, 874-F500L Low-Pass Filter, 874-EL-L Ell, 1215-C Unit Oscillator, 874-G10L 10-DB Pad
DNT-3	220-950 Mc	874-MRL Mixer Rectifier, 1216-A I-F Amplifier, 874-F1000L Low-Pass Filter, 874-EL-L Ell, 1209-C Unit Oscillator, 874-G10L 10-DB Pad
DNT-4	870-2030 Mc	874-MRL Mixer Rectifier, 1216-A I-F Amplifier, 874-EL-L Ell, 1218-A Unit Oscillator, 874-G10L 10-DB Pad

Signals much higher in frequency than the top limit of the local oscillator can be detected, with some sacrifice in sensitivity, by operating on harmonics of the local oscillator. However, at the higher frequencies care must be taken not to tune to a harmonic of the signal frequency, beating with a harmonic of the local oscillator frequency, rather than to the signal fundamental. This can also be a problem in fundamental operation of the local oscillator, but on harmonic operation the desired and undesired responses are closer together and more likely to be confused. The desired response cannot always be identified by choosing the strongest signal as the admittance meter may be set close to a null at the signal frequency, but is far off balance at harmonic frequencies. Hence, the apparent strength of harmonics may be increased many orders of magnitude. One of the best ways of eliminating possible confusion is to insert a low-pass filter and drastically attenuate all harmonics. This method will be described in greater detail in a succeeding paragraph. If a filter is not used, the fundamental response can be maximized when the local oscillator is adjusted by setting the MULTIPLYING FACTOR at ∞ and the CONDUCTANCE and SUSCEPTANCE indicator at 20.

Since the Type 1216-A Amplifier is tuned to 30 Mc, the local oscillator must be set approximately 30 Mc above or below the signal frequency when operating on the fundamental of the local oscillator and, in the general case, at

$$f_{LO} = \frac{f_s \pm 30}{n} = \frac{f_s}{n} \pm \frac{30}{n} \quad (7a)$$

where f_s is the signal frequency, f_{LO} is the local oscillator frequency, and n is the harmonic of the local oscillator used. Hence, on fundamental local-oscillator operation two approximately equal responses can be obtained at local oscillator settings differing by 60 Mc. For harmonic operation the sepa-

ration is $\frac{60}{n}$. The actual signal frequency, f_s , corresponding to two equal responses at frequencies of f_1 and f_2 is:

$$f_s = \frac{30 \times (f_2 + f_1)}{f_2 - f_1} \quad (7b)$$

If the fundamental, second, and third harmonics of the signal frequency are present, in the vicinity of the signal frequency the responses shown in Figure 2d can be obtained:

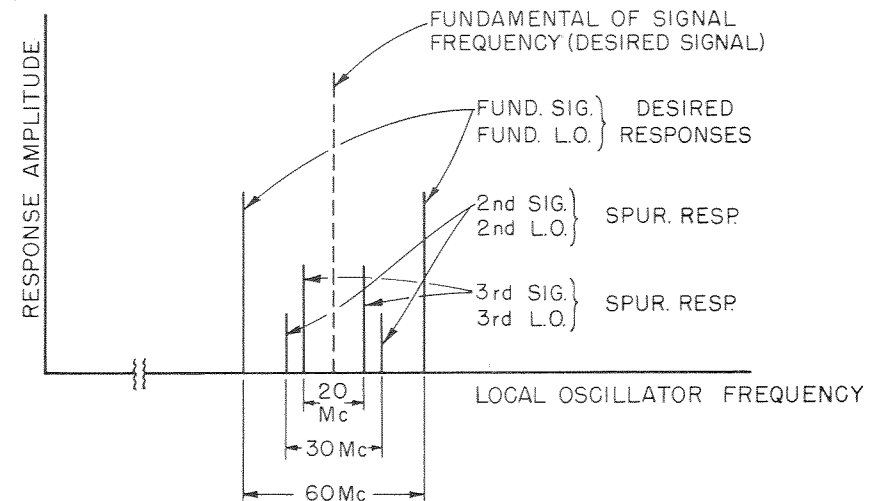

Figure 2d. Plot of responses obtained as the local oscillator frequency is varied in the vicinity of the signal frequency when the fundamental, second harmonic, and third harmonic of the signal frequency are present.

At frequencies farther from the signal frequency, other responses can be produced by the harmonics of the local oscillator frequency heterodyning with the fundamental and harmonics of the signal frequency. However, these responses are usually separated far enough from the desired response to be easily identified.

The local oscillator must be calibrated accurately enough to differentiate between the various responses, or the separation of two equal responses must be determined and the actual signal frequency corresponding to the particular pair calculated using Equation (7b). At the lower frequencies, the oscillator calibration is usually accurate enough to determine the correct response directly; however, at the higher frequencies, more care must be taken.

One method of eliminating the confusion caused by harmonic responses is to insert a Type 874-F500L 500-Mc Low-Pass Filter or a Type 874-F1000L

1000-Mc Low-Pass Filter between the generator and the admittance meter, and thus reduce the signal harmonics to a negligible magnitude.

In some cases, when an antenna is being measured and a very strong signal is being radiated in the vicinity, the antenna may pick up the spurious signal and spurious responses may be obtained in the detector. Be careful not to confuse these responses with the desired responses. The responses caused by an external signal usually can be identified by disconnecting the antenna from the admittance meter and noting which responses disappear.

For best results the mixer rectifier should be mounted directly on the detector connector of the admittance meter or through a Type 874-EL-L or other short section of air line. At some frequencies the sensitivity can be improved, if desired, by adding or removing an ell or section of air line between the detector connector and the mixer rectifier, as a better impedance match is obtained. This effect is fairly broad band and one arrangement usually gives satisfactory results over a wide frequency range.

The basic steps in tuning the local oscillator for fundamental operation are:

(1) With the detector connected to the admittance meter and the generator set to the signal frequency, set the local oscillator to the response found approximately 30 Mc above or 30 Mc below the signal frequency. (Set the MULTIPLYING FACTOR to ∞ and the CONDUCTANCE and SUSCEPTANCE indicators to 20 to maximize the fundamental response).

(2) Retune the local oscillator slightly to obtain a maximum meter indication with the AVC on. At the higher frequencies check for an equal amplitude response (30 Mc on the opposite side of the signal frequency) to insure that the response is a correct one. The separation of the two responses should be very close to 60 Mc.

(3) Throw the METER READS switch on the i-f amplifier to DC MIXER CURRENT and observe whether sufficient local oscillator voltage is being applied to the mixer crystal. The meter should indicate between 5 and 100.

If the rectified current is low and cannot be increased by adjustment of the output coupling loop of the oscillator, change the length of the line between admittance meter and mixer rectifier by the insertion or removal of a Type 874-EL-L Ell or a Type 874-L10 10-cm Air Line.

(4) Reset the METER READS switch to I-F OUTPUT. The detector is now ready for use. The meter will indicate about a 10% deflection with zero signal applied. The residual signal is caused by noise produced in the mixer and first i-f stage. If the local oscillator voltage applied across the mixer crystal is excessive, the residual signal may be much larger.

Modern communications receivers having broad-band i-f circuits are suitable for use with the Type 874-MR Mixer Rectifier. The bandwidth of the re-

ceiver should be at least 20 kc to prevent drifting of the two high-frequency oscillators used from being excessively annoying.

2.2 R-F LEAKAGE

2.21 SOURCES OF LEAKAGE:

At high frequencies, the reactance of even very short leads is high and hence, in order to minimize difficulties resulting from leakage, all connections between the generator and the admittance meter and the detector and the admittance meter must be completely coaxial. Of course, a well-shielded generator and detector should also be used. Leakage from the generator to the detector, from the generator to the circuit under test, or from the circuits under test can cause errors. In cases in which the detector shielding is much poorer than that of the generator, leakage difficulties resulting when a radiating circuit is measured can sometimes be eliminated by reversing the generator and detector connections.

Leakage can also be caused by loose joints in the coaxial system. For instance, if coaxial panel connectors are not securely fastened to their respective panels or chassis, or if the coupling nuts on any of the Type 874 Connectors that fasten the outer contacting members to the shell are loose, leakage voltages can be developed across these joints. The coupling nut on the Type 874 Connector is a $\frac{1}{4}$ -inch threaded ring at the base of the connector, and has GENERAL RADIO CO. Type 874 stamped on it. On the Type 874-R22 Coaxial Cable the coupling nut is just under the large end of the rubber sleeve. The rubber sleeve can be folded back to expose the coupling nut.

Leakage from a-c power cords can have effects similar to those mentioned above. At the lower frequencies power circuits can be by-passed rather easily through the use of low-inductance mica or ceramic capacitors connected from either side of the a-c line to ground at the point of entry into the chassis.

2.22 LEAKAGE CHECKS:

Leakage can be checked as follows:

(1) Hand-capacity effects, that is, a shift in the null caused by moving one's hand near or touching various parts of the instrument, indicate the presence of leakage. The effects should not be confused with actual changes in the measured admittance which sometimes result under these conditions when a radiating system is measured.

(2) Remove the center conductor from a Type 874-L10 10-cm Air Line. Obtain a balance with the circuit under test connected. Then disconnect the line from the detector and insert the modified Type 874-L10 Air Line between the

instrument and the line.⁹ If the detector still indicates zero signal, the detector leakage is negligible. It may be necessary to retune the detector slightly when the tube is inserted. If the meter deflection increases, make sure it is not a result of increased noise produced by the mixer with the increase in local oscillator voltage produced across the crystal when the input circuit is open circuited. Turn off the oscillator driving the admittance meter to check whether the deflection is caused by leakage or by noise. The effect of any leakage on the measurement accuracy can be estimated from the unbalance required to produce a meter deflection equal to the leakage signal.

(3) Repeat the procedure outlined in (2) with the generator connections. In this case, the generator frequency may be shifted slightly due to the change in load impedance and the generator may have to be retuned.

(4) Measure the admittance of the unknown with the generator and detector connected in their normal positions. Then reverse the generator and detector connections and remeasure the admittance. If no significant leakage is present in either measurement, the measured admittance will be the same in both cases.

⁹In most cases a satisfactory check can be made by withdrawing the detector connector until the center conductor loses contact with the conductor on the instrument. The outer conductors should still remain in contact. The use of this method eliminates the need for a special piece of line. Remember that the meter indication on many detectors may not be zero with zero applied signal because a residual deflection is produced by noise generated in the mixer and first i-f stage.

NOTE

The Type 1602-B Admittance Meter employs Type 874-BL Locking Coaxial Connectors. These connectors can be used interchangeably with the standard Type 874 Connectors. When mated with another locking connector, a firm mechanical coupling of the two is achieved when the coupling shell is engaged. The shielding is also improved significantly, and, in general, the leakage is reduced by at least 50 db.

The "quick-disconnect" feature of the standard Type 874 Coaxial Connectors is retained in the locking type if the coupling shell is not engaged. However, in this case the shielding is not as effective.

2.3 MEASUREMENTS ON COAXIAL CIRCUITS HAVING A 50-OHM CHARACTERISTIC IMPEDANCE

2.31 ADMITTANCE MEASUREMENTS:

2.311 Method: The conductive and susceptive components of the admittance of a circuit employing coaxial lines having a 50-ohm characteristic impedance can be measured directly. A suitable generator and detector are first connected as outlined in Paragraph 2.1. For the most accurate results an unmodulated signal should be used, as in some measurements the frequency modulation resulting from amplitude modulation of the oscillator, and amplitude modulation sidebands, can cause errors. The meter on the Type 1216-A I-F Amplifier, or the S meter indication on communication receivers, can be used to indicate the output for an unmodulated signal. Remember that a zero signal input will not always mean a zero meter deflection because of residual meter deflections caused by noise.

First plug the Type 1602-P4 50-ohm Termination Unit into the connector adjacent to the G_s engraved on the rear of the junction block at the base of the generator connector. Then insert the Type 1602-P1 or Type 1602-P3 Calibrated Susceptance Standard in the connector adjacent to the engraved B_s and set to the operating frequency.¹⁰ Make sure that the connector is pushed in all the way. The choice of standard depends on the frequency at which measurements are to be made. The Type 1602-P1 Stub is calibrated for frequencies between 150 and 1000 Mc and the Type 1602-P3 Variable Air Capacitor is calibrated for frequencies between 41 and 150 Mc. Note the two different colored scales on the standards. When the white scale is used the sign of the measured susceptance on the dial is as indicated by the engraved white + and - signs. When the orange scale is used on either the Type 1602-P1 Stub or the Type 1602-P3 Variable Air Capacitor the sign of the measured susceptance is as indicated by the orange + and - signs. Note that the signs are opposite for the orange and white scales. Over the white range, the stub is set to one-eighth wavelength where the standard susceptance is negative. Over the orange range the stub is set to three-eighths wavelength where the standard susceptance is positive, thus causing a reversal in sign of the susceptance scale.¹¹

If the circuit under test is fitted with a Type 874 Coaxial Connector, it can then be plugged directly into the connector adjacent to the Y_x engraved at the base of the GENERATOR connector. If the unknown circuit is fitted with another type of connector, use one of the adaptors listed in Paragraph 1.3.

¹⁰If the frequency is not accurately known, the susceptance standard can be accurately set as outlined in Paragraph 3.1.

¹¹If the frequency is above 1000 Mc, set the stubs as outlined in Paragraph 2.9.

After the circuit to be measured is connected, set the MULTIPLYING FACTOR indicator at 2 and adjust the CONDUCTANCE and SUSCEPTANCE controls until a balance is obtained. (Remember that a residual meter deflection may be produced by noise). If the balance appears to be beyond the range of either control, increase the MULTIPLYING FACTOR setting and readjust the controls. Keep increasing the MULTIPLYING FACTOR until a balance is obtained.¹² If in the original balance, both the conductance and susceptance dial readings are less than 3/4 of full scale, greater accuracy can be obtained by setting the MULTIPLYING FACTOR indicator to a lower multiplier. In all cases the greatest accuracy can be obtained by using the lowest MULTIPLYING FACTOR possible. The measured conductance is the CONDUCTANCE scale reading multiplied by the reading of the MULTIPLYING FACTOR scale. The measured susceptance is the SUSCEPTANCE scale reading multiplied by the reading of the MULTIPLYING FACTOR scale. The sign of the susceptance is determined from the quadrant in which the balance occurs. The sign of each quadrant is dependent on the scale used on the Type 1602 Susceptance Standard. The signs are found on either side of the word SUSCEPTANCE engraved on the dial. The white + and - signs correspond to the white scales on the stub while the orange + and - signs correspond to the orange scale on the Type 1602-P1 Stub and Type 1602-P3 Capacitor.

If it is not possible to balance down to the noise level, the residual indication may be produced by harmonics of the r-f signal. In this case insert an appropriate Type 874-F Low-Pass Filter between the meter and detector.

2.312 Line Length Corrections for Admittance Measurements: The Type 1602-B U-H-F Admittance Meter actually measures the admittance at a point inside the junction block directly under the center of the loop coupling to the unknown line. Therefore, if the admittance or impedance is desired at the actual point of connection to the unknown line or at any other point along the unknown line, the effect of the electrical length of the line between the two points in question must be corrected for. If the standing-wave ratio alone is desired, it can be calculated directly from the admittance measurements as outlined in Paragraph 2.33, as it is independent of the length of line, or measured directly as outlined in Paragraph 2.332.

The effect of the length of transmission line on the admittance can be corrected for using transmission-line equations, as outlined in Paragraph 2.3124, or the Smith Chart, a graphical form of the transmission-line equations, which is described in Paragraph 2.3123. The line-length correction can be eliminated for most measurements if the Type 874-LK Constant-Impedance Adjustable Line is used as described in the following paragraph. This method is recommended for all but the most accurate measurements as it is

¹² For the greatest accuracy, the MULTIPLYING FACTOR arm should always be set to a calibrated point on the scale.

very simple and the unknown admittance or impedance can be read directly from the scales.

If the electrical length of line between the measuring point and the point at which the admittance is desired is exactly half a wavelength, or an integer multiple thereof, the measured admittance will be the same as the admittance of the unknown, provided the half-wave section has a uniform characteristic impedance and negligible losses. If the line length is an odd multiple of a quarter wavelength, the admittance meter will read the resistive and reactive components of the unknown impedance. The Type 874-LK20 Constant-Impedance Adjustable Line can be used to adjust the over-all length to either of these values and thus eliminate the need for line corrections in many cases.

2.3121 Use of the Type 874-LK20 Constant-Impedance Adjustable Line to Eliminate Line-Length Corrections: As previously mentioned, if the over-all electrical line length is an integer multiple of a half wavelength, the line is uniform, and the losses are negligible, the unknown admittance is the same as the measured admittance. The line length can be adjusted to the half-wavelength value by means of a Type 874-LK20 Constant-Impedance Adjustable Line inserted between the admittance meter and the unknown line. For this adjustment the line is short- or open-circuited at the point at which the admittance is desired as described in Paragraph 2.3127, the admittance meter set to balance at the admittance corresponding to a short circuit if the line is short-circuited or to an open circuit if the line is open-circuited, and the instrument balanced by adjusting the constant-impedance line.¹³ It may be necessary to adjust the conductance arm on the instrument slightly to obtain a perfect null to compensate for small losses and errors. The short or open circuit is then removed and the circuit to be measured connected.

The admittance of a short circuit is $Y_{sc} = \infty + j0$ for the zero loss case. However, in the practical case, the conductance is not infinite but is very large compared to the characteristic admittance. Since it is difficult to obtain good accuracy with the admittance meter when measuring very large conductances, an open-circuit setting is much to be preferred over a short-circuit setting. The admittance of an open circuit is $Y_{oc} = 0 + j0$ which can be measured with good accuracy using the admittance meter. The open-circuit setting is, therefore, generally used.

For maximum accuracy, impedances whose magnitudes are large compared to 50 ohms should be measured using a half-wave line, and impedances whose magnitudes are small compared to 50 ohms should be measured using a quar-

¹³ The insertion of a Type 874-G10 10 db Pad between the generator and admittance is recommended if a tightly coupled oscillator is used to prevent difficulties which can arise from frequency pulling and loading of the oscillator as the adjustable line is varied. No pad is necessary if a signal generator is used as the driving source. Omit pad if sensitivity is too low.

ter-wave line. For impedances in the vicinity of 50 ohms, roughly the same accuracy can be obtained using either length of line.

The usual procedure for measuring the admittance is as follows:

(1) Connect the Type 874-LK Adjustable Line to the unknown connector, Y_x , on the admittance meter.

(2) Open circuit the line using a Type 874-WO3 Open Circuit Termination Unit or other open-circuit unit producing an open circuit at the point at which the admittance is desired. (See Paragraph 2.3127). If the connection between the unknown and the measuring instrument is made by means of a length of 50 ohm cable, keep the cable in the circuit when making the open circuit and adjusting the over-all line length to a half wave-length unless the cable is part of the circuit under test and the admittance at its input end is desired. (The use of cable should be avoided if possible if the maximum accuracy is desired as the tolerances on the characteristic impedance of cables are wide and the characteristic impedance is generally not uniform along the cable).

(3) Set the CONDUCTANCE and SUSCEPTANCE indicators to zero, the MULTIPLYING FACTOR to unity, and adjust the line length until a null is obtained. If the proper setting is beyond the adjustment range of the line, add sections of Type 874-L20 Air Line until the proper setting can be obtained. It may be necessary to adjust the CONDUCTANCE arm slightly to obtain a complete null as small losses and errors produce small conductance readings. When the proper line adjustment is found, lock the adjustable line.

(4) Disconnect the open circuit, connect the unknown, and balance the admittance meter by means of the CONDUCTANCE, SUSCEPTANCE, and MULTIPLYING FACTOR arms. The conductance of the unknown is the reading of the CONDUCTANCE scale multiplied by the MULTIPLYING FACTOR. The susceptance of the unknown is the reading of the SUSCEPTANCE scale multiplied by the MULTIPLYING FACTOR.

(5) If a cable having an appreciable loss is used to make the connection between the unknown and the instrument, the measured admittance can be corrected for the effect of the cable loss as outlined in Paragraph 2.3126.

At frequencies below 680 Mc, the 22-cm extension range of the adjustable line is less than a half wavelength and in some cases it will not be possible to shorten or extend the line sufficiently to obtain an over-all half-wavelength line. In these cases sections of Type 874-L20 Air Line can be added to increase the length or the line can be adjusted to an effective length of a quarter wavelength and impedance rather than admittance measured as described in the following paragraph. If either admittance or impedance is measured, measurements at frequencies as low as 340 Mc can be made in all cases without adding sections of line.

The small discontinuities present in the adjustable line cause the measurement accuracy to be somewhat poorer than is obtainable when no adjustable line is used and line-length corrections are made. The error present is a function of the frequency and the unknown admittance. The maximum possible error is proportional to the VSWR of the adjustable line, which in turn is approximately proportional to frequency. The VSWR of the adjustable line is less than 1.04 at 1000 Mc. The maximum possible error is a minimum when the unknown is matched to the line, that is $Y_x = 20 + j0$ millimhos and increases as the VSWR on the line produced by the load admittance increases.

2.31211 Example of Admittance Measurement Using a Type 874-LK Adjustable Line: If the admittance of a stub antenna located over a ground plane is desired at a frequency of 700 Mc, it can be measured in the following manner. Fit the coaxial line feeding the stub with a Type 874 Connector. The line length between the front face of the bead in the connector and the base of the stub is made exactly 3 cm as outlined in Paragraph 2.3127.

In this case it is possible to connect the adjustable line and admittance meter directly to this connector and no auxiliary cable is required. The Type 874-WO3 Open-Circuit Termination Unit is then connected to the end of the adjustable line to simulate an open circuit at the antenna, the conductance and susceptance indicators set at zero, and the adjustable line adjusted until the minimum detector indication is obtained. The conductance arm is adjusted slightly to obtain a perfect null. The adjustable line is then locked.

The open circuit is removed, the antenna connected, and the admittance meter balanced. The scale readings are as follows:

$$G = 15.0 \text{ millimhos}$$

$$B = +3.0 \text{ millimhos}$$

$$M = 2$$

Therefore, the admittance of the stub antenna at 700 Mc is $30 + j 6.0$ millimhos.

If in a similar measurement the position of the antenna makes it impractical to connect the adjustable line and admittance meter directly, a length of 50 ohm cable or preferably lengths of Type 874-L30 Air Line would be used to make the connection. The auxiliary line or cable would then be treated as part of the adjustable line.

If the antenna under test is normally fitted with a length of cable and the admittance seen looking into the cable is desired, the admittance at the face of insulating bead in the Type 874 Connector on the end of the cable can be measured in the following manner. Connect a Type 874-WO Open-Circuit Termination Unit to the adjustable line, which effectively places an open circuit at the front face of the bead in the cable. Then adjust the adjustable line as described above until the effective line length is a half wavelength.

Then remove it and connect the cable for the actual measurement in the usual manner.

As previously pointed out, the open circuit must be made at the point at which the admittance is desired. In many applications, methods other than those outlined above will be more practical for open circuiting the line in order to adjust it to the proper length. If necessary, differences in the position of the open circuit and the point at which the admittance is desired can be compensated for by changing the length of the adjustable line an amount equal to the electrical length of line between the two points in question.

2.3122 Measurement of Impedance Using the Type 874-LK Constant-Impedance Adjustable Line: If the over-all effective line length is set to an odd integer multiple of a quarter wavelength, the admittance seen by the admittance meter, Y_m , is

$$Y_m = \frac{Y_o^2}{Y_x} \quad (8a)$$

or

$$Y_m = Y_o^2 Z_x \quad (8b)$$

$$R_x = \frac{G_m(\text{mhos})}{Y_o^2} = 2.5 G_m(\text{millimhos}) \text{ ohms} \quad (9)$$

$$X_x = \frac{B_m(\text{mhos})}{Y_o^2} = 2.5 B_m(\text{millimhos}) \text{ ohms} \quad (10)$$

Therefore, the readings of the conductance and susceptance dials multiplied by 2.5 are the series resistance and reactance of the unknown. This impedance measurement property of the combination of the admittance meter and the adjustable line is very useful.

The over-all line length is set to an effective quarter wavelength by short-circuiting the line at the point at which the impedance is desired as outlined in Paragraph 2.3127, setting the admittance meter to balance at an open circuit ($0 + j0$) and adjusting the line length until a balance is obtained.

The procedure for measuring the impedance of coaxial circuits is the same as that used for measuring the admittance as described in Paragraph 2.3121 except that the line is terminated in a short circuit rather than an open circuit when the line is adjusted to the proper length.

2.31221 Example of Impedance Measurement Using a Type 874-LK Adjustable Line: If the impedance of the stub antenna described in Paragraph 2.31211 is measured at a frequency of 700 Mc, the connections and setup are similar to those used for the admittance measurement except that a Type 874-WN3 Short-Circuit Termination Unit is used in place of the open circuit termination. The scale readings obtained are:

$$\begin{aligned} G &= 12.8 \text{ millimhos} \\ B &= -2.6 \text{ millimhos} \\ M &= 1 \end{aligned}$$

and the corresponding resistance and reactance are:

$$\begin{aligned} R &= 2.5 \times M \times G = 32.0 \text{ ohms} \\ X &= 2.5 \times M \times B = -6.4 \text{ ohms} \end{aligned}$$

2.3123 Line-Length Correction Using the Smith Chart: Correction for the length of line between the point at which the instrument measures the admittance and the point at which the measurement is desired can be easily made through the use of the Smith Chart, a copy of which is shown in Figure 3. The chart shown is drawn for a system having a characteristic admittance of 20 millimhos (50 ohm impedance). Other charts are available in a normalized form in which the components are normalized with respect to the characteristic impedance of the line. A slide-rule version of the normalized chart is available from the Emeloid Corporation, Hillside, New Jersey. (See the Specifications at the front of this instruction book for a list of the various forms of Smith charts available from General Radio).

Corrections for the line length are made as follows:

- (1) Find the point on the chart corresponding to the measured conductance and susceptance.
- (2) Draw a line through this point and the center of the chart. The line should extend to intersect the WAVELENGTHS TOWARD LOAD scale on the outer edge of the chart as shown in Figure 3.
- (3) Determine the reading of the WAVELENGTHS TOWARD LOAD scale at its intersection with the straight line drawn.
- (4) Add the effective electrical length in wavelengths of the line to be corrected for to the scale reading and find the point on the scale corresponding to the sum.
- (5) Draw a radial line from the point found in Step 4 to the center of the chart.
- (6) Measure the distance from the center of the chart to the point plotted in Step 1 and lay off an equal distance from the center of the chart along the line drawn in Step 5.
- (7) Determine the coordinates of the point found. They are the conductance and susceptance of the unknown.

The radial distance from the center of the chart to the points corresponding to the measured admittance and the unknown admittance is a function of the standing-wave ratio. The VSWR corresponding to a certain distance can be determined from the scale located at the lower left corner of the figure.

If the impedance rather than the admittance of the unknown is desired,

ADMITTANCE COORDINATES—20-MILLIMHO CHARACTERISTIC ADMITTANCE

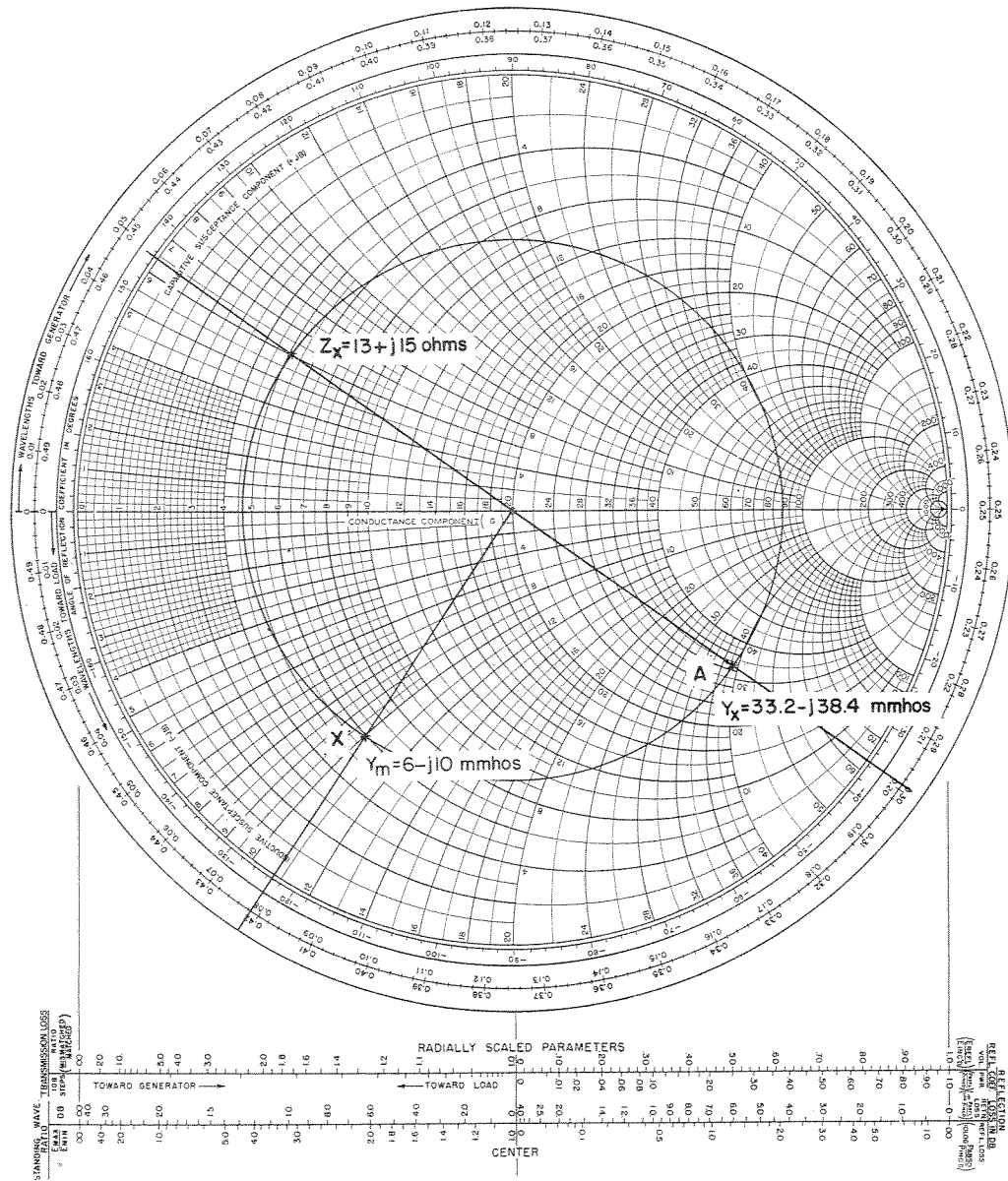

Figure 3. An example of the use of the Smith Chart to calculate the unknown admittance or impedance when the measured admittance is $6 - j10$ millimhos and the line length, 0.1225 wavelength.

use the same method as outlined above but add 0.25 to the line length used and multiply the coordinates of the point found by 2.5. The result is resistance and reactance of the unknown impedance.

For example if the measured admittance is $6 - j10$ millimhos and the electrical length of line between the point at which the admittance is desired and the point at which the instrument measures the admittance is 0.1225 wavelengths, the calculation can be carried out as shown on Figure 3. The point X corresponds to the measured admittance, and the line drawn through this point and the center of the circle intersects the WAVELENGTHS TOWARD LOAD scale at 0.0785. The second line is then drawn through the center of of the circle and the point $0.0785 + 0.1225 = 0.2010$ on the WAVELENGTHS TOWARD LOAD scale. The coordinates of the point, A, the same radial distance from the center of the circle are $33.2 - j38.4$ millimhos, the components of the unknown admittance, If the impedance is desired, the addition of 0.25 to the line length results in a WAVELENGTHS TOWARD LOAD scale setting of 0.4508 and the resultant point has coordinates of $5.2 + j6$ corresponding to an impedance of $13 + j15$ ohms as shown in Figure 3.

2.3124 Line-Length Corrections Using Transmission-Line Equations: A more tedious, but more accurate method of correcting for line length is through the use of transmission-line equations. The admittance, Y_x , at a point a distance l wavelengths from the point at which admittance, Y_m , is measured can be calculated from the equation

$$Y_x = Y_o \times \frac{Y_m - jY_o \tan 2\pi l}{Y_o - jY_m \tan 2\pi l} \quad (11)$$

or

$$Z_x = \frac{1}{Y_o} \times \frac{Y_o - jY_m \tan 2\pi l}{Y_m - jY_o \tan 2\pi l} \times 10^3 \text{ ohms} \quad (12)$$

assuming the line is lossless. All admittances are in millimhos.

2.3125 Determination of Electrical Length of Line: In the general case the electrical length of line between the point at which the impedance or admittance is desired and the point at which it is measured by the instrument can be determined by short- or open-circuiting the line at the point at which the measurement is desired and measuring the susceptance, B_{sc} or B_{oc} .¹⁴

¹⁴ In the open-circuit case, the fringing capacitance at the end of the center conductor will lead to errors unless compensated for. In the short-circuit case inductance in the short-circuiting strap or sheet will cause similar errors but they can be made small if the short circuit approximates a disk termination. Hence, in the general case the short-circuit method is preferred. However, the Type 874-WO and WO-3 Open-Circuit Terminations are compensated for fringing capacitance and hence can be used.

The electrical length for the short-circuit case can be determined by plotting the susceptance on a Smith Chart,¹⁵ drawing a line which intersects the WAVELENGTHS TOWARD LOAD SCALE through the point and the center of the chart, and measuring the distance in wavelengths along this scale in a counter-clockwise direction to the 0.25 wavelength point. This difference is equal to the electrical line length minus an integer number of half wavelengths. The half wavelength sections of line omitted have no effect on the measurements if the line is uniform and the losses negligible. The same procedure holds for the open-circuit case, except the distance to the 0 point on the scale is determined.

For maximum accuracy use the open circuit to determine line length when the unknown admittance is less than 20 millimhos, and the short circuit when the unknown admittance is greater than 20 millimhos.

For example, if the measured short-circuit susceptance is + 40 millimhos, the electrical line length is $0.500 - 0.3237 + 0.25 = 0.4262$ wavelengths + $\frac{n}{2}$ as shown in Figure 4.

The electrical line length, l_e , can also be calculated from one of the following equations, where n is an integer.

for the short-circuit case

$$l_e = \frac{1}{360} \cot^{-1} \left(-\frac{B_{sc}}{Y_0} \right) + \frac{n}{2} \text{ wavelengths} \quad (13)$$

for the open-circuit case

$$l_e = \frac{1}{360} \tan^{-1} \left(\frac{B_{oc}}{Y_0} \right) + \frac{n}{2} \text{ wavelengths} \quad (14)$$

If the effective line length is measured at the same frequency the unknown is measured at, the $\frac{n}{2}$ term is of no importance as previously mentioned. However, if measurements are to be made at many frequencies, it may be desirable to measure the line length at only a few frequencies and determine a factor from which the line length at all other frequencies can be determined by multiplying the factor by the frequency. To do this the over-all line length including the number of half-wavelength sections must be determined and divided by the frequency of measurement to determine the proportionality factor, K. Integer multiples of 0.5 wavelength should be added to the measured effective length at each frequency until the same K factor is obtained for all frequencies. Ambiguity can be avoided by estimating the electrical line length. The electrical line length is equal to the physical length multiplied by the square root of the effective dielectric constant of the line insulation all divided by the wavelength.

$$l_e = \frac{l_p \sqrt{K}}{\lambda} \text{ wavelengths where } l_p \text{ is the physical line length in cm.}$$

¹⁵See Paragraph 2.3123.

ADMITTANCE COORDINATES—20-MILLIMHO CHARACTERISTIC ADMITTANCE

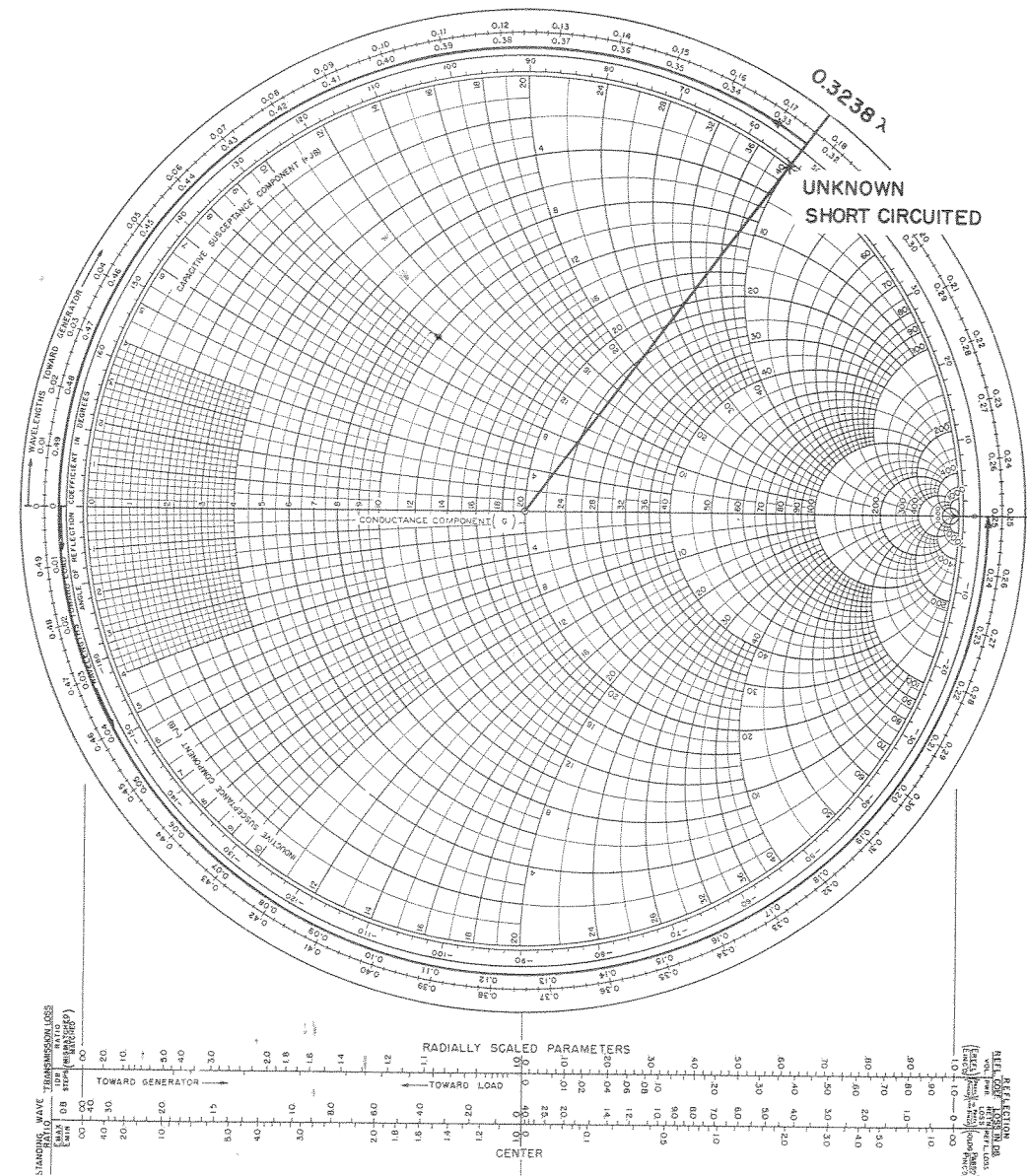

Figure 4. Use of the Smith Chart to determine the electrical length of a line from the admittance measured with the unknown short-circuited.

When this method is used for reasonably long lines, the frequency must be known very accurately.

As an example, assume that the effective electrical length of a polyethylene cable approximately 5 meters long is measured, and the following results are obtained.

Frequency, Mc	Effective Electrical Length
f	l_e , wavelengths - $\frac{n}{2}$
325 Mc =	0.140
475 Mc =	0.380
590 Mc =	0.250

Time can be saved and ambiguity avoided by estimating the effective electrical length for each frequency from the physical length and the dielectric constant and choosing the integer multiple of 1/2 which when added to the measured electrical length is the closest to the estimated value.

Freq. Mc	Estimated l_e	Measured $l_e + \frac{n}{2}$	n	$K = \frac{l_e}{f_{mc}}$
325	8.19	8.14	16	.0250
475	11.93	11.880	23	.0249
590	14.88	14.750	29	.0251

The calculated value of K will usually not be exactly the same for all the measurements due to various errors, and the average value should be chosen as the most accurate.

$$l_e = K f_{mc} \text{ wavelengths} \quad (15)$$

2.3126 Effect of Line Loss on Line-Length Corrections: Loss in any line or cable used to connect the unknown to the admittance meter tends to reduce the VSWR and hence has an effect on the impedance or admittance. Correction for line-loss can be made using the Smith Chart.

2.31261 Measurement of Line Loss: The magnitude of the loss can be determined by measuring the input conductance when the line is resonant with its far end open- or short-circuited. The best accuracy is obtained when the low-admittance resonant condition is used. At resonance, the input susceptance will be zero and the input conductance will be G_1 . The loss can be determined by plotting G_1 in the Smith Chart, measuring the distance from G_1 to the center of the chart, and laying off an equal distance along the TRANSMISSION LOSS scale located at the bottom of the chart. The number of db steps from the left hand end of the scale to the point located is the loss in the line.

In an actual measurement, it is usually not practical to change the line length to obtain the resonant condition and hence the frequency is usually changed until the measured susceptance is zero. Since the attenuation usually varies as the square-root of frequency at low frequencies and linearly with frequency at very high frequencies, a small error may result by measuring the loss at a frequency slightly different from the frequency at which the unknown impedance is measured. If the error is significant, more accurate results can be obtained by measuring the loss at several frequencies on either side of the desired frequency and plotting the results. The loss at the desired frequency can then be found from the graph. This method is also useful when a series of measurements are to be made over a wide band of frequencies as the loss than only has to be measured at a few frequencies to obtain the curve.

The steps in the usual procedure for measuring the attenuation in a length of line or cable are as follows:

(1) With the line to be measured connected to the admittance meter in the manner in which the admittance measurements are to be made, that is with the adjustable line or other devices in the circuit, disconnect the unknown and leave the line open-circuited.

(2) Measure the admittance under these conditions. If the susceptance is not zero and the conductance considerably less than 20 millimhos, change the frequency and remeasure the admittance until a frequency is reached at which the susceptance is zero and the conductance is less than 20 millimhos.

(3) Plot the measured admittance on the Smith Chart.

(4) Measure the distance from the point plotted to the center of the chart and lay off an equal distance from the center along the scale at the bottom of the chart labelled TRANSMISSION LOSS.

(5) Count the number of 1 db steps from the left hand end of the scale to the point found. This is the line loss in db. (For a more accurate scale, the REFLECTION LOSS IN DB - RET'N LOSS scale at the right side of the chart can be used if the scale readings are divided by 2).

For example if the admittance measured with the far end of a line open-circuited is $3.0 + j0$ millimhos, the loss in the line is 1.3 db.

2.31262 Correction for Line Loss: Correction for line loss can be made in the following manner using a Smith Chart.

(1) Correct for the line length assuming zero loss as outlined in Paragraph 2.312.

(2) Measure the distance from the point corresponding to the unknown admittance (calculated assuming zero losses) to the center of the chart and lay out an equal distance from the CENTER along the scale at the bottom of the chart labelled TRANSMISSION LOSS - 1 DB STEPS.

(3) Move to the left along this scale from the point located a number of db steps equal to the loss in the line and measure the distance from the new

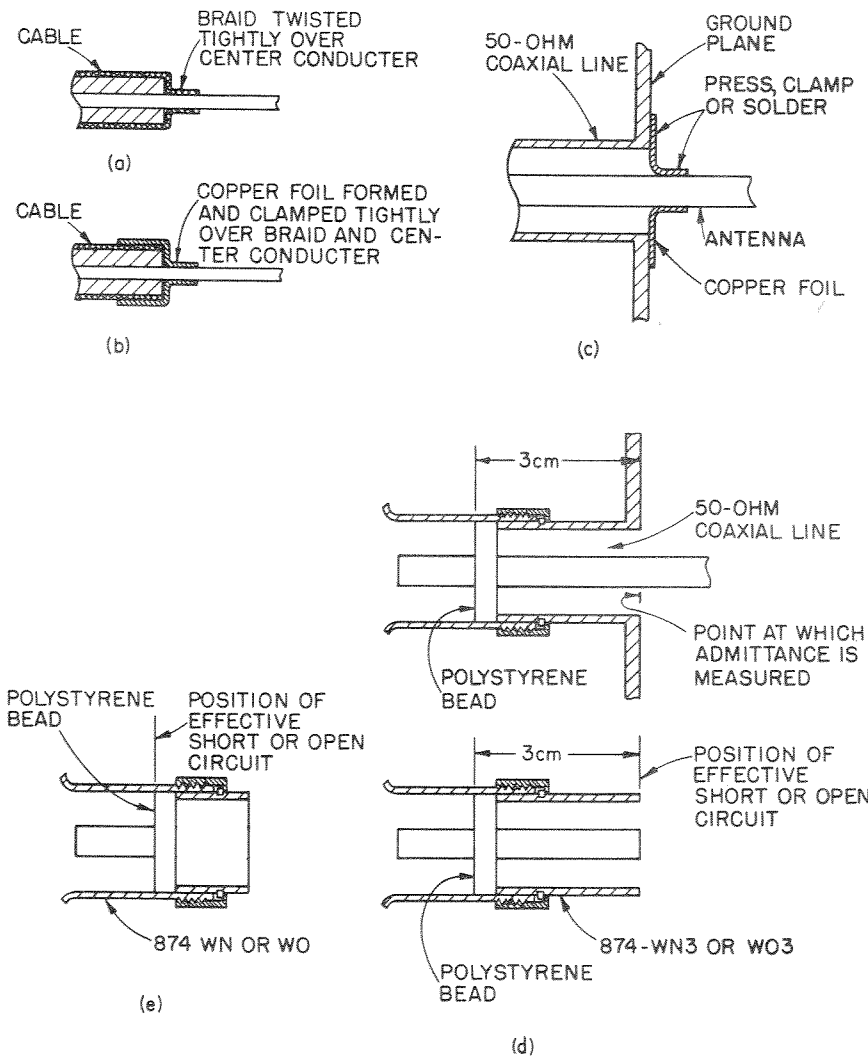

Figure 5. Methods of Short- and Open-Circuiting Cables and Air Lines.

- (a) Short-circuiting a cable with its own braid.
- (b) Short-circuiting a cable with copper foil.
- (c) Short-circuiting an air line with copper foil.
- (d) Use of Type 874-WN3 Short-Circuit Termination Unit or Type 874-WO3 Open-Circuit Termination Unit to make a short circuit or open circuit when measuring point is located 3 cm from front face of bead as in upper figure. Upper unit is similar to a Type 874-M Component Mount.
- (e) Position of the short or open circuit when a Type 874-WN Short-Circuit Termination Unit or Type 874-WO Open-Circuit Termination Unit is used.

point to the CENTER of the lower scales.

(4) Lay off an equal distance on the main chart along the line from the center to the point corresponding to the unknown admittance before correction for losses found in Step 1.

(5) The coordinates of the point found are the components of the actual unknown admittance.

For example if the unknown admittance before correction for losses is $10 + j10$ millimhos and the loss 1.3 db, the true admittance of the unknown would be $6.76 + j 11.32$ millimhos.

2.3127 Methods of Short- and Open-Circuiting a Line: The method of producing the short circuit for the line-length measurement or adjustment is important. In cases in which an antenna or other element terminating a line is being measured, the short circuit may be made by wrapping a piece of copper foil around the inner conductor and bonding it to the outer conductor of the feed line at its end as shown in Figure 5.

It is more difficult to obtain an accurate open-circuit on a line than a short-circuit as the fringing capacitance at the end of the center conductor will effectively make the line appear to be longer than it really is, and hence will cause errors unless compensated for. The fringing capacitance is compensated for in the open-circuit termination units designated below.

A more satisfactory method of producing a short circuit or open circuit is to use a Type 874-WN or WN3 Short Circuit Termination or Type 874-WO or WO3 Open-Circuit Termination Unit. The Type WN3 and WO3 units produce a short or open circuit a physical distance of 3 cm (3.2 cm electrical distance) from the front face,¹⁶ the measuring instrument side, of the insulating bead as shown in Figure 5. Hence, if the device under test is fitted with a Type 874-B Connector and a length of 50-ohm Air Line¹⁷ in which the distance between the front face of the insulating bead and the point at which the measurement is desired exactly 3 cm, the circuit under test can be disconnected and a Type 874-WN3 or Type 874-WO3 Short- or Open-Circuit Termination Unit connected for the line-length measurement. This arrangement produces very accurate results.

The Type 874-WN or -WO Termination Units produce a short or open circuit directly at the front face of the insulating bead. These units can be used even if the impedance is desired at a point on the line other than at

¹⁶The front face of the bead is located at the bottom of the slots between the contacts on the outer connector. Hence, its position can be easily determined from the outside of the connector.

¹⁷The coaxial-line section of a Type 874-M Component Mount can be used for this purpose, or a Type 874-WN3 Short Circuit or a Type 874-L10 Air Line can be modified to be suitable.

the face of the bead if the electrical distance between the two points is added to or subtracted from the line length measured with the short or open circuit termination units connected. The electrical line length for air dielectric line is equal to the physical length divided by the wavelength. Each bead in the Type 874 Connector effectively adds 0.20 cm to the length in addition to its physical length.

2.32 ADMITTANCE TO IMPEDANCE CONVERSION USING SMITH CHART:

The admittance components measured by the instrument can be easily converted to impedance through the use of the Smith Chart. The complex impedance of any admittance plotted in the chart is located at the same radius from the center of the chart and 180 mechanical degrees (0.25 wavelengths) around. If the admittance chart shown in Figure 3 is used, the components of the 180° point must be multiplied by 2.5 to obtain the resistance and reactance. If the chart is normalized, the normalized values must be multiplied by the characteristic impedance to obtain the components of the unknown impedance.

2.321 MEASUREMENT OF RESISTIVE COMPONENT OF HIGH-Q ELEMENT.

The resistance or conductance of many high-Q elements can be measured more accurately without resort to any of the correction equations (except line-length corrections). In this procedure a short- or open-circuited length of air line is connected to the Y_x connector and adjusted so that its reactance or susceptance is approximately equal to that of the unknown. For a first approximation the conductance or resistance of the air line can be assumed to be zero; therefore, any measured value different from zero is an error. This error should be algebraically subtracted from the conductance or resistance measured with the unknown connected. (The measured conductance value may have a negative sign.)

If a Type 874-LK20 Adjustable Line is used to eliminate line-length corrections in the usual manner, its length can be adjusted with a short- or open-circuit termination to produce the desired susceptance. If the range of adjustment is insufficient, additional lengths of Type 874-L Air Line can be added. For greatest accuracy, use a quarter-wave line length and measure impedance if the unknown impedance is high, and use a half-wave line length and measure admittance if the unknown impedance is low.

- (1) When a Type 874-LK20 set to $\lambda/4$ is used, the procedure is as follows:
 - a. Set the line to $\lambda/4$ in the usual manner and determine the settings of the conductance, susceptance, and multiplier arms, G_m , B_m , and M .
 - b. If the susceptance obtained from the product of the susceptance dial reading and multiplier is larger than 20 millimhos, substitute a Type 874-WO or -WO3 Open-Circuit Termination for the unknown and lengthen or shorten the

Type 874-LK20 and conductance arm to produce a balance at the same susceptance dial and multiplier readings. If the adjustable line cannot be made long enough, add lengths of Type 874-L Air Line until a balance is obtained. If more than a quarter-wave section of line must be added, or if it appears that the null could be obtained if the line were shortened not far beyond its range, more accurate results will be obtained if a Type 874-WN3 Short-Circuit Termination rather than a Type 874-WO3 Open-Circuit Termination is substituted for the unknown and the instrument balanced as above with the addition of sections of air line if necessary. In either case, record the conductance dial reading, G_c .

- c. Determine the effective conductance, G_e .

$$G_e = (G_m - G_c)M$$

- d. Determine the resistance and reactance of the unknown.

$$R_x = 2.5G_e$$

$$X_x = 2.5B_mM$$

(2) Procedure for same conditions as in (1) but when the impedance of the unknown is small compared to 50 ohms. (Greater accuracy can be obtained in this case by use of a $\lambda/2$ line as in (3).)

- a. Connect a Type 874-WN3 Short-Circuit Termination in place of the unknown, set CONDUCTANCE arm and SUSCEPTANCE arms to zero, MULTIPLIER to 1 and balance by adjusting line.
- b. Same as (1) but replace 874-WO3 with 874-WN3 and vice versa.
- c. Same as (1).

(3) When a Type 874-LK20 Adjustable Line set to $\lambda/2$ is used to measure an unknown whose impedance is small compared to 50 ohms ($Y_x > 20\text{mmhos}$), the procedure is as follows:

All steps same as in (1) except that 874-WO3 is replaced by 874-WN3 and vice versa in all steps.

(4) Procedure for same conditions as in (3) but the impedance of the unknown is large compared to 50 ohms ($Y_x < 20\text{mmhos}$).

All steps same as in (2) but with 874-WO3 replaced with 874-WN3 and vice versa in all steps.

(5) Procedure when the unknown is connected directly to instrument terminals is as follows (actual position at location of short circuit in 874-WN3):

- a. Connect unknown and measure admittance and effective line length in the usual manner. For best results, use 874-WO3 for line-length measurement if the unknown admittance is low and 874-WN3 if it is high. Obtain G_m , B_m , M and then βl .

b. Replace the unknown with a Type 874-WO3 and add lengths of 874-L10, -L20, or -L30 Air Line until a balance can be obtained with the SUSCEPTANCE indicator close to the reading obtained with the unknown connected and with the same MULTIPLIER setting. If the length of line added is more than half a wavelength, use a Type 874-WN3 Short-Circuit Termination and repeat the above procedure. Record G_c .

c. Correct the measured conductance with the unknown connected for G_c .

$$G_e = (G_m - G_c)M$$

d. Obtain the line admittance or impedance of the unknown by correcting G_e and $B_e (= B_m M)$ for the line length, as outlined in paragraphs 2.3123 and 2.3124.

If many measurements are to be made, time can be saved by the preparation of a correction chart covering all frequencies of interest. The chart must indicate which value of multiplying factor (M) is used as well as the susceptance indication.

2.33 STANDING-WAVE RATIO AND REFLECTION COEFFICIENT MEASUREMENTS

The reflection coefficient, Γ , and the standing-wave ratio, SWR, present on the line under test can be determined with the Type 1602-B U-H-F Admittance Meter by calculation from the measured admittance or by a direct voltage-ratio method.

2.331 VSWR Measurements Using the Null Method: In the null method, the actual magnitudes of the conductive and susceptive components of the admittance seen by the instrument are measured and the SWR calculated using a Smith Chart or equations. In a Smith Chart, the voltage standing-wave ratio, VSWR, is a function of the radial distance from the center of the chart to the point on the chart corresponding to the measured admittance. On the slide-rule version the rotatable arm is calibrated in VSWR and the VSWR corresponding to any admittance can be quickly determined. On the graph version, a calibration scale is provided beneath the chart from which radial distance can be converted into VSWR.

In the example of Paragraph 2.3123 the VSWR is 4.25 as shown on Figure 3.

The equation, which is more accurate but which requires more calculation, is:

$$VSWR = \frac{1 + |\Gamma|}{1 - |\Gamma|} \quad (16)$$

where $|\Gamma|$ is the magnitude of the reflection coefficient

$$|\Gamma| = \left| \frac{Y_o - Y_x}{Y_o + Y_x} \right| = \sqrt{\frac{(G_o - G_x)^2 + (B_x)^2}{(G_o + G_x)^2 + (B_x)^2}} \quad (17)$$

2.332 Direct Reflection Coefficient and VSWR Measurements:* If the Type 1602-P4 50-ohm Termination Unit is inserted in place of the susceptance standard, that is in the connector adjacent to the B_s engraved at the base of the GENERATOR connector, the conductance indicator set to zero, and the multiplying factor indicator set to 1, the ratio of the output obtained when the susceptance indicator is set to -20 (white + and - signs) to the output obtained when the susceptance indicator is set to +20 is equal to the magnitude of the reflection coefficient, Γ , and the VSWR is therefore

$$|\Gamma| = \frac{V_1}{V_2} \quad (18a)$$

$$VSWR = \frac{1 + |\Gamma|}{1 - |\Gamma|} = \frac{1 + \left| \frac{V_1}{V_2} \right|}{1 - \left| \frac{V_1}{V_2} \right|} \quad (19a)$$

if $VSWR < 1.2$

$$VSWR \approx 1 + 2|\Gamma| = 1 + 2 \left| \frac{V_1}{V_2} \right| \quad (19b)$$

(It may be necessary to shield the unused G_s connector to prevent leakage difficulties. This can be done by inserting the outer shell only of a Type 874 Connector in the connector or a Type 874-WO Open-Circuit Termination Unit. At frequencies above 1000 Mc, the unused G_s connector should be terminated in a Type 874-WN Short-Circuit Termination Unit or in a Type 1602-P4 50-ohm Termination Unit to prevent resonances in this line from causing errors.)

In this case the voltage induced in the susceptance loop is proportional to the current flowing in the terminated line and is, therefore, $-KY_o$ when the indicator is set at -20 and $+KY_o$ when the indicator is set at +20. The voltage induced in the multiplying factor loop when the indicator is set at unity is KY_L . Therefore, the total voltage, V_1 , at the detector when the susceptance indicator is set at -20 is

$$V_1 = KY_L - KY_o \quad (20)$$

and when the susceptance indicator is set at +20,

*A further discussion of this method and an additional rapid VSWR method are described in the *General Radio Experimenter*, May, 1960. Reprints are available. A second Type 1602-P4 has been furnished for use in this method.

$$\text{or } V_2 = KY_L + KY_o \quad (21)$$

$$\frac{V_1}{V_2} = \frac{Y_L - Y_o}{Y_L + Y_o} = -\Gamma \quad (22)$$

$$|\Gamma| = \left| \frac{V_1}{V_2} \right| \quad (23)$$

The Type 1216-A I-F Amplifier is very useful for this application as the voltage ratio can be accurately measured using the calibrated attenuator and meter. If the local oscillator signal applied to the Type 874-MR Mixer Rectifier is sufficiently large, the mixer will be accurately linear over almost the whole range of the attenuator. For best results, the meter should indicate at least 10% of full scale when the switch on the Type 1216-A I-F Amplifier labeled: "Meter Reads - I-F Amplifier Output - D-C Mixer Current" is set to the "D-C Mixer Current" position.

At the 0, 3 and 10 db attenuator steps, the attenuator is somewhat affected by the deviations of the input frequency from the center frequency of the amplifier. For maximum accuracy the meter indication should be peaked by adjusting the local oscillator frequency.

The steps in this measurement are as follows:

(1) Insert the Type 1602-P4 50-ohm Termination Unit in the connector marked B_s on the admittance meter and leave the connector marked G_s open-circuited. Peak the output indication by adjusting the frequency of the local oscillator.

(2) Set the CONDUCTANCE indicator to zero, the MULTIPLYING FACTOR indicator to 1, the SUSCEPTANCE indicator to -20 (white - sign), and note the output indication on the detector. With the Type 1216-A I-F Amplifier adjust the step attenuator until the meter indication is within the 0-10 db calibrated portion of the scale. Add the meter db indication and the attenuator db setting and obtain A_1 .

(3) Change the setting of the susceptance indicator to +20 (white + sign) and again note the output indication as in Step 2 and obtain A_2 . The step attenuator will probably have to be changed for this measurement.

(4) The reflection coefficient, Γ , is equal to the ratio of the output voltages corresponding to the two detector indicator settings. In the Type 1216-A I-F Amplifier this is equal to the ratio corresponding to the db difference in the db sums obtained in Steps 2 and 3. The voltage ratio corresponding to the db difference, $(A_1 - A_2)$, can be determined by using Equation (18b) or from Table 1 at the end of this manual. The db difference should always be a negative number as voltage ratio should be a number less than unity.

$$|\Gamma| = \frac{V_1}{V_2} = \text{antilog} \left(\frac{A_1 - A_2}{20} \right) \quad (18b)$$

If a non-linear detector is used, its response characteristic must be accurately known.

(5) The VSWR can be determined from Equation (19a) or (19b), or from Table 1 at the end of this manual.

2.34 IMPEDANCE MATCHING TO A 50-OHM LINE

The Type 1602-B U-H-F Admittance Meter can be used to advantage in matching a load to the 50-ohm line. For this measurement the Type 1602-P4 50-ohm Termination Unit is inserted in the connector marked G_s , the line under test inserted in the connector marked Y_x , the conductance indicator set to 20, the susceptance indicator set to zero, and the multiplying factor indicator set to 1. The susceptance stub is not required for this measurement but if it is not used, the connector, B_s , should be shielded by inserting the outer shell of a Type 874 Connector or a Type 874-WO Open-Circuit Termination Unit¹⁸ in it. If the standard stub is used, it should be set approximately to the operating frequency. The quality of the match is indicated by the magnitude of the output voltage and when a perfect match is obtained the output will be zero. The detector output therefore gives a continuous indication of the quality of the match, which simplifies the manipulation of the elements of the transformer used to obtain the desired impedance transformation.

The resultant output voltage, V , is proportional to the reflection coefficient of the unknown for small values of reflection coefficient. The actual relationship is expressed by the equation

$$|V| = K \left| \frac{\Gamma}{1 - \Gamma} \right| \quad (24)$$

2.35 ADMITTANCE OR IMPEDANCE COMPARISON

The Type 1602-B U-H-F Admittance Meter can also be used for the rapid adjustment of one coaxial-line circuit to have the same admittance or impedance as that of another or that of a standard impedance. The circuit to be used as a standard is connected to the G_s connector and the circuit to be adjusted or compared is connected to the Y_x connector. The conductance indicator is set to 20, the susceptance indicator to zero and the multiplier to

¹⁸ Above 1000 Mc, a Type 874-WN Short-Circuit Termination Unit should be used to prevent errors due to resonances in this section of line.

unity. When the two impedances are identical the detector will indicate a null. The actual output voltage, V , is proportional to the difference in the complex admittances

$$V = K (Y_x - Y_s) \quad (25)$$

where Y_s is the admittance of the standard as seen under the center of the conductance coupling loop and Y_x is the admittance of the unknown as seen under the center of unknown coupling loop.

2.36 MEASUREMENT OF IMPEDANCE MAGNITUDE DIRECTLY

The magnitude of the unknown impedance can be measured directly using a voltage-ratio method. For this measurement the Type 1602-P4 50-ohm Termination Unit is inserted in the G_s connector and the unknown inserted in the Y_x connector. The susceptance stub is not required, but if it is not connected, the outer shell of a Type 874 Connector or a Type 874-WO Open-Circuit Termination Unit should be inserted in the B_s connector to shield it to prevent radiation. If the stub is used, it should be set somewhere near the operating frequency. The susceptance indicator is set to zero, the conductance indicator to 20, and the multiplying factor to infinity, ∞ . Note the relative output voltage V_1 ; then reset the conductance indicator to zero, the multiplying factor to 1, and measure the relative output voltage V_2 . Then the magnitude of the unknown impedance as seen at a point along the unknown line directly under the loop coupling to the unknown line is:

$$\left| \frac{Z_x}{Z_0} \right| = \left| \frac{V_1}{V_2} \right| \quad \text{or} \quad |Z_x| = 50 \times \left| \frac{V_1}{V_2} \right| \quad (26)$$

2.4 T-V TRANSMITTING ANTENNA MEASUREMENTS

Impedance and VSWR measurements can be made accurately on both VHF and UHF-TV transmitting antenna systems using the admittance meter in combination with Type 874-QV2A Adaptor to 1-5/8-inch 51.5-ohm VHF Transmission Line, Type 874-QV3 Adaptor to 3-1/8-inch 51.5-ohm VHF Transmission Line, Type 874-QU1 Adaptor to 7/8-inch 50.0-ohm UHF Transmission Line, Type 874-QU2 Adaptor to 1-5/8-inch 50.0-ohm UHF Transmission Line, or Type 874-QU3 Adaptor to 3-1/8-inch 50.0-ohm UHF Transmission Line.

2.41 UHF-TV TRANSMITTING ANTENNA MEASUREMENTS

Most UHF-TV antenna systems use the new RETMA standard 3-1/8 inch 50.0-ohm transmission line. The Type 874-QU3 Adaptor provides a low-reflection transition between this line and the GR Type 874 50-ohm 5/8 inch line. (See Figure 6). For best results the admittance meter should be removed from its base and mounted on the adaptor by means of the Type 874 connector. (See Figure 7).

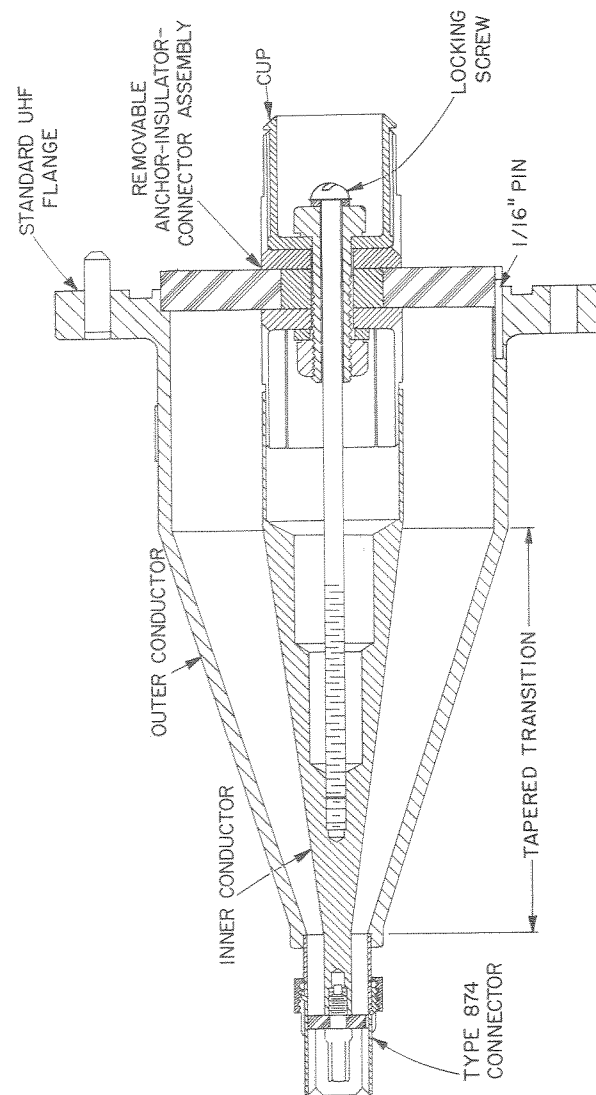

Figure 6. Cross section of Type 874-QU3A Adaptor to 50.0-ohm 3-1/8-inch rigid line.

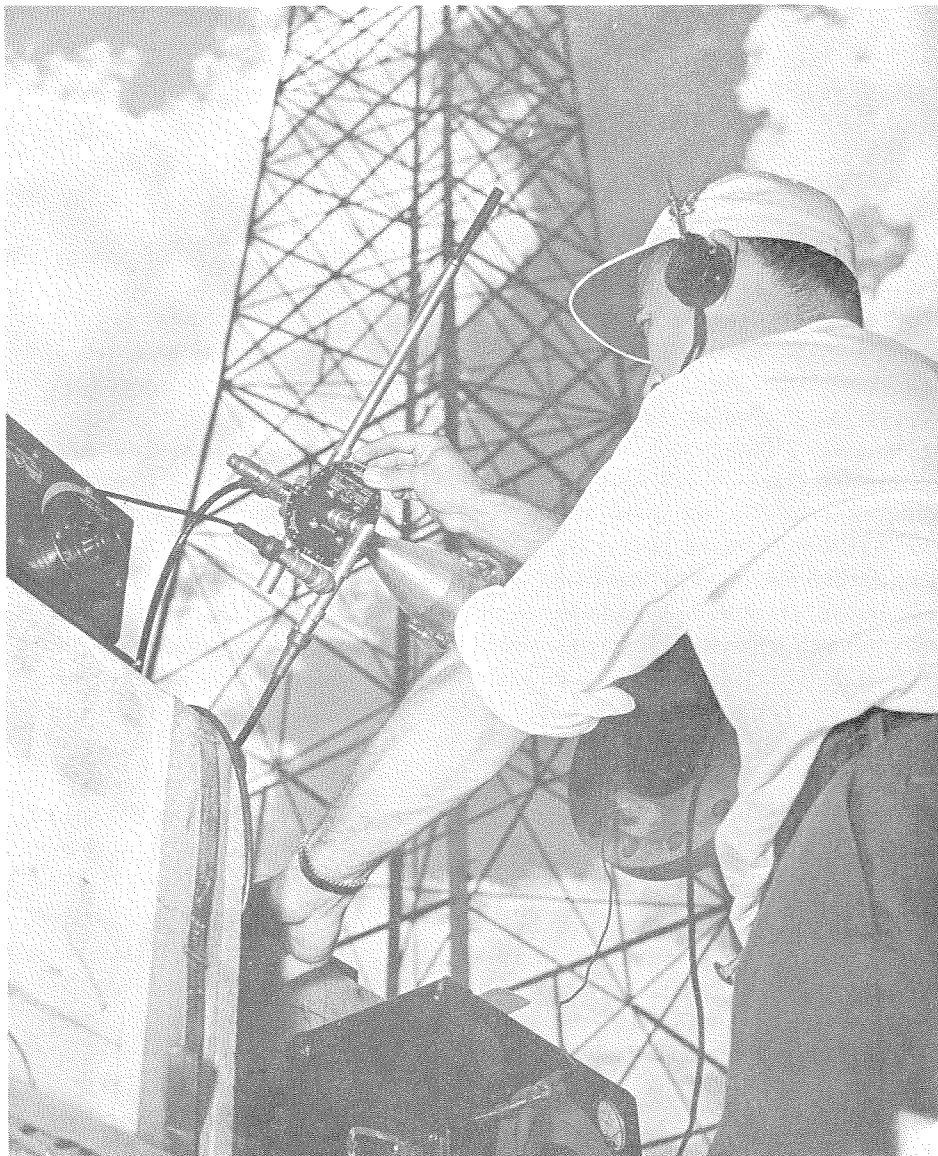

Figure 7. Measuring the standing-wave ratio on a UHF television transmitting antenna with the Type 1602-B Admittance Meter. Note that the base of the admittance meter has been removed in order to mount the instrument directly on the Type 874-QU3 Adaptor.

The most satisfactory generator for this application is a Type 1209 Unit Oscillator which is connected to the admittance meter through a Type 874-F1000 Low-Pass Filter and a Type 874-G10 10 DB Pad (the pad can be omitted if insufficient sensitivity is obtained). The Type 1021-AU UHF Signal Generator is also very satisfactory, but it is large in size and more expensive than the unit oscillator.

A detector made up of a Type 874-MR Mixer Rectifier, another Type 1209 Unit Oscillator and a Type 1216-A I-F Amplifier has proven to be very satisfactory. The unit oscillator should be tuned to the response found approximately 30 Mc from the frequency of the oscillator driving the admittance meter. (See Paragraph 2.1).

In antenna applications, two types of measurements are commonly encountered. In the first case a measurement of the overall performance of the antenna is desired, in which case the standing-wave ratio over the operating frequency band is of interest. In the second case, one is designing or compensating an antenna to match the feed line within a given accuracy. In this case, one is usually interested in the impedance or admittance at the antenna terminals or at some other point along the line.

If the line is long, both the impedance and VSWR may change very rapidly with frequency. It is sometimes necessary to use a heterodyne frequency meter in order to set the frequency accurately enough when the line is long.

2.411 VSWR Measurements: The VSWR on the antenna line can be determined from admittance measurements or from the reflection coefficient which can be measured using the voltage-ratio method.

2.4111 Voltage-Ratio Method of Determining VSWR: The voltage-ratio method of determining reflection coefficient and VSWR is the most direct as the reflection coefficient, Γ , is equal to the ratio of two output voltages which can be easily and accurately measured using the attenuator in the Type 1216-A I-F Amplifier. The VSWR can easily be determined from the reflection coefficient equation (19a) or Table 1 at the end of this manual.

$$\text{VSWR} = \frac{1 + |\Gamma|}{1 - |\Gamma|} \quad (19a)$$

If VSWR is near unity,

$$\text{VSWR} \approx 1 + 2|\Gamma| \quad (19b)$$

This measurement is made as follows:

(1) Remove the susceptance standard and in its place insert the Type 1602-P4 50-ohm Resistance Termination in the B_s connector. The G_s connector usually occupied by the conductance standard is left open.

(2) Set the CONDUCTANCE indicator to zero, the MULTIPLIER indicator to unity and the SUSCEPTANCE indicator to -20, using the white minus (-) sign.

(3) Adjust the step attenuator on the i-f amplifier until the meter reads on the calibrated portion of the DB scale.

(4) Then adjust the frequency of the local oscillator used with the mixer rectifier to obtain a maximum meter deflection. (The signal passing through the i-f amplifier should not be far off the center frequency of the amplifier or the step attenuator will not have its maximum accuracy at low attenuation settings).

(5) Record the sum, A_1 , of the step attenuator setting and the meter reading on the DB scale.

(6) Shift the SUSCEPTANCE indicator to +20 (white + sign), and adjust the step attenuator until the meter reads on the calibrated portion of the DB scale.

(7) Record the sum, A_2 , of the step attenuator setting and the meter reading on the DB scale.

(8) Calculate the reflection coefficient, Γ , from Table 1 at the end of this manual or the following equation:

$$|\Gamma| = \frac{V_1}{V_2} = \text{antilog} \left(\frac{A_1 - A_2}{20} \right) \quad (18b)$$

or VSWR

$$\text{VSWR} = \frac{1 + |\Gamma|}{1 - |\Gamma|} \approx 1 + 2|\Gamma| \text{ (if } \Gamma < 0.1\text{)}. \quad (19a)$$

For example if $A_1 = 20 + 3$ db and $A_2 = 50 + 5$ db, $|\Gamma| = \text{antilog} \left(\frac{23 - 55}{20} \right) = .025$ and VSWR = 1.05.

2.4112 Null Method of Determining VSWR: In this method the detector need not be calibrated as the admittance meter is adjusted to a null. Actually the admittance of the line is measured as described in Paragraph 2.311 and the reflection coefficient, Γ , or VSWR is calculated from the measured admittance using a Smith chart or transmission-line equations.

The steps are as follows:

(1) Set the admittance meter up with the conductance standard, susceptance standard, and unknown circuit connected in their normal positions as outlined in Paragraph 2.311.

(2) With the Type 1216-A I-F Amplifier set to AVC and the detector tuned

to the proper frequency as outlined in Paragraph 2.1, set the susceptance standard to the operating frequency and adjust the CONDUCTANCE, SUSCEPTANCE, and MULTIPLIER controls until a null is obtained (in which case the meter on the i-f amplifier reads the noise level, not zero). Tune the detector as outlined in Paragraph 2.1 and check that the DC MIXER CURRENT is at least 10% of full scale.

(3) Read the three dials. The measured conductance, G_m , is equal to the CONDUCTANCE dial reading multiplied by the MULTIPLIER setting. The measured susceptance, B_m , is the SUSCEPTANCE dial reading multiplied by the MULTIPLIER setting. The sign of the susceptance is determined from the + and - signs having the same color as the susceptance standard scale used.

(4) Plot the measured admittance on a Smith chart and determine VSWR from the distance between the center of the chart and the point plotted as outlined in Paragraph 2.331. Equation (17) can be used in place of the Smith chart if desired.

For example if the measured admittance is:

$$G_m = 19.0 \times 1 = 19.0 \text{ millimhos}$$

$$B_m = -1.0 \times 1 = -1.0 \text{ millimho}$$

the Smith chart shows the VSWR is 1.07. The equations show:

$$|\Gamma| = \sqrt{\frac{(20 - 19)^2 + (1)^2}{(20 + 19)^2 + (1)^2}} = .036$$

$$\text{and VSWR} = \frac{1 + .036}{1 - .036} = 1.074$$

2.412 Admittance Measurements: In measurements on TV transmission-line circuits, the impedance or admittance at any point along the line can be determined as outlined in Paragraph 2.31. The electrical line length to the point in question can be determined by short-circuiting the line at the point in question by means of a low-inductance copper disc or sheet. The Type 874-LK20 Constant-Impedance Adjustable Line can be used to set the over-all line length to a multiple of a quarter or a half wavelength, but the accuracy is slightly poorer than can be obtained using the direct connection as the adjustable line can have a VSWR as high as 1.04 at 1000 Mc.

2.42 VHF-TV TRANSMITTING ANTENNA MEASUREMENTS

The procedure for measuring VHF-TV antenna systems fitted with the new RETMA standard 50.0-ohm 3-1/8 inch feed line is the same as described above for UHF-TV antennas. If the antenna feed system uses the old standard 51.5-ohm 1-5/8 inch line, the Type 874-QV2A Adaptor should be used,

and if the antenna feed line is a 51.5-ohm 3-1/8 inch line, the Type 874-QV3 Adaptor should be used.

Since the admittance meter is basically designed for use with 50-ohm lines, the measurements of 51.5-ohm lines require some modification of technique. As shown in Figure 8, the 51.5-ohm characteristic is maintained in the Type 874-QV2A and 874-QV3 Adaptors to the back of the bead on the Type 874 Connector. Hence, if the admittance meter is connected directly to the connector on the adaptor without any interconnecting length of line, the total length of 50-ohm line in the circuit is only the amount present in the connector and the admittance meter, which is approximately 7 cm. At the highest VHF-TV frequency, this length of 50-ohm line introduces a VSWR in a flat line of less than 1.015 and proportionately less at lower frequencies, and hence is usually negligible.

If desired, the effect of the 50-ohm line on admittance measurements can be corrected by calculating the admittance at the start of the 51.5-ohm line from the measured admittance using the methods outlined in Paragraphs 2.3123 or 2.3124.

If the voltage-ratio method is used for determining VSWR, the susceptance arm should be set to +19.42 and -19.42 to determine two outputs rather than to + and -20 in order to obtain the reflection coefficient and VSWR present on the 51.5-ohm line. (See Paragraph 2.411). For example, if the sum of the attenuator and meter scale readings with the SUSCEPTANCE indicator set to the - side is 10 db + 3 db = 13 db = A_1 and when the SUSCEPTANCE is set to the + side the sum of the attenuator and meter scale readings is 40 db + 1 db = 41 db = A_2 . Therefore, $A_1 - A_2 = -28$ db and

$$\left| \frac{V_1}{V_2} \right| = \Gamma_{51.5} = .04 \text{ and } \text{VSWR}_{51.5} = 1.08.$$

Reflection coefficient and VSWR can also be calculated from admittance measurements using a normalized Smith chart or Equation (17) where the characteristic admittance, Y_0 , is 19.42 millimhos. (The coordinates of a normalized Smith chart are normalized with respect to Y_0 or Z_0 and hence 1.0 appears at the center of the chart).

For example, if the measured conductance, G_m , is 18.5 millimhos and the measured susceptance, B_m , is + 1.2 millimhos when a 51.5-ohm (19.42 millimhos) line is measured, the reflection coefficient on the 51.5 line is

$$|\Gamma|_{51.5} = \sqrt{\frac{(19.42 - 18.5)^2 + (1.2)^2}{(19.42 + 18.5)^2 + (1.2)^2}} = .040$$

$$\text{and } \text{VSWR}_{51.5} = \frac{1 + .040}{1 - .040} = 1.08$$

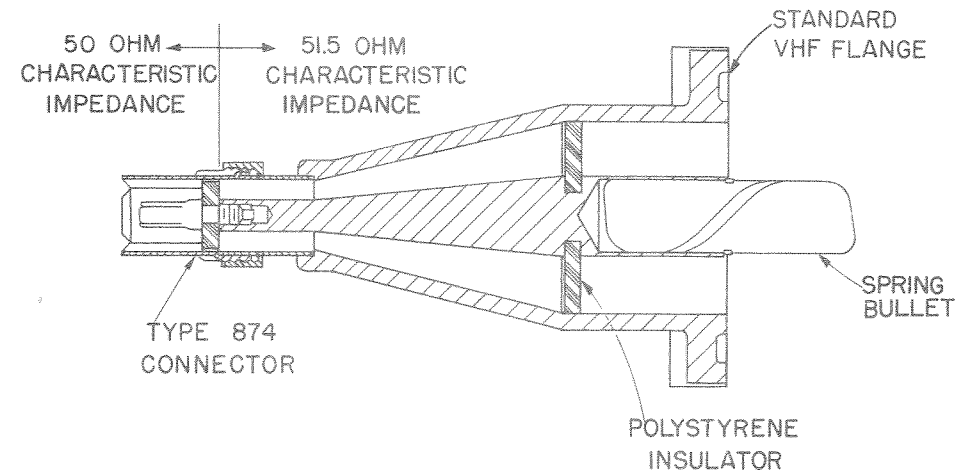

Figure 8. Cross section of the Type 874-QV2A Adaptor to 51.5-ohm, 1-5/8-inch rigid line.

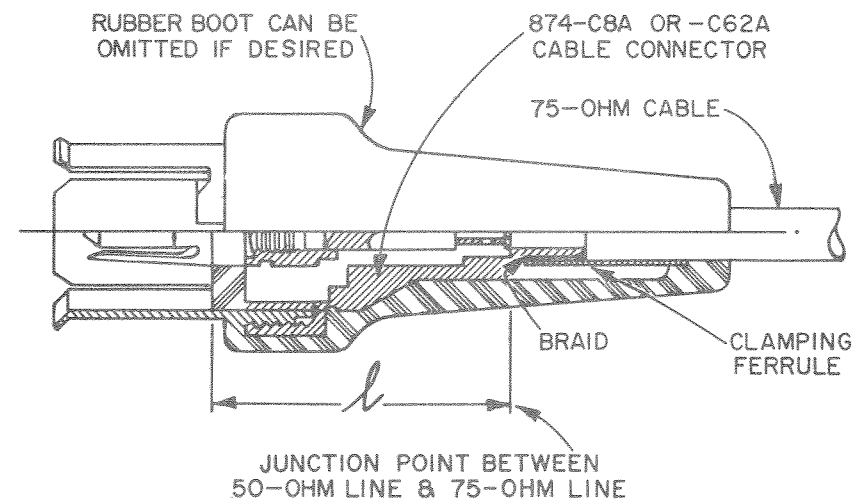

Figure 9. Sketch of a Type 874-C62 Cable Connector with a 75-ohm cable attached.

2.5 MEASUREMENTS ON LINES HAVING IMPEDANCES OTHER THAN 50 OHMS

2.51 IMPEDANCE AND ADMITTANCE MEASUREMENTS ON 72-75 OHM LINES:

Measurements on 75-ohm lines can be made by connecting the 75-ohm line to a 50-ohm line which is connected to the admittance meter, and then determining the impedance or admittance at the junction of the 50- and 75-ohm lines. One method of making the connection between 72-75-ohm coaxial cables and 50-ohm Type 874 line is to fit the 75-ohm cable with a General Radio Type 874 Connector. Type 874-C8 Cable Connectors are suitable for use with RG-11/U cable. Type 874 Connectors are 50-ohm connectors, and the junction between the 50-ohm line and the 75-ohm line is made at the point indicated in Figure 9, where the electrical length, l , is 2.6 cm (physical length 2.4 cm). There is a slight discontinuity at the junction caused by stray reactances,¹⁹ but in most applications the effect is negligible.

The effect of the section of 50-ohm line in the connectors and the admittance meter can be eliminated by adjusting the line length to a half- or quarter-wavelength by means of a Type 874-LK Constant-Impedance Adjustable Line. To obtain the proper half-wave adjustment, the 50-ohm line should be open-circuited at the 75-ohm junction, the admittance meter set to balance at zero admittance, and the line length adjusted until a null is obtained. For a quarter-wavelength adjustment, the same procedure is used except that the line is short-circuited at the junction. In the practical case, it is difficult to open-circuit or short-circuit the line exactly at the junction, but the Types 874-WO or WO-3 Open-Circuit Terminations, and 874-WN or WN-3 Short-Circuit Terminations can be used to advantage for this purpose. These units do not produce an open or short circuit exactly the desired point, but minor adjustments of the line length can be made to compensate for the difference.

In this application, the short- or open-circuit termination is connected to the end of the adjustable line and the line length adjusted as outlined above. Then, if a Type 874-WO Open-Circuit Termination or a Type 874-WN Short-Circuit Termination has been used, the adjustable line should be shortened 2.6 cm. If a Type 874-WO3 Open-Circuit Termination or a Type 874-WN3 Short-Circuit Termination has been used, the length of the adjustable line should be increased 0.6 cm.

When the termination is removed and the line under test connected, the length of 50-ohm line between the measuring point and the point at which the 75-ohm line is connected, is exactly a half- or quarter-wavelength. For

¹⁹ Whinnery, Jamison, Robbins, "Coaxial Line Discontinuities," *Proceedings of the I.R.E.*, V. 32, No. 11, p. 695, November 1944.

the half-wavelength adjustment, the admittance measured by the instrument is the admittance seen looking into the 75-ohm line at the junction. For the quarter-wavelength adjustment, the series resistive and reactive components of the input impedance to the 75-ohm line are equal to the indicated conductance and susceptance respectively, multiplied by 2.5.

An open- or short-circuit termination of the proper length can be fabricated from a Type 874-C62 Cable Connector. For the open circuit, trim off 0.15 cm of the tapered center conductor in the cable connector.

2.52 REFLECTION COEFFICIENT AND VSWR MEASUREMENTS ON 72-75-OHM LINES

The reflection coefficient and VSWR on the 72-75-ohm line can be calculated from the input admittance or impedance measured as outlined in the previous paragraph using Equation (17) or the normalized Smith chart where Y_0 and Z_0 are respectively the characteristic admittance or impedance of the line under test. (The coordinates of a normalized Smith chart are normalized with respect to a Y_0 or Z_0 and hence 1.0 appears at the center of the chart. See the Specifications at the front of this book). Reflection coefficient and hence, VSWR, can also be measured directly by a voltage-ratio method similar to that outlined for 50-ohm lines in Paragraph 2.332.

For the latter type of measurement the procedure differs slightly from the method used for 50-ohm lines in that the 72-75-ohm line under test is fitted with a Type 874 50-Ohm Connector as described in Paragraph 2.51, and connected through a Type 874-LK20 line stretcher to the connector on the admittance meter usually connected to the conductance standard. The connector usually connected to the unknown line should be left open-circuited and the MULTIPLIER set at ∞ . These connections are the reverse of those used when measuring 50-ohm lines and are necessary because the coupling to the unknown branch of the tee in the admittance meter must be adjusted to a specific amount less than unity in order to compensate for the difference in characteristic impedances, and since the CONDUCTANCE scale is more finely divided than the MULTIPLIER scale it can be set more accurately and is preferred.

The overall 50-ohm line length should then be adjusted to a quarter wavelength using the method described in Paragraph 2.51, with the exception that the CONDUCTANCE indicator is set to maximum coupling of 20, and the MULTIPLIER left at ∞ . (The susceptance standard is connected to the B_s connector and set at the operating frequency for this adjustment.

The susceptance standard is then removed and replaced by the conductance standard (Type 1602-P4), the CONDUCTANCE indicator set at $\frac{1000}{Z_0} = Y_0$, (13.33 for 74-ohm lines, 13.0 for 72-ohm lines), where Z_0 is the characteristic impedance of the line under test. The ratio of the detector voltages obtained

with the SUSCEPTANCE indicator first set to +20 and then to -20 (white + and - signs) is equal to the reflection coefficient, Γ , on the 72-75-ohm line (see Paragraph 2.332), and

$$VSWR_{75} = \frac{1 + |\Gamma|}{1 - |\Gamma|} \quad (19c)$$

Table 1 at the end of this manual can be used to convert db voltage ratios to Γ and VSWR.

2.53 MEASUREMENTS ON LINES HAVING OTHER IMPEDANCES:

If a line has a characteristic impedance other than 50 or 75 ohms, it can be measured by connecting it to a 50-ohm line using the method described in Paragraph 2.51 for a 75-ohm line or using other methods. The junction should be carefully designed and constructed to minimize errors caused by stray reactances.¹⁹

2.6 MEASUREMENTS ON BALANCED LINE CIRCUITS

Measurements on balanced line circuits can be made with the admittance meter when a Type 874-UB Balun is used to transform the balanced circuit to an unbalanced one. This balun is a flexible device which introduces only a very small error in the measurements and yet which can be used over practically the entire operating frequency range of the admittance meter. It is not a broad-band device and must be tuned to the operating frequency. A sketch of the balun appears in Figure 10.

The balun makes use of an artificial half-wave line to convert the balanced circuit to an unbalanced one. The semi-artificial line is made up of two sec-

Figure 10. Schematic showing function arrangement of balun.

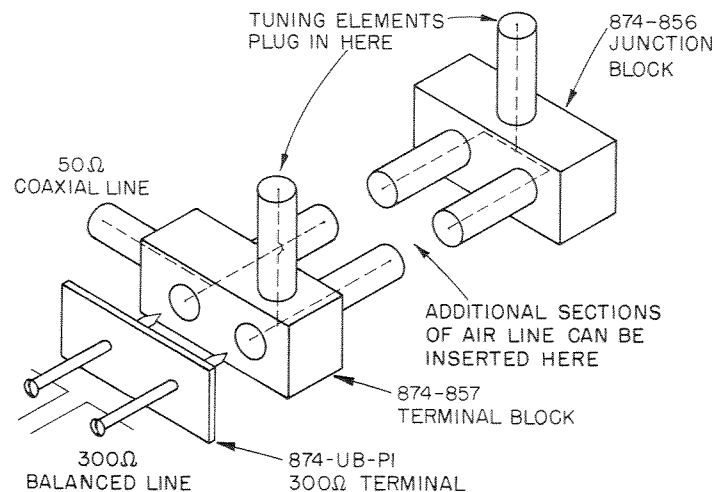

tions of coaxial line and two stub lines. The lengths of the sections of coaxial line are changed for the various frequency bands, and at the low frequencies two Type 874-VC Variable Capacitors are used in place of the stubs.

The balun can be tuned to the operating frequency very easily by means of the stubs or variable capacitors. The procedure is outlined in the instruction book for the balun. A combination of the balun and the Type 874-LK Constant Impedance Adjustable Line simplifies the measuring process as the correction for the length of 50-ohm line between the balun and the admittance meter can be eliminated.

With the Type 1602-B Admittance Meter, the adjustable line should not be set exactly at a quarter or half wavelength when adjusting the balun tuning, but at any other position. With the line set to a quarter- or half-wavelength, one of the balun adjustments must be made to an infinite admittance which is not practical to do. This is different from the older Type 1602-A Admittance Meter since with this instrument, the errors caused an infinite admittance to be measured as a large finite admittance.

The balun is supplied with terminals designed for use with 300-ohm twin lead.

2.7 MEASUREMENTS ON COMPONENTS AND LUMPED CIRCUITS

The measurement of the admittance or impedance of components or lumped circuits at high frequencies is complicated by many factors, the most important of which generally are: (1) the position of the element with respect to ground, leads, and other circuit elements can have a large effect on the impedance of an element, and (2) the reactances of leads used to connect the component to the measuring device and stray capacitance of the terminals to which the leads are connected may also appreciably affect the measurements.

To minimize the effects of the first difficulty mentioned, the component should be measured while mounted in the position in the circuit in which it is to be used or under as similar conditions as possible. One method of measuring a component in position in a circuit is by connecting it to the measuring instrument by means of a length of flexible or rigid coaxial line as shown in Figure 11. The rigid line is preferred as its characteristic impedance is more uniform. The measured impedance must be corrected for the length of line used as outlined in Paragraph 2.312 or a Type 874-LK Constant-Impedance Adjustable Line can be used to set the over-all line length to a quarter or half wavelength and the corrections eliminated as outlined in the same paragraph.

In order to minimize the effects of the lead and terminal reactances, the leads used to connect the component to the instrument or to the end of the coaxial line from the instrument should be made as short as possible.

The leads referred to do not include those normally used to connect the unknown to the circuit in which it is used. If the leads are short, the stray

Figure 11. Method of connecting a component or a lumped circuit to the admittance meter using a short length of 50-ohm cable.

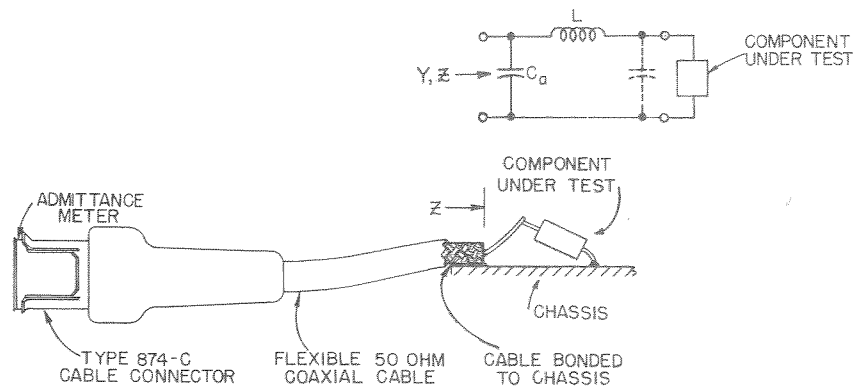

reactances can be considered as lumped into two elements: a shunt capacitance across the end of the measuring line, and an inductance in series with the line as shown in Figure 11. The lead and terminal reactances affect the measured admittance, Y_m , as can be seen from the equivalent circuit in the figure. In order to determine the actual admittance of the unknown, the indicated admittance should be corrected for the length of coaxial line in the circuit and then the effective admittance, Y_e , corrected for the effects of the lead and terminal reactances using the following equations:

$$G_x = \frac{G_e}{D} \quad (27)$$

$$B_x = \frac{B'_e \left(1 - \frac{B'_e}{B_L}\right) - \frac{G_e^2}{B_L}}{D} \quad (28)$$

where

$$D = \left(1 - \frac{B'_e}{B_L}\right)^2 + \left(\frac{G_e}{B_L}\right)^2 \quad (29)$$

$$B'_e = B_e - B_a = B_e - \omega C_a \times 10^3 \text{ millimhos} \quad (30)$$

$$B_L = -\frac{10^3}{\omega L} \text{ millimhos} \quad (31)$$

where L is the magnitude of the lead inductance in henries, and C_a is the magnitude of the shunt capacitance in farads. All admittances are in millimhos.

If the effective impedance, Z_e , rather than the admittance is measured, the following equations should be used to correct for the lead reactances:

$$R_x = \frac{R_e}{D} \quad (32)$$

$$X_x = \frac{X_e - \frac{R_e^2}{X_a} - \frac{X_e^2}{X_a}}{D} - X_L \quad (33)$$

$$D = \left(1 - \frac{X_e}{X_a}\right)^2 + \left(\frac{R_e}{X_a}\right)^2 \quad (34)$$

$$X_a = -\frac{1}{\omega C_a} \quad (35)$$

$$X_L = \omega L \quad (36)$$

The magnitudes of the lead and terminal reactances or susceptances can be determined from measurements of the susceptance seen with the leads short-circuited and open-circuited at the unknown end. For this approximation to hold, the lead inductive susceptance should be greater than five times the lead capacitive susceptance.

A somewhat better approximation can be made by distributing the lead capacitance between the ends of the leads as shown by the dotted capacitor. The ratio of the two capacitances can be estimated from the physical configuration of the circuit.

An even better approximation can be made when the leads are reasonably long if the inductance and capacitance are assumed to be uniformly distributed and the leads are treated as a section of transmission line. The characteristic impedance, Z_0 , or admittance, Y_0 , and the tangent of the electrical length, $\tan 2\pi l_e$, are related to the short- and open-circuit impedances, Z_{sc} and Z_{oc} , or admittances, Y_{sc} and Y_{oc} , by the expressions:

$$Z_0 = \sqrt{Z_{oc} Z_{sc}} \quad (37)$$

$$\tan 2\pi l_e = \pm \sqrt{\frac{-Z_{sc}}{Z_{oc}}} = \frac{X_{sc}}{Z_0} \quad (38)$$

$$Y_0 = \sqrt{Y_{oc} Y_{sc}} \quad (39)$$

$$\tan 2\pi l_e = \pm \sqrt{\frac{-Y_{oc}}{Y_{sc}}} = \frac{B_{oc}}{Y_0} \quad (40)$$

Equations (11) or (12) or the Smith Chart can be used to correct the mea-

sured impedance for the effect of the equivalent section of transmission line. In most cases the capacitance is not uniformly distributed but the approximation usually gives reasonably accurate results.

In many cases more accurate measurements can be made using the Type 874-M Component Mount shown in Figure 12 on which the component or lumped circuit can be mounted. The end of the center conductor of a section of air line is used as the ungrounded terminal and the outer conductor is extended in the form of a disk for a ground plane. The line can be short-circuited at

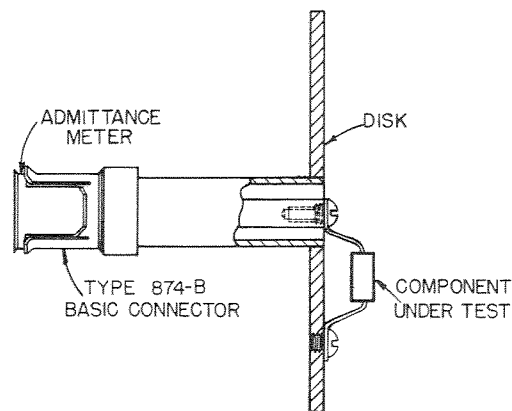

Figure 12. Sketch of Type 874-M Component Mount and method of connecting component for measurement.

the terminal by a very low inductance disk or the mount can be disconnected and replaced by a Type 874-WN3 or WO3 Short- or Open-Circuit Termination Unit in order to measure the line length or adjust the line length as outlined in Paragraph 2.312. The distance from the front face of the bead in the connector on the mount is located 3 cm away from the ground plane surface and hence the termination units referred to place a short- or open-circuit effectively at the ground plane surface when they are substituted for the component mount.

The reactance of leads used to connect the unknown to the component mount must be corrected for as previously outlined.

The coaxial-line section can be removed from the ground plate if desired by loosening the locking nut and installed in any other plate if a 3/4-27 tapped hole is provided.

The combination of the constant-impedance adjustable line, the component mount and the admittance meter provides a convenient method of measuring the admittance or impedance of components or lumped circuits. The steps in the measurement procedure when the adjustable line is used are:

- (1) Set the equipment²⁰ up as shown in Figure 13.

²⁰See Paragraph 2.311.

(2) Connect the Type 874-WN3 Short Circuit in place of the component mount if impedance is to be measured and the Type 874-WO3 Open Circuit if admittance is to be measured.²¹ For maximum accuracy measure impedance if $|Z_x| < Z_0$, and measure admittance if $|Z_x| > Z_0$.

(3) Set the admittance meter to $0 + j0$ with $M = 1$ and vary the length of the adjustable line until a null is obtained. It may be necessary to adjust the conductance arm on the admittance meter slightly to obtain a true null as a result of small losses and errors in the system. Lock the line in this position.

Figure 13. Type 1602 Admittance Meter, Type 874-LK20 Constant-Impedance Adjustable Line, and Type 874-M Component Mount set up for measurements on a resistor.

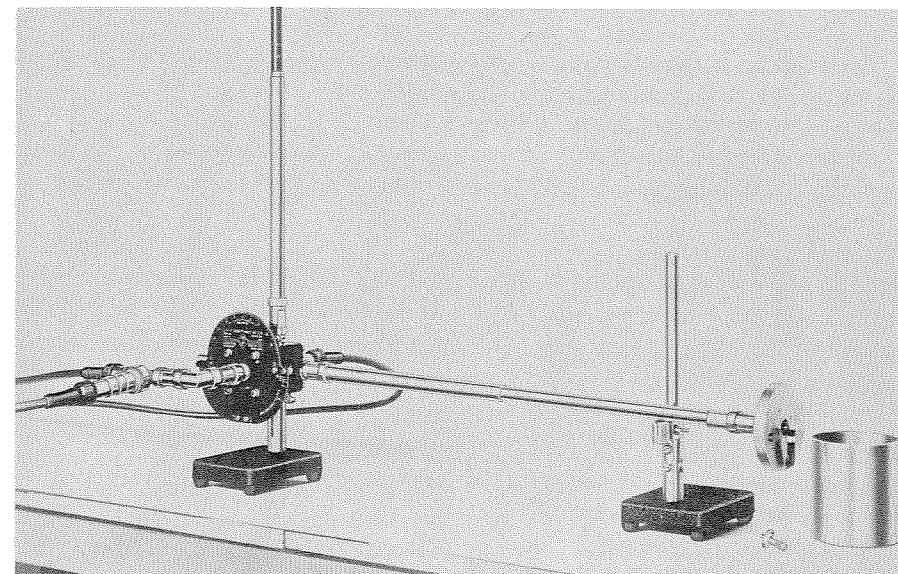

(4) Replace the component mount with the component connected and measure the admittance by balancing the admittance meter.

(5) If the Type 874-WO3 Open Circuit was used (a half-wave line) the dial readings are the components of the effective admittance, Y_e , appearing across the terminals of the component mount. If the Type 874-WN3 Short Circuit was used (a quarter-wave line), multiply the dial readings by 2.5 to obtain the effective resistance and reactance.

(6) Correct the effective admittance or impedance for the lead reactances using Equations (27) and (28) or (32) and (33). The result is the admittance or impedance of the unknown.

²¹See Paragraph 2.3121.

If the impedance is large compared to 50 ohms, the most accurate results are obtained when the admittance is measured using a half-wave line, and if the impedance is small compared to 50 ohms, the most accurate results are obtained when the impedance is measured using a quarter-wave line.

2.71 EXAMPLE OF THE MEASUREMENT OF A RESISTOR USING THE TYPE 874-LK LINE

For example if a resistor is measured at 500 Mc using the component mount and a quarter-wave line, and the conductance and susceptance dial readings are $G = 18.9$, $B = +1.0$, $M = 2$, the impedance of the unknown is:

$$R = 2.5 \times 2 \times 18.9 = 94.5 \text{ ohms} \quad \text{and}$$

$$X = +2.5 \times 2 \times 1.0 = +5.0 \text{ ohms}$$

The resistor is mounted by its own leads which are included as part of the resistor, hence no corrections need be made for them. However, the stray capacitance between the end of the center conductor and the ground plate is not part of the unknown and should be corrected for. The magnitude of the stray capacitance can be determined by a measurement with the resistor disconnected. For the best accuracy, the constant-impedance line should be adjusted to a half-wavelength with the Type 874-W03 Open-Circuit Termination Unit connected in place of the component mount. When the component mount is replaced and the admittance meter balanced, the measured susceptance will be the susceptance of the stray capacitance. The open-circuit termination is preferred to the short-circuit termination as the stray capacitance is small and the measured admittance will be close to that of an open circuit, hence the accuracy will be much greater when the initial adjustments are made using an open circuit.

In the example the measured susceptance is $+1.6$ millimhos which indicates a capacitance of $0.5 \mu\text{mf}$.

Corrections for the effect of the stray capacitance can be made using Equations (32) and (33).

$$X_a = -\frac{1}{\omega C_a} = -625$$

$$X_L = 0$$

$$R_e = 94.5 \text{ ohms}$$

$$X_e = +5.0 \text{ ohms}$$

$$D = \left(1 - \frac{5.0}{-625}\right)^2 + \left(\frac{94.5}{625}\right)^2 = 1.016 + .023 = 1.039$$

$$R_x = \frac{94.5}{1.039} = 91.0 \text{ ohms}$$

$$X_x = \frac{+5.0 - \frac{94.5^2}{-625} - \frac{5.0^2}{-625}}{1.039} = \frac{+19.3}{1.039} = +18.6 \text{ ohms}$$

The measured resistance is lower than the nominal value of the resistor due to the effect of the shunt capacitance of the resistor.

If additional leads had been used to mount the resistor, the capacitance of the added lead would be included in the stray capacitance and measured as indicated above with the resistor disconnected. The lead inductance could be measured by connecting the lead to ground, at the point of connection to the resistor, by means of a low-inductance copper sheet or strap. For this measurement the constant-impedance line should be adjusted to a quarter-wave length with a Type 874-WN3 Short-Circuit Termination Unit connected in place of the component mount. The component mount should then be replaced with the lead short circuited and the lead inductive reactance measured. The inductive reactance should be less than $1/5$ of the capacitive reactance of the lead or the results will be appreciably in error. If the inductive reactance is larger than $1/5$ of the capacitive reactance, the transmission-line approximation outlined in Paragraph 2.7 should be used.

If the component mount is not used and the resistor is connected across the end of a section of transmission line, the same method as outlined above can be used for the measurement except that the short and open circuits must be made differently. Probably the best arrangement is to have two extra lengths of the same cable of identical length to the one used for the measurement. One of these cables should be short circuited by means of a low inductance short circuit as outlined in Paragraph 2.3127, and the other should have its center conductor cut off directly at the end of the braid. The second cable approximates an open circuit with the stray capacitance from the end of the center conductor to ground causing small errors. These cables can be substituted for the original cable when the constant-impedance adjustable line is set.

The measuring cable can also be short-circuited and open-circuited directly at the unknown end as outlined above. In this case the procedure should be planned to make the open circuit last as it is difficult to reconnect a lead to the center conductor once it has been cut off. At the lower frequencies, in most cases, the center conductor can be left extending a small fraction of an inch from the end of the cable for the open-circuit measurement without causing a significant error and the lead soldered to the stub.

2.72 EXAMPLE OF MEASUREMENT OF A RESISTOR WITHOUT THE TYPE 874-LK LINE

If the resistor used in the above example is measured mounted on the component mount which is directly connected to the admittance meter, the effect of the length of 50-ohm line on the admittance must be corrected for.

First the component mount terminals are short circuited or a Type 874-WN3 Short-Circuit Termination Unit is substituted for the component mount and the admittance measured.

The measured admittance, Y_m , is $0 - j 17.2$ millimhos. The point corresponding to this admittance is found on the Smith Chart as shown in Figure 14. A line is then drawn through the point and the center of the chart. This line intersects the WAVELENGTHS TOWARD LOAD scale at 0.1124 wavelengths. Since the termination is a short circuit or an infinite susceptance, the length of the transmission line is the distance between the point found on the scale and the 0.25 wavelengths point which corresponds to an infinite admittance. This distance is 0.1376 wavelengths.

The resistor or the component mount is then connected and the admittance measured. The measured admittance, Y_m , is $17.3 + j 11.8$ millimhos. The point corresponding to this admittance is found on the Smith Chart as shown on Figure 14 and a line drawn through the point and the center of the chart. The intersection of this line and the WAVELENGTHS TOWARDS LOAD scale is at 0.3678 wavelengths. The transmission line length is 0.1376 wavelengths which when added to 0.3678 is 0.5054 wavelengths. The 0.5 can be subtracted and the result is 0.0054 wavelengths. This point is found and a line drawn through it and the center of the chart. A circle with its center at the center of the chart is then drawn through the point on the chart corresponding to the measured admittance. The coordinates of the intersection of this circle and the line just drawn are the coordinates of the effective admittance appearing across the end of the line. The effective admittance is $10.6 - j 0.5$ millimhos.

The effective impedance of the resistor can be determined by multiplying the coordinates of the intersection of the extension of the last straight line drawn beyond the center of the chart and the circle, located 180° around the circle, by 2.5. The effective impedance is $(37.8 + j 2.0) \times 2.5 = 94.5 + j 5$ ohms which is the same as measured using the other method.

The correction for the lead reactances can be made in the same way as in the previous example except the lead capacitance and inductance must be determined by measurements of the type described above.

2.8 OPERATION AT FREQUENCIES BELOW 40 MC

The lowest calibrated frequency on the Type 1602-P3 Variable Air Capacitor is 41 Mc. For operation at lower frequencies, set the capacitor to 42 Mc and multiply the indicated susceptance by the factor corresponding to the operating frequency found on the chart in Figure 15. The conductance measurement is unaffected by frequency.

In general the over-all sensitivity of the instrument will decrease as the frequency is lowered as the mutual coupling is proportional to frequency.

Reflection coefficient, impedance matching, impedance comparison, and impedance magnitude measurements can be made without corrections at frequencies as low as adequate sensitivity is obtained.

ADMITTANCE COORDINATES—20-MILLIMHO CHARACTERISTIC ADMITTANCE

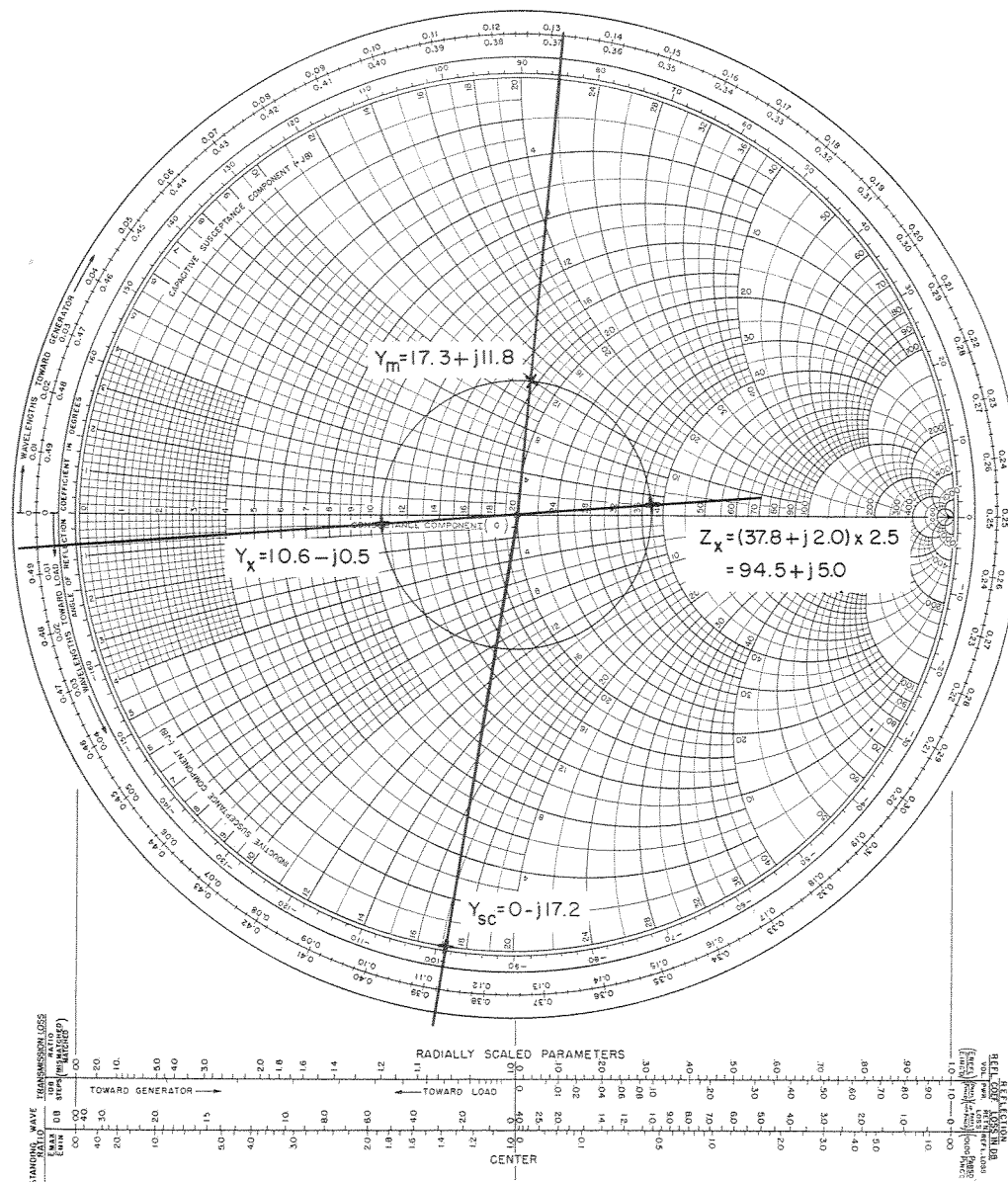

Figure 14. The use of the Smith Chart to calculate the admittance and impedance of a resistor from values measured on the Admittance Meter.

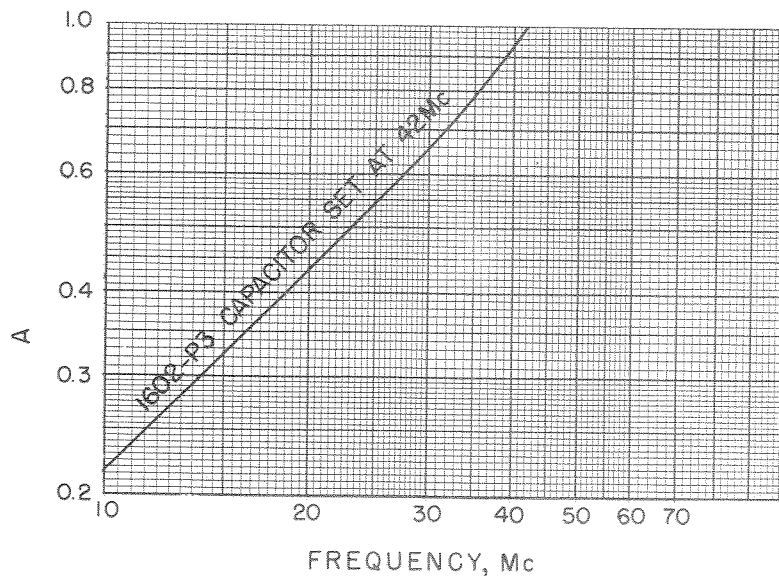

Figure 15. Correction chart for susceptance reading at frequencies below the calibrated range of the susceptance standard.

2.9 OPERATION AT FREQUENCIES ABOVE 1000 MC

Admittance measurements can also be made at frequencies up to about 1500 Mc with somewhat less accuracy than is obtained at lower frequencies. The Type 1602-P1 Calibrated Stub can be used and set at a white scale reading approximately 1/5 the actual frequency. A more exact setting can be made using the method outlined in Paragraph 3.1 with a Type 874-WN Short-Circuit Termination Unit connected to the unknown connector to prevent resonances in this branch from causing errors. The sign of the measured susceptance is indicated by the white + and - signs on the dial.

Impedance matching and comparison measurements can be made at frequencies up to about 1500 Mc with accuracies approximating those obtained at lower frequencies.

2.10 ERRORS

The two most important sources of error in the admittance meter are the mutual couplings between different branches of the tee and the inductance of the sections of line between junction and the center of the coupling loops. These errors can be corrected for.

The magnetic shielding of the junction is not perfect and small mutual couplings exist between each branch line and the loops associated with the other branches. The magnitudes of all of these couplings are practically the same and equal to about 0.85 percent of the normal couplings. The errors produced by cross couplings are independent of frequency and are zero in magnitude when a matched line is measured ($Y_x = 20$ millimhos). In general the errors are small when the measured admittance is small and increase as the magnitude of the measured admittance becomes large compared to 20 millimhos.

2.101 CORRECTION FOR CROSS-COUPLING ERRORS.

The error produced by cross-couplings is a function of the measured admittance and of the sign of the standard susceptance. Corrections for the couplings can be made using the following equations:

$$G_e = \frac{G_m - S \times 0.0085 B_m + 0.17}{D} \quad (41)$$

$$B_e = \frac{B_m + S(0.0085 G_m + 0.17)}{D} \quad (42)$$

$$D = 1 + 0.00042 G_m + S \times 0.00042 B_m$$

S = +1 when the orange scale on susceptance stub is used.

S = -1 when the white scale on susceptance stub is used.

where G_m and B_m are the measured conductance and susceptance and G_e and B_e are the effective conductance and susceptance.

When G_m is small compared to B_m or to 20 millimhos, the correction charts shown in Figures 16a and 16b can be used to obtain the susceptance correction. The conductance correction under most conditions is relatively small and cannot be determined from the chart, however, for many measurements the accuracy of the conductance measurement is of minor importance.

2.1011 Example of Cross-Coupling Correction Using Chart: If the measured conductance is 3.5 millimhos and the measured susceptance is +100 millimhos; the susceptance correction can be obtained from the chart in Figure 16a. The white stub scale is used for this measurement; therefore, $\Delta b = +4.2$ and $B_e = B_m + \Delta b = 104.2$ millimhos.

2.1012 Example of Cross-Coupling Correction Using Equations: The corrections in the example shown above can be determined using Equations (41) and (42) in the following manner.

$$G_e = \frac{3.5 + 0.0085 \times 100 + 0.17}{1 + 0.00042 \times 3.5 - 0.00042 \times 100} = 4.9 \text{ millimhos}$$

$$B_e = \frac{100 - 0.0085 \times 3.5 - 0.17}{1 + 0.00042 \times 3.5 - 0.00042 \times 100} = 104.2 \text{ millimhos}$$

2.102 JUNCTION INDUCTANCE ERRORS:

In the Type 1602-B Admittance Meter the effect of the junction inductance has been compensated for by adding a small shunt capacitance in each branch on the output side of each coupling loop. This capacitance is of the proper magnitude to make the capacitance and inductance form a short section of transmission line having a 50-ohm characteristic impedance. This additional section of line merely increases the effective length of line between the connector and center of the coupling loop slightly. Variations in this line length have no effect on the VSWR and do not require additional corrections as the additional section of line is added to line already present and any line-length corrections made will normally include the effect of the overall line length.

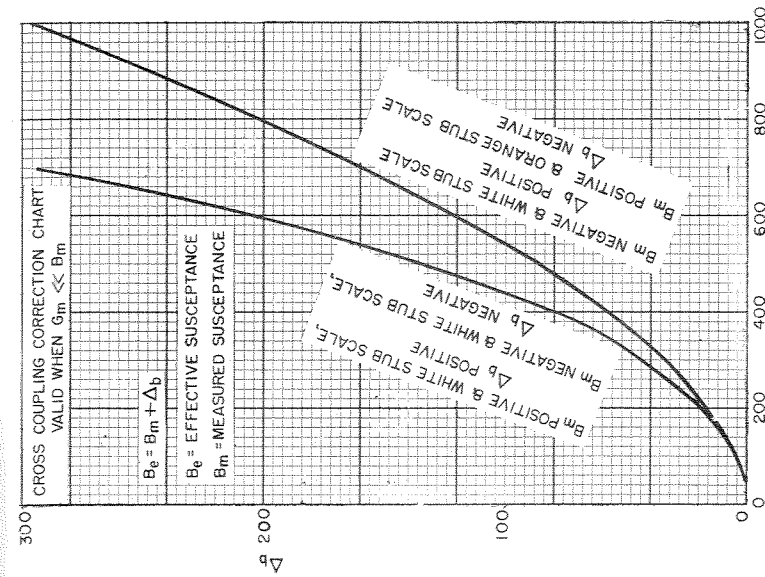

(Left) Figure 16a. Correction chart for the error in susceptance due to cross couplings. (Susceptance less than 120 millimhos.) (Above) Figure 16b. Correction chart for the error in susceptance due to cross couplings. (Susceptance large.)

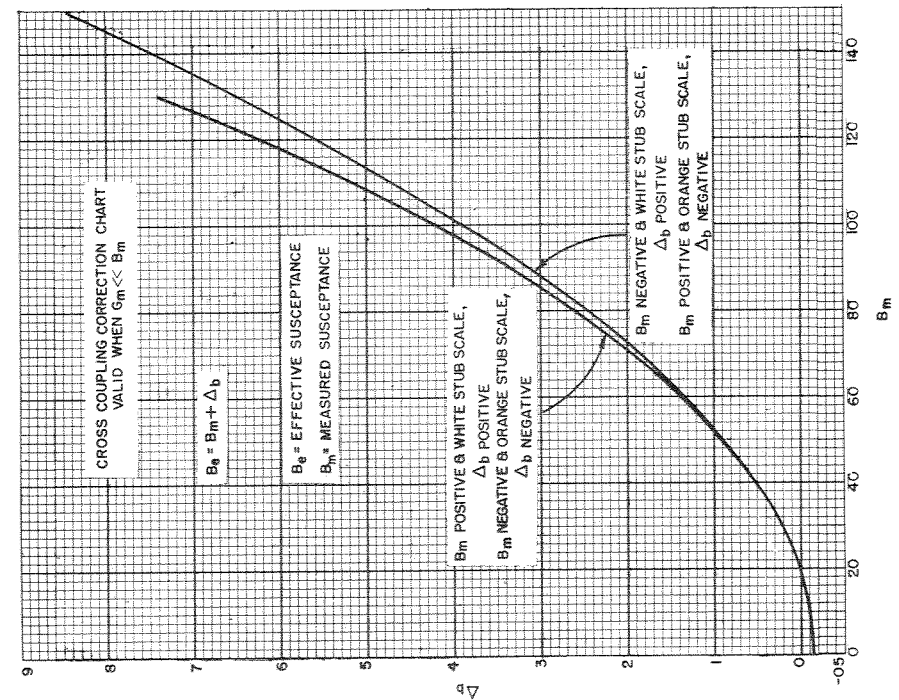

3.0 CHECKS AND ADJUSTMENTS

3.1 CHECKING CALIBRATION OF STANDARD SUSCEPTANCE STUB

The setting of the susceptance stub can be corrected for errors in the frequency calibration of the signal source or, if the frequency is known, errors in the calibration of the stub in the following manner.

With the Type 1602-P4 50-ohm Termination inserted in the G_s connector, the calibrated stub inserted in the B_s connector, and the Y_x connector shielded by the shell of a Type 874 Connector, set the conductance indicator to 20, the susceptance indicator to zero, and the multiplying factor to infinity (∞). Accurately note the indication on the detector. Then set the conductance indicator to zero, the susceptance indicator to + or -20, and again note the output. If the output indications are the same for both measurements, the stub is correctly set. If they are different adjust the stub to make the second reading equal the first. Since changes in the stub length affect the load on the generator, it is necessary to recheck the first measurement to make sure that the applied voltage has not changed, and if it has, repeat the measurement. At frequencies below 1000 Mc do not have anything connected to the unknown connector on the admittance meter except a Type 874-WO Open-Circuit Termination Unit or resonances in the connected line may cause errors. At frequencies above 1000 Mc a Type 874-WN Short-Circuit Termination should be plugged into the unknown connector to avoid errors caused by resonances in the short section of line.

3.2 SERVICING THE SUSCEPTANCE STANDARD STUB

If the susceptance standard stub becomes erratic, it can usually be repaired by cleaning and if necessary by increasing the spring pressure on the contact fingers. The stub can be taken apart by unscrewing the 3/4 inch coupling nut with GENERAL RADIO CO. TYPE 874 stamped on it which is located at the base of the connector. The contacts and tube should be cleaned with a solvent and relubricated with a light grease or Tycol oil (Allweave Tycol, Tidewater Association Oil Co.). The tips of the outer contact fingers should have a diameter of at least .575 inches (approximately .010 inches greater than the inside diameter of the tube). If all of the fingers are not sprung out to the diameter mentioned, they should be re-formed to do so. The inside diameter of the tips of the inner contacts should be sprung in to a diameter of .238. If they are not, they should be reformed to this dimension.

TABLE 1

$A_2 - A_1$ db	Γ V_1/V_2	VSWR	$A_2 - A_1$ db	Γ V_1/V_2	VSWR
1	.8913	17.41	17	.1413	1.33
1.2	.8710	14.50	18	.1259	1.29
1.4	.8511	12.43	19	.1122	1.24
1.6	.8318	10.90	20	.1000	1.22
1.8	.8128	9.66	21	.0891	1.194
2	.7943	8.73	22	.0794	1.170
2.2	.7762	7.94	23	.0708	1.153
2.4	.7586	7.29	24	.0631	1.136
2.6	.7413	6.73	25	.0562	1.120
2.8	.7244	6.26	26	.0501	1.105
3	.7079	5.85	27	.0447	1.093
3.5	.6683	5.03	28	.0398	1.083
4	.6310	4.42	29	.0355	1.074
4.5	.5957	3.95	30	.0316	1.066
5	.5623	3.57	31	.0282	1.058
5.5	.5309	3.26	32	.0251	1.051
6	.5012	3.01	33	.0224	1.046
6.5	.4732	2.80	34	.0200	1.041
7	.4467	2.62	35	.0178	1.036
7.5	.4217	2.46	36	.0158	1.032
8	.3981	2.32	37	.0141	1.029
8.5	.3758	2.20	38	.0126	1.027
9	.3548	2.10	39	.0112	1.023
9.5	.3350	2.01	40	.0100	1.020
10	.3162	1.92	42	.0079	1.016
11	.2818	1.79	44	.0063	1.013
12	.2512	1.67	46	.0051	1.010
13	.2239	1.58	48	.0040	1.008
14	.1995	1.50	50	.0032	1.006
15	.1778	1.43	55	.0018	1.004
16	.1585	1.37	60	.0010	1.002

4.0 ACCESSORY MULTIPLIER PLATES

The Types 1607-P10 and 1607-P11 Multiplier Plates supplied are used to improve accuracy, resolution, and range of the Type 1602-B Admittance Meter. For an admittance measurement of 2 mmhos or less, the accuracy is improved from the specified ± 0.2 mmho to ± 0.04 mmho and the resolution is increased by a factor of 10. With the appropriate installation of the multiplier plate, accuracy is also improved for admittance measurements of values greater than 200 mmhos since the setting errors are minimized. In this application, exact MULTIPLYING FACTOR settings can now be made above 10, since the existing dial calibrations are multiplied by 10 to correspond to 10, 11, 12, 15, 20, 30, 50, 100, and 200.

To realize the full advantage of the multiplier plates, use an open circuit to establish the transmission-line reference plane for low-admittance measurements and use a short circuit to establish this reference plane for high-admittance measurements. The reference plane can be determined in terms of the electrical length of line within the instrument as described in paragraph 2.3125.

The Type 1607-P10 Single Multiplier Plate (see Figure 17) has four coupling holes, three large (A) and one small (B). The plate can be oriented so that the small hole is under any one of the three coupling loops, thereby reducing the coupling to that loop. Table 2 summarizes the effect obtained in each case.

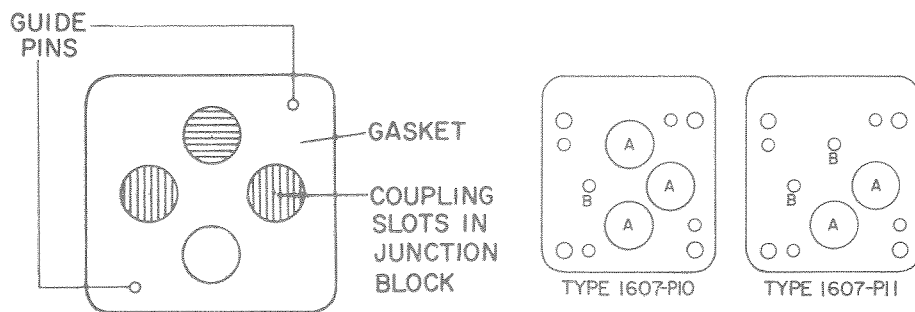

Figure 17. Left to right: Type 1602-94 Gasket, Type 1607-P10 Single Multiplier Plate, Type 1607-P11 Double Multiplier Plate

TABLE 2.

PLATE USED	UNKNOWN QUANTITIES TO BE MEASURED	POSITION OF SMALL COUPLING HOLE(S)	EFFECT	
			SCALE	MULTIPLY BY
Type 1607-P10	Conductance, < 2 mmhos	G	CONDUCTANCE	0.1
	Susceptance, < 2 mmhos	B	SUSCEPTANCE	0.1
	Conductance and susceptance, > 200 mmhos	M	MULTIPLYING FACTOR	10
Type 1607-P11	Conductance and susceptance, < 2 mmhos	G and B	CONDUCTANCE and SUSCEPTANCE	0.1
	Conductance, > 200 mmhos Susceptance, * < 20 mmhos	B and M	CONDUCTANCE	10

Form 741-G (-P10, -P11)

The Type 1607-P11 Double Multiplier Plate has four coupling holes, two large (A) and two small (B). This plate should be oriented so that the two small holes are under the CONDUCTANCE and SUSCEPTANCE loops. The effect on scale readings is shown in Table 2.

Before a multiplier plate is installed, the Type 1602-P1 or 1602-P3 Susceptance Standard should be set as described in paragraph 3.1. These settings must be made while the Type 1602-94 Gasket is still in place, unless the Type 1607-P10 Plate is to be installed with the small hole over the MULTIPLIER loop.

To install either of the multiplier plates, proceed as follows:

- a. Loosen the four captive screws at the rear of the junction block and remove the indicator head.
- b. Remove the gasket and insert the multiplier plate in its place. Refer to Table 2 for proper orientation.
- c. Replace the indicator head and tighten the four captive screws.

NOTE: Either the gasket or one of the multiplier plates should always be in place between the indicator head and the junction block. The gasket or plate should be installed with the lips on the holes protruding toward the slots on the junction block.

The Type 1607-P11 Multiplier Plate can also be used in the positions listed in Table 2, although the measurement accuracy is reduced for the quantity marked with an asterisk.

TYPE 874 COAXIAL COMPONENTS

TYPE 874 CABLE CONNECTORS							
CONNECTOR TYPE	CABLE	CABLE LOCKING	PANEL FLANGED	PANEL LOCKING	PANEL LOCKING RECESSED		
APPLICABLE CABLE TYPES	50-OHM	874-A2	-CA	-CLA	-PBA	-PLA	-PRLA
		RG-8A/U					
		RG-9B/U					
		RG-10A/U					
		RG-87A/U					
		RG-116/U					
		RG-156/U					
		RG-165/U					
		RG-166/U					
		RG-213/U					
	RG-214/U						
	RG-215/U						
	RG-225/U						
	RG-227/U						
	RG-11A/U						
	RG-12A/U						
	RG-13A/U						
	RG-63B/U						
	RG-79B/U						
	RG-89/U						
RG-144/U							
RG-146/U							
RG-149/U							
RG-216/U							
50-OHM	874-A3						
	RG-29/U						
	RG-55/U						
	(Series)						
	RG-58/U	-C58A	-CL58A	-P58A	-PL58A	-PRL58A	
	(Series)						
	RG-141A/U						
	RG-142A/U						
	RG-159/U						
	RG-223/U						
NON-50-OHM	RG-59/U						
	RG-62/U						
	(Series)						
	RG-71B/U	-C62A	-CL62A	-P62A	-PL62A	-PRL62A	
	RG-149/U						
RG-210/U							
NON-50-OHM	RG-174/U						
	RG-183/U						
	RG-316/U	-C174A	-CL174A	-P174A	-PL174A	-PRL174A	
	RG-161/U						
	RG-187/U						
RG-179/U							

Example: For a locking cable connector for RG-8A/U, order Type 874-CL8A.

TYPE 874 ADAPTORS		
TO TYPE		874-
BNC	plug	QBJA QBJL*
	jack	QBPA
C	plug	QCJA QCJL*
	jack	QCP
HN	plug	QHJA
	jack	QHFA
LC	plug	QLJA
	jack	QLPA
LT	plug	QLTJ
	jack	QLTP
Microdot	plug	QMDJ QMDJL*
	jack	QMDP
N	plug	QNJA
	jack	QNJL* QNP
SC (Sandia)	plug	QSCJ
	jack	QSCJL* QSCP
TNC	plug	QTNJ QTNJL*
	jack	QTNP
UHF	plug	QUJ
	jack	QUJL* QUP
UHF 50-Ω Air Line	7/8-in.	QU1A
	1-5/8-in.	QU2
	3-1/8-in.	QU3A

*Locking Type 874 Connector.

Example: To connect Type 874 to a Type N jack, order Type 874-QNP.

CONNECTOR ASSEMBLY TOOLS	
TYPE 874-	FUNCTION
TOK	Tool Kit
TO58	Crimping Tool
TO8	Crimping Tool

OTHER COAXIAL ELEMENTS			
TYPE 874-		TYPE 874-	
A2	50 Ω cable (low loss)	LR	radiating line
A3	50 Ω cable	LTL	trombone constant-Z line
D20L, D50L	20-, 50-cm adjustable stubs	ML	component mount
EL, EL-L	90° ell	MB	coupling probe
F185L	185-Mc low-pass filter	MR, MRL	mixer-rectifier
F500L	500-Mc low-pass filter	R20A, R20LA	patch cord, double coax
F1000L	1000-Mc low-pass filter	R22A, R22LA	patch cord, double coax
F2000L	2000-Mc low-pass filter	R33	patch cord, single coax
F4000L	4000-Mc low-pass filter	R34	patch cord, single coax
G3, G3L		T, TL	tee
G6, G6L	{ 3-, 6-, 10-, & 20-db attenuators	UBL	balun
G10, G10L		VCL	variable capacitor
G20, G20L		VI	voltmeter indicator
GAL	adjustable attenuator	VQ, VQL	voltmeter detector
H500L	isolator	VR, VRL	voltmeter rectifier
H1000L	isolator	W100	100-Ω termination
H2000L	isolator	W200	200-Ω termination
JR	rotary joint	W50, W50L	50-Ω termination
K, KL	coupling capacitor	WN, WN3	short-circuit terminations
L10, L10L	{ 10-, 20-, & 30-cm rigid air lines	WO, WO3	open-circuit terminations
L20, L20L		X	insertion unit
L30, L30L		XL	series inductor
LAL	33-58 cm adjustable line	Y	cliplock
LK10L, LK20L	constant-Z adjustable lines	Z	stand

MISCELLANEOUS COAXIAL CONNECTORS		
CONNECTOR TYPE	TYPE NO.	USED WITH
Basic	874-B	50-ohm Air Line
Basic Locking	874-BL	50-ohm Air Line
Panel Locking	874-PLT	Wire Lead
Panel Locking Recessed	874-PRLT	Wire Lead
Panel Locking Feedthrough	874-PFL	Type 874 Patch Cords

L suffix indicates locking Type 874 Connector.

FOR COMPLETE DETAILS, REFER TO THE GENERAL RADIO CATALOG.