

OPERATING INSTRUCTIONS



**TYPE 1150-A**  
**DIGITAL FREQUENCY METER**

1150-A

G E N E R A L R A D I O C O M P A N Y

# OPERATING INSTRUCTIONS

## TYPE 1150-A

# DIGITAL FREQUENCY METER

Form 1150-0100-B  
October, 1963

Copyright 1962 by General Radio Company  
West Concord, Massachusetts, USA

GENERAL RADIO COMPANY  
WEST CONCORD, MASSACHUSETTS, USA

# TABLE OF CONTENTS

Section 1. INTRODUCTION . . . . .	1
Section 2. OPERATING PROCEDURE . . . . .	1
2.1 Controls and Connectors . . . . .	1
2.2 Installation . . . . .	4
2.3 Frequency Measurement . . . . .	6
2.4 Manual Totalizing Operation . . . . .	6
2.5 Use of an External Reference Source . . . . .	6
2.6 Connection to Accessory Equipment . . . . .	6
Section 3. PRINCIPLES OF OPERATION . . . . .	8
3.1 General . . . . .	8
3.2 Ring Counting Units . . . . .	9
3.3 Input Amplifier . . . . .	10
3.4 Program Circuits . . . . .	10
3.5 Time Base . . . . .	11
3.6 Power Supplies . . . . .	12
Section 4. SERVICE AND MAINTENANCE . . . . .	12
4.1 General . . . . .	12
4.2 Routine Maintenance . . . . .	13
4.3 Internal Adjustments . . . . .	13
4.4 Trouble-Shooting Procedure . . . . .	14



Figure 1-1. Panel view of the Type 1150-A Digital Frequency Meter.

## SPECIFICATIONS

**Frequency Range:** 10 cps to 300 kc.

**Input Impedance:** AC-coupled; approximately 0.5 megohm shunted by less than 100 pf.

**Sensitivity:** Better than 1 volt, peak-to-peak; for pulse input, duty ratio should be between 0.2 and 0.8. For input pulses of higher than minimum amplitude, duty ratio becomes less important.

**Display:** 5-digit, in-line Numerik register, incandescent-lamp operated.

**Display Time:** Adjustable from 0.5 to 5 seconds, or infinity.

**Counting Interval:** 0.1, 1, or 10 seconds, or can be set manually.

**Accuracy:**  $\pm 1$  count  $\pm$  crystal-oscillator stability.

### Crystal-Oscillator Stability

**Short-Term:** Better than  $\frac{1}{2}$  part per million.

**Cycling:** Less than counter resolution.

**Temperature Effects:** Less than  $2\frac{1}{2}$  parts per million for rise of 0 to 50 C ambient.

**Warmup:** Within 1 part per million after 15 minutes.

**Aging:** Less than 1 part per million per week after four weeks, decreasing thereafter.

**Crystal-Frequency Adjustment:** The frequency is within 10 parts per million of 100 kc when shipped. Frequency adjustment provided.

**Power Requirements:** 105 to 125 (or 210 to 250) volts, 50 to 60 cps, 45 watts.

**Accessories Supplied:** TYPE CAP-22 Power Cord, eight replacement incandescent lamps, spare fuses.

**Accessories Available:** TYPE 1136-A Digital-to-Analog Converter (page 99) and TYPE 1137-A Data Printer (page 100) operate from output of TYPE 1150-AP model.

**Cabinet:** Rack-bench (see page 210).

**Dimensions:** Bench model — width 19, height  $3\frac{7}{8}$ , depth  $12\frac{1}{2}$  inches (485 by 99 by 320 mm), over-all; rack model — panel 19 by  $3\frac{1}{2}$  inches (485 by 90 mm); depth behind panel  $12\frac{3}{4}$  inches (325 mm).

**Net Weight:**  $17\frac{1}{2}$  pounds (8 kg).

**Shipping Weight:** 20 pounds (9.5 kg).

General Radio *Experimenter* reference, Vol 36, No. 4, April 1962

Patent Applied For.

## SECTION 1

## INTRODUCTION

The Type 1150-A Digital Frequency Meter (see Figure 1-1) is a general-purpose, basic, digital counter for measuring, setting, and monitoring frequencies, for counting random events, and for industrial counting applications. Among its many frequency measurement applications are the test, adjustment, and calibration of oscillators, telemetering equipment, i-f amplifiers and filters (crystal, mechanical, and magnetostrictive). This frequency meter measures frequencies between 10 cps and 220 kc with a precision of  $\pm 0.1$  cps.

With appropriate transducers, it can be used to measure such physical quantities as pressure, temperature, strain, and weight. In conjunction with an optical or magnetic pickup, it will measure rotational speed.

Other important applications in industry include the counting of units on a production line and other nonperiodic events.

It can be started, stopped, and cleared by external signals, so that it can be used as part of a larger system.

## SECTION 2

## OPERATING PROCEDURE

## 2.1 CONTROLS AND CONNECTORS.

The following table lists the controls and connectors on the Type 1150-A Digital Frequency Meter:



The INPUT binding-post terminals are for connection of the signal to be measured. The lower (ground) terminal is connected directly to the metal case of the instrument.



## TYPE 1150-A DIGITAL FREQUENCY METER

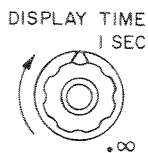

Clockwise rotation of the DISPLAY TIME control increases the time interval for display of the measurement result. The approximate range of display time is one-half to five seconds; the one-second setting is indicated. Rotating the knob fully clockwise activates a switch that gives continuous display (∞ position) until the RESET button is pressed.



The latching-type, pushbutton CHECK switch is activated when the switch is pressed toward the panel and then released. The two positions, one closer to the panel than the other, are indicated by the length of shaft exposed. The position closer to the panel is the normal position for measurement of an input signal. The position farther out from the panel is for self-check operation of the instrument with the internal 100-kc signal connected across the INPUT terminals.



The COUNTING lamp lights while the instrument is measuring and is off during the display and reset intervals. The lamp functions for both automatic and manual operation.

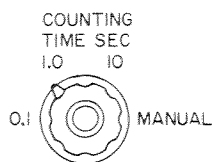

The four positions of the COUNTING TIME SEC control select the time interval for which the input signal is sampled (counted). In the 0.1 position, the sampling interval is 0.1 second and the indicator reads in 10-cycle units; in the 1.0 position, the input is sampled for one second and the indicator reads in cycle-per-second units; the 10 position gives a 10-second sampling interval and a display in 0.1-cycle units; in the MANUAL position, the sampling interval is controlled by the START-STOP switch.



The latching-type, pushbutton START-STOP switch is activated when the switch is pressed toward the panel and then released. The two positions, one closer to the panel than the other, are indicated by the length of shaft exposed. When the COUNTING TIME SEC control is in the MANUAL position, this START-STOP switch controls the time that the input signal is sampled. The sampling interval starts when the switch is set in the position farther out from the panel and stops when the switch is put in the position closer to the panel.



The POWER switch interrupts the 115 volts supplied to the fan motor and the instrument dc supply. As long as the instrument is plugged in, the primary and secondary windings of the power transformer are energized to keep the crystal oven at its proper temperature. Note that line voltage and other voltages are present with power "off".



When the nonlatching, pushbutton RESET switch is pressed momentarily, the display interval or the counting interval is interrupted and a new count is initiated.

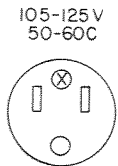

Power-input socket accepts the power cord provided. Instruments are normally supplied for operation from 105 to 125 volts. The power transformer can be reconnected for operation from 210 to 250 volts (refer to Section 2.2.4).



The internally generated, 100-kc reference signal is available at the jack labeled INT 100 KC.

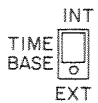

With the TIME BASE slide switch in the INT position, the reference signal is taken from an internal stable crystal oscillator. With the TIME BASE slide switch in the EXT position, an external 100-kc signal should be applied to the lower phone jack. When no external reference is connected, the slide switch should be in the INT position. Operation without an external reference signal and with the switch at EXT will yield incorrect measurements.



The lower phone jack, EXT 100 KC INPUT, is for connection of an external 100-kc reference signal.

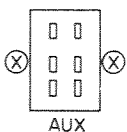

The six-pin AUX plug is to connect the instrument to auxiliary equipment (refer to Section 2.6.3).



The three-connector PHOTOELECTRIC PICKOFF telephone jack is for direct connection of an optical transducer (refer to Section 2.6.2).

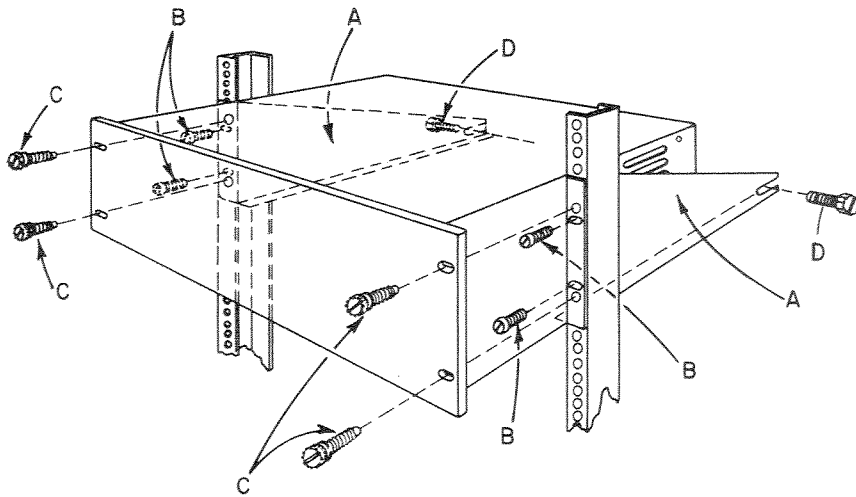

Figure 2-1. Installation of relay-rack model, Type 1150-AR.

## 2.2 INSTALLATION.

2.2.1 INSTRUMENT LOCATION. To cool the internal components, air is vented through an air filter at the rear to an exhaust fan on the left-hand side of the instrument. The frequency meter must be mounted so that air flow is not blocked at either the filter or the exhaust port. The instrument will operate properly in any orientation.

2.2.2 MOUNTING. The instrument is available equipped for either bench or relay-rack mounting. For bench mounting (Type 1150-AM), aluminum end frames are supplied to fit the ends of the cabinet. Each end frame is attached to the instrument with two panel screws and four 10-32 round-head screws with notched washers.

For rack mounting (Type 1150-AR), special rack-mounting brackets are supplied to attach the cabinet and instrument to the relay rack (see Figure 2-1). These brackets permit either cabinet or instrument to be withdrawn independently of the other.

To install the instrument in a relay rack:

- a. Attach each mounting bracket (A) to the rack with two 12-24 round-head screws (B). Use the inside holes on the brackets.
- b. Slide the instrument onto the brackets as far as it will go.
- c. Insert the four panel screws with attached washers (C) through the panel and the bracket and thread them into the rack. The washers are provided to protect the face of the instrument.
- d. Toward the rear of each bracket, put a thumb screw (D) through the slot in the bracket and into the hole in the side of the cabinet.

e. On the rear of the cabinet, remove the two round-head screws that hold the cabinet to the instrument.

To remove the instrument from the rack, remove only the four panel screws with washers (C) and draw the instrument forward out of the rack. To remove the cabinet and leave the instrument mounted in the rack, remove only the two thumb screws (D) at the rear of the brackets and pull the cabinet back off the instrument from the rear of the rack.

2.2.3 ACCESSORIES SUPPLIED. Supplied with the Type 1150-A Digital Frequency Meter are: a Type CAP-22 Three-Wire Power Cord, a Type CDSP-16 phone plug for the INT 100 KC or EXT 100 KC INPUT socket, a Type CDMP-1275-6 six-terminal Jones-type plug for the AUX (auxiliary accessory) connector, eight spare indicator lamps, and spare fuses. The spare indicator lamps are in the front panel, accessible when the indicator bank is removed.

2.2.4 CONNECTION TO POWER SUPPLY. Connect the Type 1150-A to a source of power as indicated on the chassis over the input socket at the rear of the instrument, using the power cord provided. The long cylindrical pin (ground) is connected directly to the metal case of the instrument, and hence to the ground terminal of the INPUT connector on the panel.

While instruments are normally supplied for 115-volt operation, the power transformer can be re-connected for 230-volt service (refer to the schematic diagram, Figure 4-10). When changing connections, be sure to indicate on the chassis the correct input voltage and replace the 0.6-ampere line fuses with fuses rated at 0.3 ampere.

2.2.5 WARM-UP. A 10-minute warm-up period is required after the instrument is plugged in until it reaches stable operation. Errors of several parts

per million in frequency measurement may occur during warm-up. The crystal oven for the internal reference oscillator will then remain at the proper operating temperature as long as the instrument is plugged in, regardless of the setting of the POWER switch.

**2.2.6 CHECK FOR PROPER OPERATION.** Set the rear TIME BASE control to INT, the POWER switch to POWER, and allow a few seconds for the instrument to attain stable operation. Set the COUNTING TIME control to 0.1 SEC, the DISPLAY TIME control to approximately 1 SEC, and set the CHECK and the START-STOP pushbuttons so they are in the position farther out from the panel. The instrument should display 10000 (100 kc) for one second, clear to zero, count again, etc.

With the COUNTING TIME control set to 1.0 or 10, the meter should still measure the frequency within one count. The display will be 00000 because of the change in sampling time.

**2.2.7 APPLYING AN INPUT SIGNAL.** Apply the signal to be measured at the INPUT binding posts on the panel. The lower terminal (ground) is connected to the metal case of the instrument and to the ground connection of the three-wire power cord.

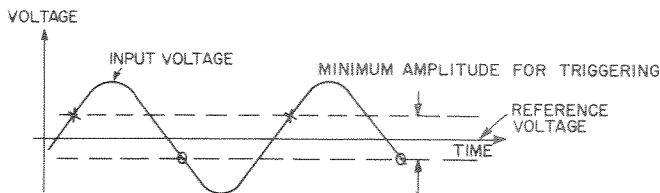

Figure 2-2. Input signal waveform showing points where counts are generated (x) and points where the input circuits reset (O).

The input circuits have a small voltage hysteresis, or backlash. They generate a count (points X in Figure 2-2) every time the signal voltage exceeds the reference voltage by a small amount (approximately 0.2 volt). Before another count can be generated, the circuits must be reset (points O in Figure 2-2) by a decrease in input voltage to a value approximately 0.2 volt below the reference voltage. Because of this hysteretic action, an input voltage of at least 0.4 volt is necessary to generate counts. Since the reference voltage changes with temperature and some noise is always present, an input voltage of at least 1 volt peak-to-peak is specified for proper operation. The input signal is capacitively coupled to the input circuit, so that the reference voltage is approximately the average value of the input signal. The counts are generated when the input signal voltage is increasing (positive slope in Figure 2-2).

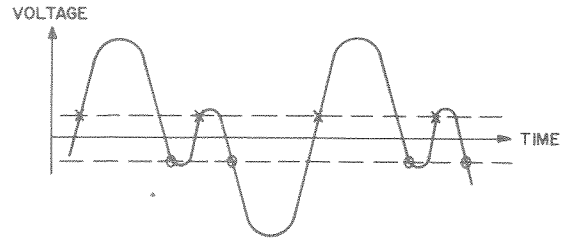

Figure 2-3. Example of an input signal waveform which could generate two counts per cycle.

It is possible to have a waveform that will generate two counts per cycle, such as that shown in Figure 2-3. The input circuits cannot discriminate between the waveforms shown in Figures 2-2 and 2-3 so the frequency indicated for the signal shown in Figure 2-3 may be twice the actual value. To eliminate this type of error, reduce the amplitude of the input signal.

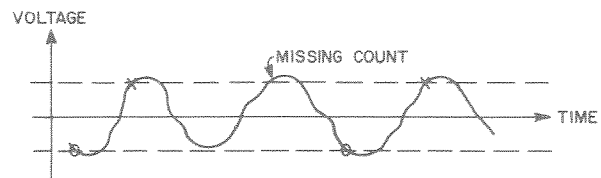

Figure 2-4. Example of an input signal waveform with noise which could cause a missing count.

If the input signal is very close in amplitude to the minimum amplitude for triggering, a slight amount of noise can cause a missing count and corresponding measurement error (see Figure 2-4).

Since the capacitive coupling of the input signal causes the input circuits to generate a count at the average value of the input voltage, a pulse-type input signal should have a duty ratio (ratio of pulse duration to period) between 0.2 and 0.8, depending on the amplitude of the pulse. For the pulse waveform shown in Figure 2-5a, although the peak-to-peak amplitude may be several volts, the average voltage is not sufficient to reset the input circuits. This type of error cannot usually be eliminated by increasing

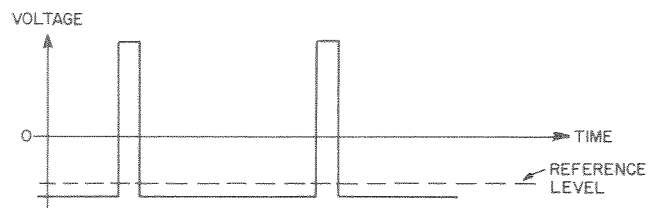

Figure 2-5a. Pulse-type input signal with too low a duty ratio to generate a count.

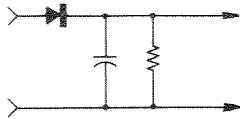

Figure 2-5b. Pulse-shaping circuit to change the waveform shown in Figure 2-5a.

the amplitude of the input signal without overloading the input circuits. It is possible, however, to measure the frequency of very low duty ratio signals by using an external circuit similar to the one shown in Figure 2-5b, which reshapes the waveform.

## 2.3 FREQUENCY MEASUREMENT.

### 2.3.1 GENERAL.

Set the COUNTING TIME control to the desired sampling interval; the longer the counting interval used, the greater the accuracy of measurement. (At 0.1 SEC, the meter will read in tens of cycles; at 1.0 SEC, the meter will read in cycles per second; at 10 SEC, the meter will read in tenths of cycles per second.) The indicated frequency is the value averaged over the last counting interval.

Set the DISPLAY TIME control to a convenient display interval. (Range is approximately 0.5 to 5 seconds.) For easiest reading, set this control for minimum time between the end of the display interval and start of the next counting interval. This is particularly helpful when one-second counting interval is used.

To retain the displayed count, rotate the DISPLAY TIME control clockwise until the switch is activated ( $\infty$  position). The display will be held until the RESET button is pushed to reset the counting units to zero and initiate a new count.

**2.3.2 MANUAL GATING FOR LOW-FREQUENCY SIGNALS.** It is possible to generate accurate counting intervals longer than 10 seconds by use of the manual-gating feature. This is especially useful for measurement of low-frequency signals. For example, if a 20-cps signal is measured with 10-second samples, the indicator will read 200 counts and the possible one-count error amounts to  $\pm 0.5\%$  of the measurement. If, however, a 100-second sampling time is used, the accuracy of the displayed 2000 is  $\pm 0.05\%$ .

To use manual gating, set the START-STOP button in the outer position, and the COUNTING TIME control to 10 SEC. After the counting has started but before 10 seconds has elapsed, turn the COUNTING TIME control to MANUAL, which blocks the instrument so that counting will not stop. To stop the count, return the COUNTING TIME control to 10 SEC and

the counting will stop on the next multiple of 10 seconds. For example, for a 100-second sampling interval, return the COUNTING TIME control to 10 SEC between 90 and 100 seconds after the start of the counting.

## 2.4 MANUAL TOTALIZING OPERATION.

For counting or totalizing operations, set the COUNTING TIME control to MANUAL and use the START-STOP button to start (outer position) and stop (inner position) the count. The DISPLAY TIME control is effective during manual operation. The RESET button is also operative, but use of this control while the instrument is counting can lead to a false count, especially for high-frequency signals. To clear the indicators, stop the count with the START-STOP control and then reset.

## 2.5 USE OF AN EXTERNAL REFERENCE SOURCE.

An external 100-kc signal can be used as a reference source in place of the 100-kc signal from the crystal oscillator of the Type 1150-A. Apply the signal to the EXT 100 KC INPUT phono jack at the rear of the instrument and set the TIME BASE switch to EXT. The external signal source should be capable of providing 0.3 volt across a 1-kilohm load.

## 2.6 CONNECTION TO ACCESSORY EQUIPMENT.

**2.6.1 INTERNAL OSCILLATOR SIGNAL.** At the INT 100 KC phono jack on the rear of the instrument, a high-impedance output from the very stable 100-kc crystal oscillator is available for driving accessory equipment.

**2.6.2 PHOTOELECTRIC PICKOFF.** A three-terminal telephone jack is provided on the rear of the instrument for direct connection to a General Radio Type 1536-A Photoelectric Transducer. The transducer has a light source and a photoconductor which convert changes in reflection of the light source into electrical input signals. For instance, when the transducer is placed in the path of a piece of reflecting tape on a rotating object, the frequency meter indicates revolutions per second. The photoelectric pickoff signal is in parallel with the INPUT terminals, so, for proper operation with the pickoff, no signal should be connected to the INPUT terminals.

**2.6.3 AUXILIARY EQUIPMENT.** A six-connector Jones-type socket (AUX) at the rear of the instrument is provided for connection to auxiliary equipment. Table 2-1 lists the signals available at this connector.

TABLE 2-1 AUXILIARY CONNECTIONS

Pin	Internal Signal	Output
1	Ground	0 volt.
2	Dc power supply	+20 v regulated, with less than 0.5 v of high-frequency ripple while the instrument is operating. Supplies up to 100 ma; however, even an instantaneous short to ground will cause failure of the regulating transistor (Q501) and/or opening of the fuses.
3	Negative pulse from highest-unit indicator ("spill-over" signal).	The output transfer pulse from the decade driving the highest-unit indicator (one furthest to the left). Should be capacitively coupled, if used. Overload can cause errors in instrument operation and a direct short may lead to permanent damage.
4	Connection for externally duplicating the RESET function	See Figure 2-6.
5	Connection for externally duplicating the START-STOP function	See Figure 2-7.
6	Positive reset pulse output	+15 volts except for approximately 4 msec when the output is +20 volts while the indicators clear. Overloading this terminal will cause instrument failure, and even a momentary direct short will cause permanent damage.

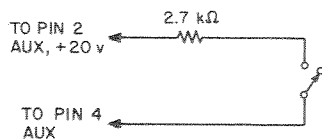

Figure 2-6. External connections which duplicate the function of the RESET button. Momentarily closing the normally open switch has the same effect as pressing the RESET button.

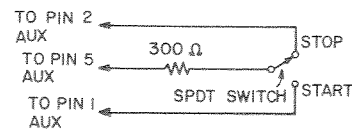

Figure 2-7. External connections which duplicate the function of the START-STOP button. Resistor R243 should be disconnected from switch S201 when this modification is made.



## SECTION 3

## PRINCIPLES OF OPERATION

## 3.1 GENERAL.

The Type 1150-A Digital Frequency Meter measures the frequency of an applied signal by comparing it with an accurate 100-kc signal generated within the instrument. The instrument compares the signals by counting the number of cycles of applied signal that occur during a time interval derived from the 100-kc signal. The displayed count is the frequency of the input signal in units of tens of cycles, cycles, or tenths of cycles, averaged over a selected counting interval of 0.1, 1.0, or 10 seconds, respectively. The circuits of the Type 1150-A provide, in addition to the counting interval, a display interval, and a reset interval to clear the indicators to zero. These three intervals follow each other sequentially and continuously.

Figure 3-1, a simplified block diagram, indicates the principal circuits of the instrument and the signal flow paths. The input amplifier, pulse-forming circuits, and the five ring counting units perform the counting operation. The input amplifier increases the instrument sensitivity and input impedance. The ring counting units are cascaded scale-of-ten circuits. Each unit is coupled to a Numerik indicator, which provides the digital display.

The main gate acts as a switch either to pass pulses (open gate) or to stop the flow of pulses (closed

gate). The gate is driven by the main-gate flip-flop. Time-base pulses from the time-base divider switch the flip-flop between its two stable states to open and close the main gate.

The 100-kc crystal-oscillator output is shaped into a pulse-type waveform to drive the time-base-divider circuits. The divider produces a train of pulses derived from the oscillator signal with a frequency of 10, 1 or 0.1 pulses per second as selected by the COUNTING TIME control. The pulse train is fed through the time-base gate to the main-gate flip-flop. (The time-base gate and time-base gate flip-flop operate in a manner similar to the main-gate flip-flop and main gate.) The time-base gate prevents a divider pulse from opening the main gate during the display-time interval.

A counting interval starts when the ring counting units have been reset, the time-base gate has opened, and a divider pulse arrives at the main-gate flip-flop to open the main gate. The counting interval ends when the next divider pulse is received. This pulse closes the main gate, starts the display interval by switching the time-base gate flip-flop to close the time-base gate, and activates the display-time generator. In this condition the divider pulses are locked out and the indicators display the measurement.

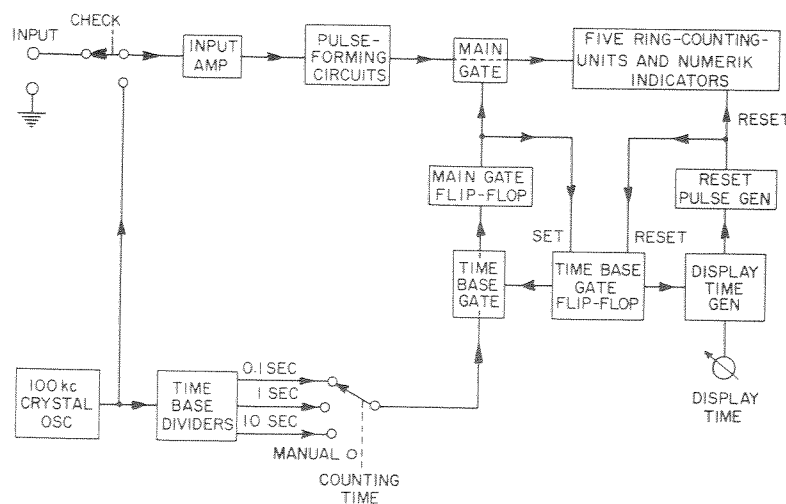

Figure 3-1. Simplified block diagram of the Type 1150-A Digital Frequency Meter.

After a time interval determined by the DISPLAY TIME control, the reset-pulse generator is triggered, and the ring counters are reset. The trailing edge of the reset pulse sets the time-base gate flip-flop to open the time-base gate. The next pulse from the divider starts another counting interval.

A detailed block diagram, Figure 4-2, shows the functional circuits of the instrument and etched-board locations of these circuits.

### 3.2 RING COUNTING UNITS.

Figure 3-2 is a simplified schematic of one of the five ring counting units used in the Type 1150-A Digital Frequency Meter. Each unit consists of a ring-of-ten bistable circuit. Each bistable circuit has one "high-current" transistor capable of driving the associated incandescent lamp for the Numerik indicator for that decade. The first ring counting unit differs from the other four only in the values of its components.

In Figure 3-2, assume that the counting unit has been set to its zero state. Q101 will be off and Q102, on. Q102 has its base forward bias current provided by R103 to keep it saturated and passing 80 ma to light the zero lamp in the indicator. This 80-ma current will produce a voltage rise of 5.5 volts across R101. The base of Q101 is returned via R102 to the set-zero buss voltage of about -5.0 volts. The base of Q101 is, therefore, reverse-biased with respect to the emitter and Q101 will remain off. The circuit is stable in this state.

All other pairs in the ring will have the opposite stable state. The left-hand transistors (Q103, etc), and all saturated right-hand transistors (Q104, etc), are off. When Q103, for example, is on the R105 clear buss (not the same -5.0-volt potential as the set-zero buss), it will have nearly 1 ma of forward drive. The drop across the 68-ohm resistor (R104) on the common emitter will be only 0.07 volt and the full 20-volt collector-supply voltage will appear across R106. The very small drop in emitter-to-collector voltage of Q103 will normally be below the conduction knee-voltage of Q104 and will keep it off. Complete cutoff of Q104 for all possible transistor combinations at elevated temperature is ensured by the silicon diode (CR103 in series with the emitter of D104).

The input signal advances the state of the decade by one stage per pulse. A negative pulse is applied to the base of the advance chain Q121, turning it off. The on-lamp chain Q102 loses base forward drive and goes off. The common-emitter voltage rises from -5.5 volts to 0 and Q101 goes on. The positive pulse at the common emitter is fed through C101, turning Q103 off and Q104 (the 1 driver) on. Each succeeding pulse applied to Q101 will advance the count by one digit. At the count of 10 the zero pair is switched to the initial conditions, and the negative pulse generated as the 9 lamp extinguishes is fed from this ring counting unit as a carry pulse to the advance driver of the succeeding unit.

In the simplified schematic diagram of Figure 3-2, the zero-set system is depicted as a switch for simplicity. When this switch is opened, the clear buss will return to -20 volts, causing all the left-hand transistors of the bistable circuits to saturate, turning the lamp drives for 1 through 9 off. Q101, on the

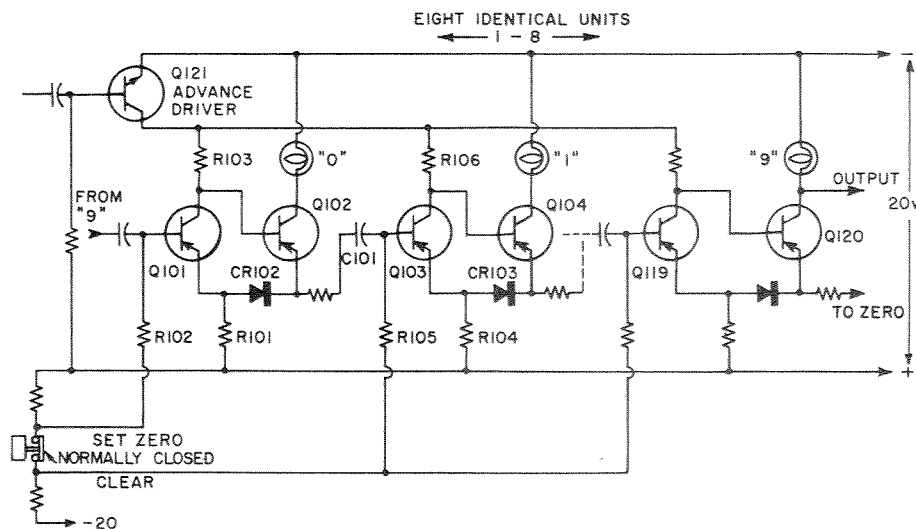

Figure 3-2. Elementary schematic diagram of a typical ring counting unit.



other hand, will lose forward bias, desaturate, and permit Q102 to go on, thereby turning on the zero lamp. A fast transistor switch is used in the Type 1150-A to zero set all five ring counting units.

### 3.3 INPUT AMPLIFIER.

The input amplifier in the Type 1150-A Digital Frequency Meter is a two-transistor feedback amplifier with a voltage gain of 10. The base and the emitter of the input transistor (Q301, Figure 4-6) are biased to approximately 7 volts by resistors R302 and R303. The total operating current for both transistors is determined by R308 in series with R309. The division of current between the transistors is determined by the ratio of R305 to R306. To obtain a high input resistance, the shield of the input cable and the biasing resistors are bootstrapped by capacitor C302. The input resistance of the amplifier is typically 800 k $\Omega$  and is determined largely by the collector resistance of Q301.

The amplifier is connected to the input terminals in parallel with the photoelectric-pickoff terminals located at the rear of the instrument when the CHECK switch (S301) is in the position closer to the panel. When the CHECK switch is in the position farther out from the panel, the amplifier is connected to the 100-kc internal crystal oscillator.

### 3.4 PROGRAM CIRCUITS.

**3.4.1 SCHMITT CIRCUIT.** Transistors Q201 and Q202 (Figure 4-5) are regeneratively connected to form a Schmitt circuit to generate a pulse-type output waveform from the amplified input signal. The output signal at the collector of Q202 has a rectangularly shaped waveform of approximately 4-volt amplitude and 0.5- $\mu$ sec rise time.

**3.4.2 PULSE SHAPER.** Transistor Q203, which is normally biased to saturation, forms a negative pulse with approximately 1- $\mu$ sec duration. The base of Q203 is capacitively coupled to the output of the Schmitt circuit by capacitors C202 and C203 in parallel. Following negative transitions of the Schmitt circuit, the coupling capacitors are charged through the relatively low impedance of the saturated pulse-shaping transistor. Positive transients of the Schmitt-circuit output waveform cause Q203 to become reverse-biased. The length of cutoff time for Q203 is determined by the discharged time constant of the coupling capacitor and R206. The cut-off time, hence pulse duration, is adjusted with C203. Diode CR201 protects transistor Q203 from excessive reverse bias.

**3.4.3 MAIN GATE.** Transistors Q204 and Q205 form a series-type gating circuit. The gating signal of approximately 20-volt amplitude (A. T. 203)\* is applied to transistor Q204 through biasing resistors. A positive gating signal at A. T. 203 holds Q203 reverse-biased and essentially disconnects the emitter of Q205 so that no signal is amplified by Q205. When the gating signal is approximately at ground, Q204 is biased into conduction and Q205 amplifies and inverts the pulses coming from the pulse-shaping transistor Q203. While the main gate is conducting (open), the output signal of transistor Q205 (A. T. 202) consists of positive pulses of approximately 1- $\mu$ sec duration and 20-volt amplitude. The nonconducting (closed) gate output signal should be 0.25 volt or less.

**3.4.4 TIME-BASE GATE.** The time-base gating transistor Q206 is driven from the collector of Q211, which is either at 19 volts or at 2 volts above ground. For the 19-volt drive, Q206 has both junctions reverse-biased and acts as an open circuit. For 2-volt drive, the positive pulses from the time-base divider (A. T. 206) saturate Q206 and appear at its collector with very little attenuation.

**3.4.5 MAIN GATE FLIP-FLOP.** Transistors Q207 and Q208 form a conventional saturating flip-flop circuit. Input pulse steering is provided by CR202, CR303, R218, and R219. A low-impedance source of 0.6 volt for hold-off bias is provided by silicon rectifier C204. Capacitor C208 couples the pulse output of the display-time generator to the main-gate flip-flop and ensures that the main gate is closed during the display interval.

**3.4.6 TIME-BASE GATE FLIP-FLOP.** Transistors Q210 and Q211 form a conventional saturating flip-flop circuit. The positive transition of the gating waveform (A. T. 203) is coupled via capacitor C209 to the base of Q210 which puts Q210 in a nonconducting state and Q211 into a conducting state. The positive transition of the reset pulse is coupled via capacitor C210 to the base of transistor Q211 and puts Q211 in a nonconducting state and transistor Q210 into a conducting state.

**3.4.7 DISPLAY-TIME GENERATOR.** Unijunction transistor Q212 is a delay generator which sets the display time. When Q211 is saturated, capacitor C213 charges through R229 and a display-time control R230. The voltage across C213 (A. T. 208) exponentially approaches +20 volts. At the unijunction firing voltage of approximately 10 volts, a near short circuit is developed between the emitter and base 1 of Q212 which rapidly discharges C213. The pulse generated across R233 has a fast rise time, 8-volt amplitude, and approximately 70- $\mu$ sec total duration.

\*A. T. refers to an anchor terminal indicated on the circuit diagram.

When the RESET button (S203) is pressed, the display-time generator produces an output pulse by charging C213 through R231. The integrating effect of charging C213 eliminates multiple pulses due to bouncing of the RESET button.

**3.4.8 RESET PULSE GENERATOR AND AMPLIFIER.** Transistors Q213 and Q214 form a saturating monostable multivibrator. Transistor Q214 is normally biased off and Q213 is biased to saturation by R237. A positive pulse coupled from the display-time generator by C216 causes Q213 to turn off. Q214 is regeneratively driven into conduction for a period of time determined by coupling capacitor C215 and resistor R237. A positive pulse of approximately 12-volt amplitude and 17-msec duration is generated at the collector of Q214.

The monostable circuit normally holds Q216 reverse-biased, with Q215 forward-biased to saturation with a collector-to-emitter drop of only a few tenths of a volt. The output voltage at the reset terminals (A.T. 209 and 210) is, therefore, formed by the voltage divider R241 and R242. This voltage should be  $15 \pm 1$  volts above ground. When the monostable circuit is not in its normal state, transistor Q215 is reverse-biased, which allows the set-zero line (A.T. 209) to rise to approximately 19 volts, and transistor Q216 is biased on to saturation which forces the reset buss voltage (A.T. 210) to drop to approximately ground.

**3.5 TIME BASE.**

**3.5.1 CRYSTAL OSCILLATOR.** Figure 3-3 is an elementary circuit diagram of the 100-kc crystal oscillator in the Type 1150-A Digital Frequency Meter. Transistors Q505 and Q506 provide the gain and the proper terminal impedance for the modified-Pierce crystal oscillator. All of the 60-db, open-loop gain of this transistor pair is used as negative feedback. This results in very stable circuit gain with

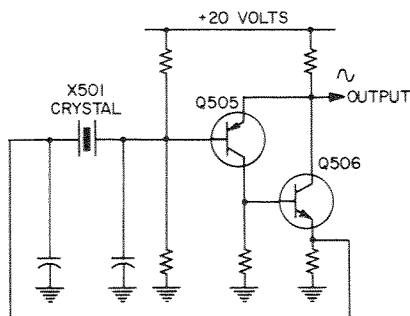

Figure 3-3. Simplified circuit diagram of the 100-kc crystal oscillator used in the Type 1150-A Digital Frequency Meter.

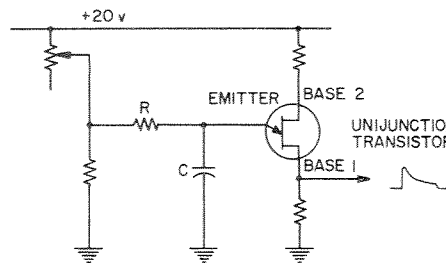

Figure 3-4. Circuit diagram of a relaxation oscillator with a unijunction transistor.

respect to temperature, voltage, and transistor-parameter variations, and hence, excellent oscillator-frequency stability. The oscillator crystal (X501) is held at constant temperature in a small oven with a hermetically sealed thermostat.

With the TIME BASE switch (S502) set at INT (refer to Figure 4-10), the oscillator output is fed to the buffer amplifier (Q507). For the EXT position of the TIME BASE switch, the buffer amplifier is connected to the EXT 100 KC INPUT connector (J501, at the rear of the instrument) and an externally generated 100-kc signal can be fed into the time base of the Frequency Meter. Diodes CR505 and CR506 protect the buffer amplifier (Q507) against excessive drive and transients. The buffer amplifier (Q507) feeds the 100-kc signal to the time-base divider, to the CHECK switch (S301) for self-check operation, and to the INT 100 kc connector (J502) for calibration or for driving external circuitry.

**3.5.2 TIME-BASE DIVIDERS.** Five frequency dividers provide the standard gate times of 0.1, 1, and 10 seconds in the Type 1150-A Digital Frequency Meter. The dividers use unijunction transistors in synchronized stable relaxation oscillators (see Figure 3-4). The unijunction transistor, or double-base diode, is a silicon unit which will "breakdown" and conduct heavily between emitter and base 1 when the emitter reaches a specified potential (about one-half the supply voltage) with respect to base 1. Before breakdown, the emitter presents a very high resistance to the timing circuit. After breakdown, a high current passes between emitter and base 1, discharging the timing capacitor. When this discharge current reaches a small value, the breakdown condition ends and the timing capacitor begins to recharge toward the supply voltage. The supply voltage to which the upper base is referred is modulated by the input synchronizing pulses. Breakdown is therefore determined by the combination of the rising emitter voltage and the falling synchronizing voltage.<sup>1</sup>

<sup>1</sup>General Electric Transistor Manual, 1960, pages 138-145.



In the Type 1150-A Digital Frequency Meter, the emitter output of each unijunction transistor is a sawtooth waveform of approximately 10-volt amplitude. The waveform at the lower base (test points 401 through 405) is a brief positive pulse. Buffer transistors between the dividers are saturated by this pulse and produce a negative synchronizing pulse for the succeeding stage.

The first divider stage divides the 100-kc oscillator signal by 40 to 2.5 kc; the second stage divides by 25 to 100 cps; the three following circuits each divide by 10 to produce outputs at 10, 1, and 0.1 cps. The high order of division in the first two circuits is possible through careful selection of circuit components and unijunction transistors. Individual temperature compensation is also provided in the first divider. The unijunction transistors in the five dividers are color-coded and should be not interchanged.

### 3.6 POWER SUPPLIES.

A single regulated dc source of +20 volts, with respect to chassis ground, is used for all circuits in the Type 1150-A Digital Frequency Meter. A series-

type electronic regulator is used for both dc voltage control and for ripple reduction. A portion of the output voltage (determined by the voltage divider, R509, R510, and R511 of Figure 4-10) is compared with a fixed reference voltage (determined by Zener diode CR504) in a differential amplifier (Q503 and Q504). If the output voltage increases, the current in Q504 also increases which decreases the current in Q503. In turn, Q503 reduces the base current in the emitter-follower (Q502) and in the series transistor (Q501), which reduces the output voltage.

Diode CR503 with resistors R504 and R505 supplies the base forward drive for Q503 when power is first applied. As soon as the voltage across CR504 approaches its normal value, CR503 becomes reverse-biased and disconnects the starting circuits.

With the POWER switch in the OFF position, the unregulated power from the +20-volt supply is disconnected and the cooling fan is off. The power transformer primary winding is, however, still powered, so that the crystal oven is on and crystal temperature is maintained as long as the instrument is plugged into the power line.

## SECTION 4

## SERVICE AND MAINTENANCE

### 4.1 GENERAL.

We warrant that each new instrument sold by us is free from defects in material and workmanship and that properly used it will perform in full accordance with applicable specifications for a period of two years after original shipment. Any instrument or component that is found within the two-year period not to meet these standards after examination by our factory, district office, or authorized repair agency personnel will be repaired or, at our option, replaced without charge, except for tubes or batteries that have given normal service.

The two-year warranty stated above attests the quality of materials and workmanship in our products. When difficulties do occur, our service engineers will assist in any way possible. If the difficulty cannot be eliminated by use of the following service instructions, please write or phone our Service Department (see rear cover), giving full information of the trouble

and of steps taken to remedy it. Be sure to mention the serial and type numbers of the instrument.

The Type 1150-A features a modular construction that greatly simplifies repair. Transistors are on etched boards easily removable from the main structure. To keep "down time" to a minimum, the user can replace a defective board immediately, thus keeping the counter in use while the defective board is being repaired.

Before returning an instrument to General Radio for service, please write to our Service Department or nearest district office (see back cover), requesting a Returned Material Tag. Use of this tag will ensure proper handling and identification. For instruments not covered by the warranty, a purchase order should be forwarded to avoid unnecessary delay.

Components not mounted on etched boards include front-panel controls and switches, indicators, plugs, sockets, power-supply regulating transistor and rectifier diodes, and the power transformer.

## 4.2 ROUTINE MAINTENANCE.

**4.2.1 REPLACING THE INDICATOR LAMPS.** Burned-out (open-circuited) lamps will cause a failure in the counting process. To determine the indicator that contains an open lamp, set the CHECK switch to the position further out from the panel and set the COUNTING TIME switch to 1.0 SEC. The ring counting units will operate properly until the open-lamp circuit is energized. That indicator will not display a number and the succeeding indicators will remain at zero. At the end of the counting interval, the faulty indicator will not display a number. To locate which one of the ten bulbs in this indicator is open, either unplug the etched-circuit board for the corresponding ring counting unit and with an ohmmeter check the continuity between the socket pins and the chassis, or apply a low-frequency input signal and observe the counting operation noting the numeral where counting stops.

To gain access to the lamps, turn off the power to avoid shorting the connecting terminals to the chassis, turn the two knurled panel screws on either side of the indicator bank a quarter turn counterclockwise, and pull the indicator bank from the instrument. Eight spare indicator bulbs are provided in the front panel and are accessible when the indicator bank is removed. To remove a burned-out bulb, remove the two screws at the rear of the faulty indicator.

The probability of failure for incandescent bulbs is a function of their operating time. Very few bulbs will have to be replaced until the instrument has accumulated several thousand hours of use, and then the rate of replacement will increase rapidly. We recommend that all bulbs be replaced when this increase is noted (typically after 5000 hours of use). You will notice that used bulbs have darkened due to condensation of filament material on the inside of the glass envelope and may not provide sufficient illumination if continued in use.

The lamps supplied in the Type 1150-A Digital Frequency Meter are General Electric Type 330 or the equivalent. Replacement bulbs should have approximately 0.5 candlepower at 14 volts and 0.08 ampere.

**4.2.2 CLEANING THE AIR FILTER.** To maintain proper cooling efficiency, the air filter should be cleaned periodically. Local air conditions determine how often this is necessary. To clean, remove the air filter from its holder, rap gently to remove excess dirt, flush from the dirty side with hot soapy water, rinse, and let dry. Commercially available preparations to increase the filtering efficiency may be applied but are not necessary.

**4.2.3 LUBRICATING THE FAN MOTOR.** For long, trouble-free operation, lubricate the fan motor at least once a year with SAE 20 or 30 premium-quality oil. There are two lubricating holes, one in each of the brass brackets on either side of the motor laminations.

**4.2.4 CHECKING THE 100-KC CRYSTAL-OSCILLATOR FREQUENCY.** The accuracy of the frequency measurements made with the Type 1150-A depends on the frequency accuracy of the crystal oscillator. This oscillator is very stable and should rarely require resetting. To check the oscillator frequency, observe the signal at the INT 100 KC connector at the rear of the instrument with a General Radio Type 1130-A Digital Time and Frequency Meter, or use a beat method with a stable 100-kc standard frequency signal. For the comparison method, use a signal whose frequency is known to at least one part in  $10^5$  and preferably 1/2 part in  $10^6$ .

Although the power-line frequency can be measured to considerable accuracy ( $\pm 0.017\%$  for a 100-second average taken by manual multiple-period gating; refer to paragraph 2.2.2), it should not be used to set the accuracy of the Frequency Meter, since the power-line frequency varies in the course of a day (typically  $\pm 0.1\%$ ).

To adjust the 100-kc oscillator frequency, turn the variable air capacitor located near the INT 100 KC plug (accessible when the instrument cabinet is removed; refer to paragraph 2.2.2).

## 4.3 INTERNAL ADJUSTMENTS.

**4.3.1 GENERAL.** Normally, most of the factory-set adjustments will not require any attention. Those adjustments that may occasionally be necessary (as, for instance, after replacement of a transistor) are described in the following paragraphs. Before making these adjustments, be sure that the TIME BASE switch is set to INT and that the power-supply and input-signal characteristics are correct (refer to paragraphs 2.2.4 and 2.2.7).

**4.3.2 POWER-SUPPLY ADJUSTMENT.** The trimmer potentiometer, R510, located on the power-supply board, adjusts the regulated 20-volt dc supply. The voltage between anchor terminal 507 and ground should be set to within 5% of 20 volts.

**4.3.3 ADJUSTMENT OF THE DURATION OF THE FIRST-COUNTING-UNIT INPUT PULSE.** Apply a 220-kc signal to the INPUT terminals. Adjust the duration of the input pulse with the small ceramic trimmer



capacitor, C203, located on the horizontally mounted program board. Set C203 to the middle of the range for which the instrument properly indicates 220 kc. This adjustment is not critical.

**4.3.4 ALIGNMENT OF THE TIME-BASE DIVIDER BOARD.** The time-base divider board (Type 1150-4040) consists of five RC oscillators, which are locked to each other in chain fashion and which divide the 100-kc crystal-oscillator signal for the 10-, 1-, and 0.1-cps outputs. The oscillators are carefully aligned at the factory and should not be adjusted unless there is a positive indication of error in division ratio. An error in oscillator alignment will be indicated by an incorrect reading when the Type 1150-A is operated with the CHECK switch in the position further out from the panel. The adjusting potentiometer and unijunction transistor associated with each oscillator are listed in Table 4-1 and identified in Figure 4-1. In Figure 4-1 the transistors have been removed from their sockets.

The unijunction transistors installed at the factory have been selected for proper temperature coefficient and have been color-coded with their corresponding sockets. Be sure that the unijunction transistors supplied are not interchanged in the oscillators. An unselected unijunction transistor should operate satisfactorily for the range of temperatures encountered in most installations.

An error in the dividers can be observed with an oscilloscope or frequency meter by comparing the input and output pulse repetition rates.

To adjust the oscillators, adjust the trimming potentiometers to their free-running frequencies (refer to Table 4-1) with an instrument such as the General Radio Type 1130-A Digital Time and Frequency Meter. The oscillator is made free-running when the unijunction transistor of the next higher divider is unplugged. The 2.5-kc oscillator is made free-running when the TIME BASE switch is set to EXT.

**4.4 TROUBLE-SHOOTING PROCEDURE.**

The simplest method of locating a malfunction within the instrument is to observe the indicator readings and the COUNTING lamp while operating the panel controls. Section 3, Principles of Operation, and Figure 3-1, the block diagram, will help determine which circuits are used for the various positions of the panel controls. The schematic diagrams, parts lists, part-locating drawings, voltage tables, and waveforms are given at the end of this section.

**CAUTION**

When trouble-shooting, be careful to avoid short-circuits, between components and chassis, connectors, etc. In some cases, even a momentary short-circuit can destroy a transistor.

Table 4-2 (page 16) lists possible failures and their probable causes.

**TABLE 4-1**

Unijunction Transistor	Division Ratio	Adjustment Potentiometer	Locked Output Frequency	Unlocked (Free-Running) Period
Q401	40:1	R401	2.5 kc	405 μsec
Q403	25:1	R408	100 cps	10.2 msec
Q405	10:1	R414	10 cps	105 msec
Q407	10:1	R427	1 cps	1.05 sec
Q409	10:1	R428	0.1 cps	10.5 sec

TABLE 4-2

Symptom	Probable Cause	Procedure	Note
Indicator lamps do not light and fan does not operate.	Open fuse.	Check fuses and replace any that are burned out.	If the applied input signal has a frequency considerably higher than the 220-kc maximum rating, more than one bulb may light, causing a power-supply overload. If this condition persists for more than a few seconds, a fuse may open.
COUNTING lamp operates properly, but one indicator does not display a number.	Burned-out indicator lamp.	Replace the burned-out lamp (refer to paragraph 4.2.1).	
Frequency indication is in error and no count is displayed for self-check operation.	No external 100-kc signal is applied with the TIME BASE switch set to EXT.	Set the TIME BASE switch to INT.	
COUNTING lamp does not light except for MANUAL setting of COUNTING TIME switch.	Loss of time-base divider pulses.	Check for proper waveforms in time-base divider board (see Figure 4-9).	
COUNTING lamp does not light for any setting of COUNTING TIME switch.	Failure in main-gate flip-flop and lamp-driver circuits.	Check for proper waveforms and in program control board voltages (see Figure 4-5).	
COUNTING lamp does not light, but instrument makes correct measurements.	Failure in lamp-driver circuits or burned-out lamp in COUNTING indicator.	Refer to Figure 4-5.	
Instrument makes one sequence of operations each time the RESET button is pressed, but will not measure automatically.	Failure of display-time generator and/or time-base gate flip-flop.	Check for proper waveforms and voltages at Q212 and associated components (see Figure 4-5).	
COUNTING lamp operates properly, but no count is registered.	Failure in input amplifier, Schmitt circuit, or main gate.	Check for proper waveforms and voltages, Figures 4-5 and 4-6.	
Indicators do not reset to zero and do not register a count when the COUNTING lamp is off.	Failure in reset-pulse generator.	Check dc voltages at reset-pulse and clear-pulse output terminals (A.T. 209 and A.T.208).	
Counting starts automatically, but immediately stops.	Abnormally short counting interval often caused when reset-pulse generator triggers on noise.	Check width of transfer pulse to the first counting unit (refer to paragraph 4.3.3).	If the first counting-unit transfer-pulse width is set improperly, it may light more than one lamp in the first indicator and this multiple state may propagate to the following units. The resulting overload on the power supply causes its regulated voltage to drop. This change in supply voltage can cause the reset generator to produce a reset pulse.
Indicator displays have noticeably higher intensity than usual, and measurements are incorrect	Shorted regulating transistor, Q501.	Measure collector-to-emitter voltage across Q501. It should be between 2 and 9 volts, depending on the line voltage.	B+ will be 25 or 30 volts if Q501 is shorted.

## PARTS LISTS AND SCHEMATICS

*On the following pages appear parts lists, schematic diagrams, voltage tables, waveforms and etched-board layouts, which should prove helpful in trouble-shooting. These data are arranged by circuit as follows:*

<i>Circuit</i>	<i>Pages</i>
<i>Type 1150-A Block Diagram and Interior View . . . . .</i>	<i>19</i>
<i>Type 1150-4020 Program Control Circuit . . . . .</i>	<i>20, 21</i>
<i>Type 1150-4030 Input Amplifier Circuit . . . . .</i>	<i>23</i>
<i>Type 1150-4040 Time-Base Divider Circuit . . . . .</i>	<i>25</i>
<i>Type 1150-4050 Power Supply and Oscillator Circuits . . . . .</i>	<i>26, 27</i>
<i>Type 1150-D1 220-kc Ring Counting Unit . . . . .</i>	<i>28, 29</i>
<i>Type 1150-D2 30-kc Ring Counting Unit . . . . .</i>	<i>30, 31</i>
<i>Type 1150-A Interconnection Diagram . . . . .</i>	<i>32</i>

---

## NOTES FOR PARTS LISTS

*Type designations for resistors and capacitors are as follows:*

<i>COA - Capacitor, air</i>	<i>POSW - Potentiometer, wire-wound</i>
<i>COC - Capacitor, ceramic</i>	<i>REC - Resistor, composition</i>
<i>COE - Capacitor, electrolytic</i>	<i>REF - Resistor, film</i>
<i>COM - Capacitor, mica</i>	<i>REPR - Resistor, precision</i>
<i>COP - Capacitor, plastic</i>	<i>REW - Resistor, wire-wound</i>
<i>COT - Capacitor, trimmer</i>	

*Resistors ½ watt unless otherwise specified.*

*All resistances are in ohms, unless otherwise indicated by k (kilohms) or M (megohms).*

*All capacitances are in picofarads, unless otherwise indicated by  $\mu$ f (microfarads).*

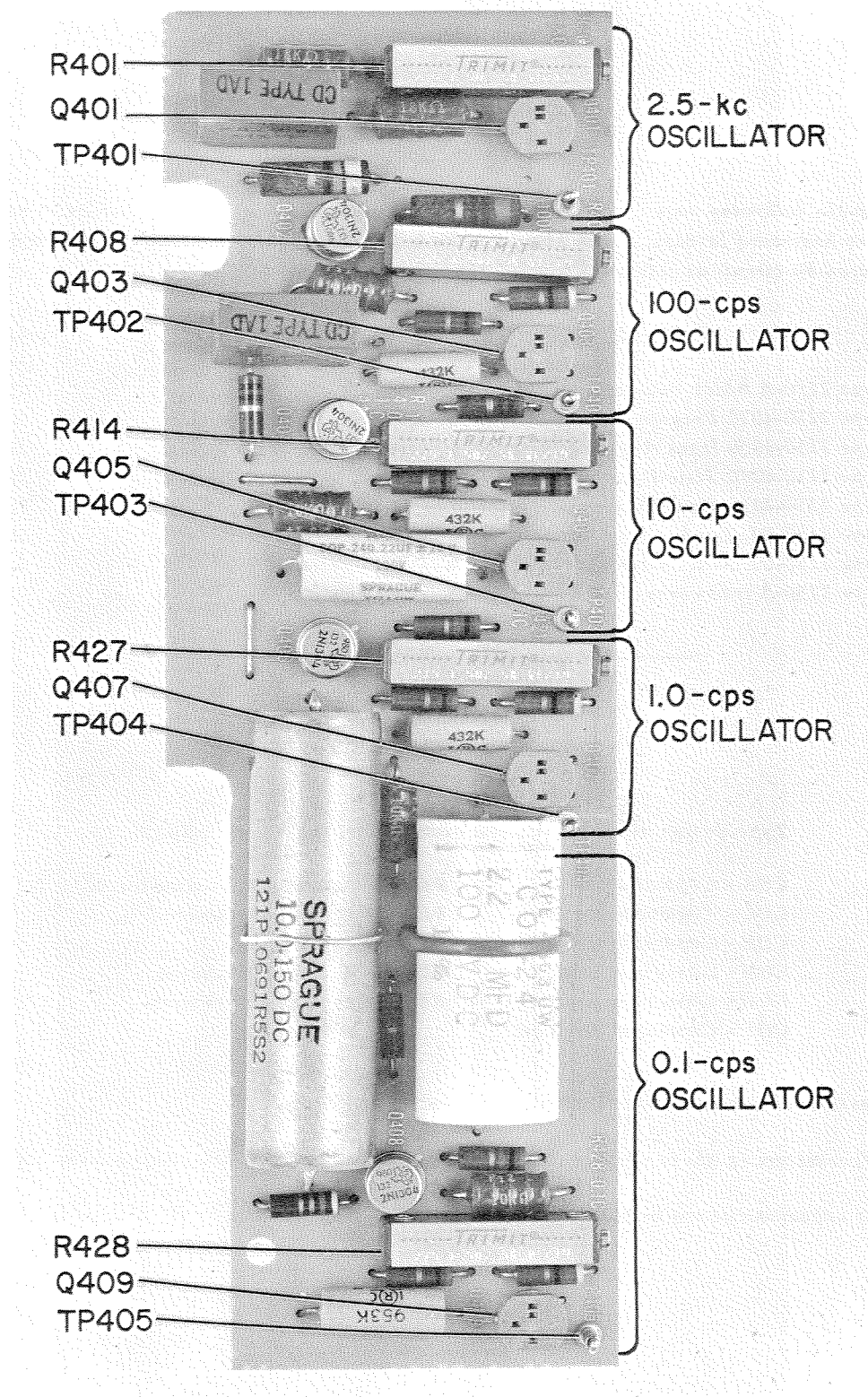

Figure 4-1. Time-base divider etched board used in the Digital Frequency Meter.