

Instruction Book

115-Volt and 230-Volt Models

30K-5

GROUND STATION TRANSMITTER

COLLINS RADIO COMPANY

Cedar Rapids, Iowa

NEW YORK

BURBANK

DALLAS

520 5354 00

1 DECEMBER 1955

Revised December 1956

Printed in the United States of America

GUARANTEE

The equipment described herein is sold under the following guarantee:

Collins agrees to repair or replace, without charge, any equipment, parts, or accessories which are defective as to design, workmanship or material, and which are returned to Collins at its factory, transportation prepaid, provided

- (a) Notice of the claimed defect is given Collins within one (1) year from date of delivery and goods are returned in accordance with Collins' instructions.
- (b) Equipment, accessories, tubes, and batteries not manufactured by Collins or from Collins' designs are subject to only such adjustments as Collins may obtain from the supplier thereof.
- (c) No equipment or accessory shall be deemed to be defective if, due to exposure or excessive moisture in the atmosphere or otherwise after delivery, it shall fail to operate in a normal or proper manner.

Collins further guarantees that any radio transmitter described herein will deliver full radio frequency power output at the antenna lead when connected to a suitable load, but such guarantee shall not be construed as a guarantee of any definite coverage or range of said apparatus.

The guarantee of these paragraphs is void if equipment is altered or repaired by others than Collins or its authorized service center.

No other warranties, expressed or implied, shall be applicable to any equipment sold hereunder, and the foregoing shall constitute the Buyer's sole right and remedy under the agreements in this paragraph contained. In no event shall Collins have any liability for consequential damages, or for loss, damage or expense directly or indirectly arising from the use of the products, or any inability to use them either separately or in combination with other equipment or materials, or from any other cause.

HOW TO RETURN MATERIAL OR EQUIPMENT. If, for any reason, you should wish to return material or equipment, whether under the guarantee or otherwise, you should notify us, giving full particulars including the details listed below, insofar as applicable. If the item is thought to be defective, such notice must give full information as to nature of defect and identification (including part number if possible) of part considered defective. (With respect to tubes we suggest that your adjustments can be speeded up if you give notice of defect directly to the tube manufacturer.) Upon receipt of such notice, Collins will promptly advise you respecting the return. Failure to secure our advice prior to the forwarding of the goods or failure to provide full particulars may cause unnecessary delay in handling of your returned merchandise.

ADDRESS:

Collins Radio Company
Sales Service Department
Cedar Rapids, Iowa

INFORMATION NEEDED:

- (A) Type number, name, and serial number of equipment
- (B) Date of delivery of equipment
- (C) Date placed in service
- (D) Number of hours of service
- (E) Nature of trouble
- (F) Cause of trouble if known
- (G) Part number (9 or 10 digit number) and name of part thought to be causing trouble
- (H) Item or symbol number of same obtained from parts list or schematic
- (I) Collins' number (and name) of unit sub-assemblies involved in trouble
- (J) Remarks

HOW TO ORDER REPLACEMENT PARTS. When ordering replacement parts, you should direct your order as indicated below and furnish the following information insofar as applicable. To enable us to give you better replacement service, please be sure to give us complete information.

ADDRESS:

Collins Radio Company
Sales Service Department
Cedar Rapids, Iowa

INFORMATION NEEDED:

- (A) Quantity required
- (B) Collins' part number (9 or 10 digit number) and description
- (C) Item or symbol number obtained from parts list or schematic
- (D) Collins' type number, name, and serial number of principal equipment
- (E) Unit sub-assembly number (where applicable)

TABLE OF CONTENTS

SECTION 1 - GENERAL DESCRIPTION

<u>Paragraph</u>		<u>Page</u>
1.1.	General	1-1
1.1.3.	Equipment Description	1-1
1.2.	Reference Data.	1-2
1.3.	Custom Modifications	1-9

SECTION 2 - INSTALLATION

2.1.	Installation	2-1
2.1.2.	Preliminary	2-1
2.1.3.	Installation Procedure	2-1
2.2.	Conversion to 115-V Operation	2-17
2.3.	Conversion to Frequency Shift Keying	2-17

SECTION 3 - ADJUSTMENT AND OPERATION

3.1.	General	3-1
3.1.1.	Filament, On-Off Switch	3-1
3.1.2.	Plate, On-Off Switch	3-1
3.1.3.	Filament Voltage Adjustment	3-1
3.1.4.	Plate Voltage Control	3-1
3.1.5.	Phone CW Selector Switch.	3-1
3.1.6.	Test Key.	3-1
3.1.7.	Channel Switch	3-2
3.1.8.	Local-Remote Control Switch	3-2
3.1.9.	Oscillator Plate Tuning	3-2
3.1.10.	Multiplier Plate Tuning	3-2
3.1.11.	Antenna Tuning and Loading	3-2
3.1.12.	PA Plate Tuning	3-2
3.1.13.	Audio Gain	3-2
3.2.	Energizing the Equipment for the First Time	3-2
3.2.1.	Precautions	3-2
3.3.	Adjustment Procedures	3-2
3.3.1.	RF Adjustment	3-2
3.3.2.	Voice Operation Adjustments	3-4
3.4.	Typical Meter Readings	3-6
3.4.1.	Phone Emission	3-6
3.4.2.	CW Emission	3-6

SECTION 4 - CIRCUIT DESCRIPTION

4.1.	General	4-1
4.2.	Primary Power Circuits	4-1
4.2.1.	Rectifier Power System	4-1
4.3.	Carrier Control Circuits	4-1
4.4.	RF Circuits	4-2
4.4.1.	Oscillator	4-2
4.4.2.	Multiplier	4-2
4.4.3.	RF Power Amplifier.	4-2
4.4.4.	RF Output Circuit	4-2

TABLE OF CONTENTS (Cont)

<u>Paragraph</u>		<u>Page</u>
4.5.	Audio Circuits.	4-2
4.5.1.	General	4-2
4.5.2.	Speech Amplifier Circuits :	4-2
4.5.3.	Modulator Driver Circuits	4-5
4.5.4.	Modulator Circuit	4-5

SECTION 5 - MAINTENANCE

5.1.	Routine Inspection Schedules.	5-1
5.1.1.	Cleaning.	5-1
5.1.2.	Vacuum Tubes.	5-1
5.1.3.	Relays.	5-2
5.2.	Trouble Shooting.	5-2
5.2.1.	General	5-2
5.2.2.	Isolating the Trouble	5-3
5.2.3.	Power Supply Trouble.	5-3
5.2.4.	Radio Frequency Trouble	5-5
5.2.5.	Audio System Troubles	5-5
5.3.	Replacement of Parts.	5-5
5.4.	Crystal Data.	5-5

SECTION 6 - PARTS LIST

SECTION 7 - APPENDIX I, ANTENNAS WITH 52-OHM COAXIAL FEED LINES

7.1.	General Discussion.	7-1
7.2.	Antenna Details	7-1
7.3.	Transmission Line	7-1
7.4.	Test Information.	7-1
7.5.	Impedance Transforming Balun for Open Wire Line	7-3

LIST OF ILLUSTRATIONS

Figure	Title	Page
1-1	Type 30K-5 Transmitting Equipment.	iv
2-1	Type 30K-5 Transmitter Outline and Mounting Dimensions	2-3
2-2	Type 177L-2 Remote Control Unit Outline and Mounting Dimensions.	2-4
2-3	Unit Placement Photograph.	2-7
2-4	External Connections	2-10
2-5	Applicable Antenna Circuits.	2-11
2-6	Suggested Ground System.	2-12
2-7	Antenna Horn Gap	2-12
2-8	Antenna Change-Over Relay Circuits	2-13/2-14
2-9	30K-5 Conversion to 220-Volt Operation.	2-15/2-16
3-1	Control Functions.	3-0
4-1	Primary Power Circuit.	4-3
4-2	Carrier Control Circuits	4-3
4-3	Audio Peak Clipper Circuit	4-4
4-4	Clipper Waveform Illustration.	4-4
5-1	RF Output Network, Parts Arrangement - Top	5-7
5-2	RF Exciter, Amplifier and Output Network, Parts Arrangement - Front.	5-7
5-3	RF Exciter, Amplifier and Output Network, Parts Arrangement - Rear	5-8
5-4	RF Exciter, Amplifier and Output Network, Parts Arrangement - Bottom	5-8
5-5	Speech Amplifier and Modulator, Parts Arrangement - Top.	5-9
5-6	Speech Amplifier and Modulator, Parts Arrangement - Bottom	5-9
5-7	Low Voltage and Bias Power Supply, Parts Arrangement - Top	5-10
5-8	Low Voltage and Bias Power Supply, Parts Arrangement - Bottom.	5-10
5-9	High Voltage Rectifier and Filter, Parts Arrangement - Top	5-11
5-10	High Voltage Rectifier and Filter, Parts Arrangement - Bottom.	5-11
5-11	Type 175V-2 Relay Unit, Parts Arrangement - Top.	5-12
5-12	Type 175V-2 Relay Unit, Parts Arrangement - Bottom	5-12
5-13	Type 177L-2 Remote Control Unit, Parts Arrangement - Top	5-13
5-14	Type 177L-2 Remote Control Unit, Parts Arrangement - Bottom.	5-13
5-15	Type 30K-5 Transmitter, Complete Schematic (Shown Wired for 230-V Operation)	5-15/5-16
5-16	Type 30K-5 Transmitter Cabling Schematic, Wired for 115-V Operation.	5-17/5-18
5-17	Type 177L-2 Remote Control Schematic	5-19
7-1	Balun with Balanced Open Wire Line	7-2
7-2	Equivalent Circuit, 108.2 Ohms to Z_{01}	7-3
7-3	Open Wire Line Impedance Chart	7-5
7-4	Half-Wave Antenna with Quarter-Wave Balun.	7-6
7-5	Broadband Antenna with Quarter-Wave Balun.	7-7

LIST OF TABLES

Table	Title	Page
1-1	Equipment Supplied	1-2
1-2	Equipment Required But Not Included.	1-2
1-3	Accessories.	1-3
1-4	Specifications	1-4
1-5	Chart for Selecting Crystals, RF Inductors and RF Chokes	1-11
5-1	Resistance Measurements.	5-6

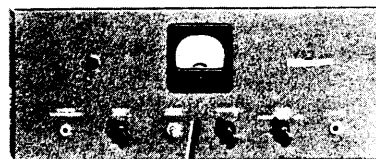
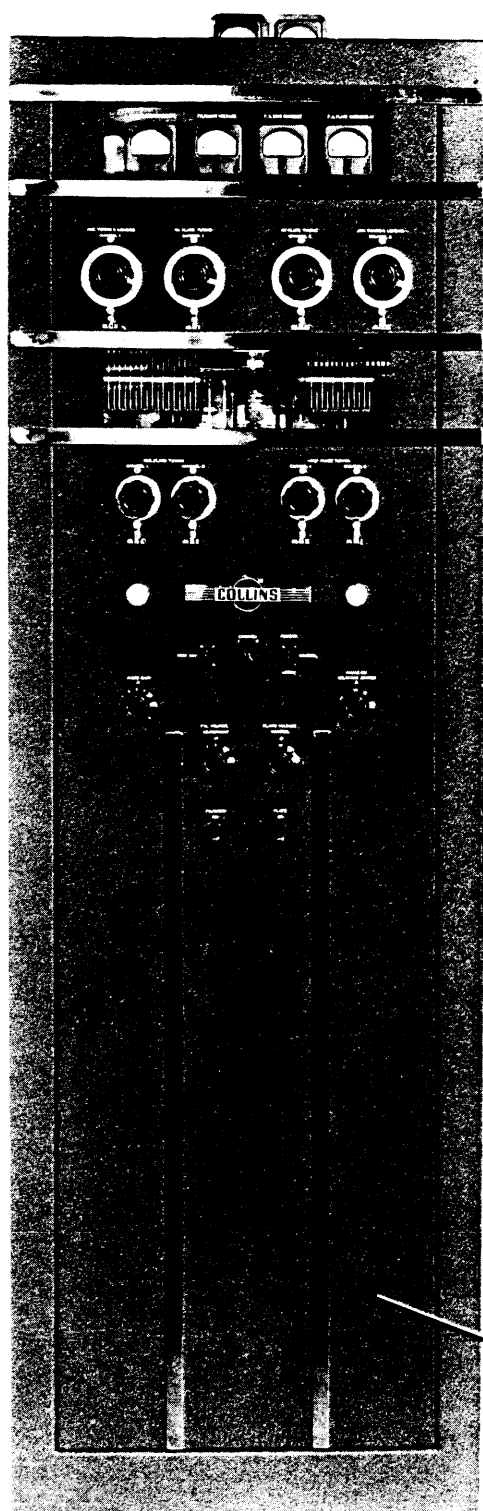

177L-2
REMOTE CONTROL
UNIT

30K-5
TRANSMITTER

Figure 1-1. Type 30K-5 Transmitting Equipment

SECTION 1

GENERAL DESCRIPTION

1.1. GENERAL.

1.1.1. This instruction book is intended to serve as a guide to the proper installation, adjustment, operation and maintenance of the Collins Type 30K-5 Ground Station Transmitter.

1.1.2. The type 30K-5 is a dual channel transmitter designed for general applications such as police service, aeronautical ground stations or general point-to-point communication, where service is intermittent. The adaptability of the transmitter is attested to by the wide frequency range and the flexible pi network output circuit arrangement, which permits the use of a variety of antenna types.

1.1.3. EQUIPMENT DESCRIPTION.

(a) The transmitter is completely self-contained except for microphone and key. It is housed in an attractive cabinet designed in accordance with the best principles of advance styling. It is built of heavy gauge steel employing a welded stiffener type of construction. The full length rear door provides access to all units. The component parts of each subunit are mounted on a removable chassis. All power and control wires between the subunits are laced together in a neatly formed cable. Connections are made at screw type, barrier, terminal strips at the rear of each unit.

The various chassis may be removed from the rear of the transmitter cabinet by first taking off the control knobs, removing the four bolts which secure the chassis to the mounting cleat, and disconnecting the cable from the terminal strip. A set of Bristo wrenches is fastened to the rear door for loosening set-screws in control knobs. A glass covered opening in the front panel allows a continuous check on the color of the plate of the power amplifier tube. The meter panel is also placed behind a glass covered opening in the interest of safety. The antenna current meters are located externally at the top rear edge of the transmitter cabinet. This feature allows shorter connecting leads, making possible more accurate current readings.

(b) ELECTRICAL - The stable oscillator circuit employs a type 6AG7 tube. An 807 follows the oscillator and serves as a buffer, doubler and driver. A type 4-125A high efficiency tetrode is used in the output stage. All r-f stages have dual tank circuits, one for each of the two pretuned frequencies. Relays connect the desired tuning elements into the circuit. Dual pi networks in the output stage are used for tuning the final amplifier and loading into the antenna. Only two controls, designated TUNING and LOADING are required for each network. Plug-in coils for r-f stages provide maximum efficiency at all frequencies, with a saving of space and operating controls.

The audio frequency response of 150-4000 cps is especially suited for voice communication. An audio peak clipping circuit is incorporated to improve the intelligibility when the atmospheric static level is high or when frequencies are congested. The clipper permits an unusually high level of modulation. The peak

power of vowel sounds is held at a low level; at the same time the consonant sounds, which provide intelligibility, are allowed to produce maximum power. The r-f carrier sideband power is greatly increased as compared to normal operation. The peak clipper also prevents overmodulation. A low pass audio filter follows the peak clipper thus attenuating audio frequencies above 4000 cps.

Remote operation can be provided by using the type 177L-2 Remote Control Unit. When the length of cable from the operating position to the transmitter is 50 feet or less, no additional equipment is required. However, for greater distances the type 177L-2 Remote Control Unit provides filament and plate power controls, keying, microphone preamplifier and channel switching functions. The output of the remote line is fed to standard telephone line. 2-1/2 pairs plus ground return are required. A db meter is incorporated in the remote control unit so the operator can control the speech level. The loss in the telephone line cannot exceed 25 db or the resistance of any wire with the ground return should not exceed 125 ohms. This represents approximately 2.8 miles for #19 GA telephone cable, 1.4 miles for #22 GA and 0.56 mile for #26 GA. For remote selection of type of emission (Phone or CW) one extra telephone wire is required.

The 230-V 30K-5 can be converted to 115-V operation by changing the "Tune" resistor and making a few simple wiring changes. (See paragraph 2.2)

1.2. REFERENCE DATA.

TABLE 1-1

•EQUIPMENT SUPPLIED

<u>Collins Type No.</u>	<u>Description</u>	<u>Over-all Dimensions (inches)</u>	<u>Weight (pounds)</u>
30K-5	Transmitter, Bristo wrenches, Phillips wrenches and screw-	22 W x 20 D 70 H.	385
522 0212 003 (230-V)	drivers, microphone connector.		
506 7722 002	Set of commercial type vacuum tubes		
520 5354 00	Instruction Book		

TABLE 1-2

EQUIPMENT REQUIRED BUT NOT INCLUDED

<u>Collins Type No.</u>	<u>Description</u>	<u>Over-all Dimensions (inches)</u>	<u>Weight (pounds)</u>
Select from 290 0876 00 thru 290 1075 00	Crystals		

TABLE 1-2 (Cont.)

<u>Collins Type No.</u>	<u>Description</u>	<u>Over-all Dimensions (inches)</u>	<u>Weight (pounds)</u>
506 6012 002	R-f tank inductor set		
503 3821 002 thru 503 3823 002	R-f choke set (part of 506 6012 002 tank inductor set).		
	Crystal or high impe- dance microphone.		
	Telegraph key and stand- ard 1/4" diameter phone plug.		
	Connection to power source (two #10 AWG or larger)		
	Antenna (s)		

TABLE 1-3

ACCESSORIES

<u>Collins Type No.</u>	<u>Description</u>	<u>Over-all Dimensions (inches)</u>	<u>Weight (pounds)</u>
175V-2 520 4574 00	Relay Unit		
177L-2 520 4575 00	Remote Control Unit	17-1/4" W, 7-7/16" D, 7" H	
505 5037 00	Fan Kit		
930 0035 00	Alternate C501 for use with 50 cps power source		
506 6012 00	Coil Set (according to frequency. See table 1-4).		
540 5962 002	230-V Conversion Kit (Used only to convert a 115-V transmitter to 230-V operation)		
542 0466 00 542 0467 00	} FSK Adapter Kit		

TABLE 1-4

SPECIFICATIONS

- a. Frequency Range: Output 2 to 30 mc. Two channels.
- b. Types of Emission: CW or AM.
- c. Power Output: (Nominal)
- | | <u>CW</u> | <u>AM</u> |
|-------------|-----------|-----------|
| 2 to 15 mc | 300 watts | 250 watts |
| 15 to 24 mc | 250 watts | 200 watts |
| 24 to 30 mc | 225 watts | 150 watts |
- d. Power Source: 230 volts, two wire, single phase, 60 cps. For 50 cps operation, an alternate capacitor is required. See table 1-3.
- e. Number and Type of Cabinets: Single, welded steel.
- f. Type of Mounting: Floor.
- g. Exterior Finish: St. James gray wrinkle.
- h. Type of Service: Attended, intermittent duty. Capable of continuous duty with accessory cooling fan. See table 1-3. For local or remote control using a type 175V-2 Relay Unit and a type 177L-2 Remote Control Unit as accessories. See table 1-3.
- i. Certification or Licensing Requirements: Data concerning this transmitter is filed with FCC.
- j. Ambient Temperature Range: 0 to +50° C.
- k. Ambient Humidity Range: 0 to 95% relative humidity.
- m. Altitude: Sea level to 6000 feet. Higher with 75% of nominal power output using low voltage taps on secondary of HV plate transformer.
- n. Shock Conditions and Vibration: Capable of withstanding handling and transportation.
- o. Audible Noise: Acoustic noise level measured 1 foot from the cabinet does not exceed 1 dyne per square cm.
- p. Enclosure: Single welded steel cabinet. For fixed operation in a building where it will not be exposed to the elements.
- q. Access: Full-length door at the rear, locked with removable key. Chassis mounted horizontally on rails for easy removal.

TABLE 1-4 (Cont.)

r. Location and Type of Connectors: All incoming wires except rf circuits are terminated inside the cabinet. Entrance through floor or through holes above floor level at rear or sides of cabinet. The key jack accepts a standard 1/4 dia phone plug. Microphone and push-to-talk connections are made with an Amphenol type MC 4M four-contact connector. Control wires and circuits between units are terminated on screw type terminal strips at rear of units. Rf circuits are terminated on insulated studs above the rear door.

s. Type of Ventilation: Convection. Baffle in roof opening prevents dust from settling into equipment.

t. Power Requirements:

CW Plate on, key closed	1000 w
Plate on, key open	
Filaments on	160 w
AM Plate on, 100% mod., 1000 cps	1350 w
Plate on, no modulation	
Filaments on	220 w

u. Number of Channels and How Selected: Two rf channels, either of which may be selected instantly by a channel selector switch. Two crystals, two sets of rf tank circuits and two antenna change-over relays are incorporated. Relays select the crystal, tank circuits and antenna circuit for the desired operating frequency. Presetting of the two channels anywhere in the specified frequency range is readily done by plugging in proper crystals, rf tank coils and PA plate chokes. Tank circuits have tuning controls on the front panel which are provided with a locking device.

v. Oscillator: The carrier is generated by multiplying the crystal oscillator frequency as follows:

<u>Carrier Frequency</u>	<u>Crystal Osc. Frequency</u>	<u>Multiplication</u>
2 - 4 mc	2 - 4 mc	x 1
4 - 6 mc	2 - 3 mc	x 2
6 - 14 mc	1.5 - 3.5 mc	x 4
14 - 30 mc	2.33 - 5 mc	x 6

w. Crystal Oscillator: Metal-plated crystals, AT cut, HC-6/U holder, non-temperature controlled. Two crystal sockets are provided, one for each channel.

x. Frequency Stability: Overall frequency accuracy is within .004%.

TABLE 1-4 (Cont.)

y. Crystal Calibration Accuracy: Crystals can be adjusted to exact frequency in the transmitter.

z. Temperature coefficient: With $\pm 0.0035\%$ total over the range 0 to $+65^{\circ}\text{C}$ or $\pm 0.0002\%$ over any 10° increment. The maximum ambient temperature to which the crystal is subjected in this transmitter exceeds the ambient temperature outside the cabinet.

aa. Harmonic and Spurious Radiation: Harmonic and spurious radiation at the output terminals is at least 30 db below carrier level.

ab. Method of Keying: A keying relay with wave-shaping filter keys the d-c power to the crystal oscillator plate and the multiplier screen. The crystal oscillates continuously using the control grid - screen grid section.

ac. Keying Speed: The transmitter is capable of OFF-ON keying at any speed up to 32 dot cycles per second (80 wpm). No wide band key clicks or chirp of the signal is present. No spikes or rapid transition of the keyed wave is present on oscilloscope presentation of the rf envelope. Distortion of pulse width, as indicated by the average power amplifier plate current does not exceed 20%.

ad. Transient Dip: Does not exceed 25%.

ae. Modulation Capability: 100% with sine wave or voice.

af. Modulation Method: High level plate modulation.

ag. Output Impedance: The transmitter employs two pi networks, each with two continuously variable capacitors and one plug-in inductor adjustable in 1-turn steps for matching any unbalanced load with a resistive component of 70 to 2000 ohms, provided the total load impedance does not require a higher voltage than does the 2000 ohms pure resistance. On frequencies above 4 mc, the lower resistance limit may be reduced to 50 ohms. A series load coil (plug-in accessory) will permit matching 50 ohms from 2 to 4 mc.

ah. Detailed Duty Cycle: The transmitter is designed for intermittent duty with "carrier on" time not to exceed 15 minutes in any 30-minute period at maximum ambient temperature. It is capable of continuous duty with accessory cooling Fan Kit; refer to table 1-3.

ai. Audio Input Impedance: Unbalanced, high impedance, for use with crystal or high impedance dynamic microphones.

aj. Audio Input Level: .005 volts is sufficient for 100% modulation at 1000 cps, without clipper.

ak. Microphone Facilities: One microphone input with push-to-talk connections.

am. Audio Frequency Response: Within 3 db from 150 to 3000 cps, without clipper. 25 db or more down at 4000 cps. Reference is 90% modulation at 1000 cps.

TABLE 1-4 (Cont.)

an. Audio Frequency Distortion: Less than 10% at 1000 cps with 100% modulation, without clipper.

ao. Noise Level: 40 db or more below 100% modulation at 1000 cps, without clipper.

ap. Audio Peak Clipper: A shunt type speech clipper using a double diode tube is followed by a low pass filter which cuts off sharply at 4000 cps. Both positive and negative peaks are clipped. The maximum modulation level is set by the clipping threshold control. The amount of clipping is controlled by the Audio Gain control.

aq. Carrier Shift: Does not exceed 5%.

ar. Front Panel Controls:

- Filament ON-OFF Switch
- Plate ON-OFF Switch
- Phone-CW Switch
- Audio Gain Control
- Filament Voltage Adjustment
- Low Voltage-Tune-Operate Switch
- Test Key Switch
- Channel Selector Switch
- Local-Remote Switch
- *2 Oscillator Plate Tuning
- *2 Multiplier Plate Tuning
- *2 Power Amplifier Plate Tuning
- *2 Antenna Loading

*Provided with locking device.

as. Other Controls: These controls which require infrequent adjustments are readily accessible inside the cabinet.

- *Audio Peak Clipper Threshold (screwdriver)
- Modulator Bias Adjustment
- Taps in Power Amplifier Output Network Inductor
- 2 Crystal Frequency Adjustment (screwdriver)
- 2 Multiplier Neutralizing (screwdriver)

*Provided with locking device.

at. Control Circuits: Control circuits are arranged and terminated for local control or remote control, using 2-1/2 pairs plus ground return from a Collins 177L-2 Remote Control Unit. Provision is made for mounting a Collins 175V-2 Relay Unit in the base of the transmitter cabinet for operation with the 177L-2 Remote Control Unit. Maximum allowable line loss is 25 db. Maximum allowable resistance of one wire plus ground return is 125 ohms. (Represents 3 miles of 19 ga telephone cable or 15 miles of 12 ga open wire.) See paragraph 1.1.3. (b).

TABLE 1-4 (Cont.)

au. Remote Control Functions: From a remote control position, these transmitter functions are controlled:

- Start (Filaments ON)
- Stop (Filaments OFF)
- Standby
- Channel Selection
- Emission Selection
- Keying
- Push-To-Talk (Carrier ON-OFF)
- Audio Gain
- Microphone Input Selection - The 177L-2 Remote Control Unit provides choice of two microphone input circuits, one for crystal or high impedance dynamic microphones, one for carbon button microphones.

av. Equipment Protection: Main primary power fuses are provided which protect the high voltage plate supply also. All other ac primary circuits are protected with fuses. Failure of the bias supply removes all plate voltage, thus preventing damage to tubes. A "tune-operate" switch limits the plate power input to the PA tube to a safe value during the tuning process.

aw. Personnel Protection: The main primary power switch is mounted on the front panel, and when placed in the "OFF" position, removes power from all circuits except the incoming power lines, and precludes starting or otherwise energizing the equipment.

ax. Ground Potential: All external parts except parts carrying energy to be radiated are at ground potential.

ay. Interlocks: Interlocks on the cabinet door remove primary power from all power supplies delivering more than 400 volts and shorts the HV supply output to ground when the door is open. (Only the 48 volt bias supply remains energized).

az. Indicating Devices:

- Multiplier Grid Current Meter
- PA Grid Current Meter
- PA Plate Current Meter
- Modulator Plate Current Meter
- PA and Modulator Filament Voltage Meter
- Two Antenna Current Meters
- Filaments ON Pilot Light
- Plate ON Pilot Light

ba. Vacuum Tube Classification: Commercial type tubes are used in the 30K-5 Transmitter.

TABLE 1-4 (Cont.)

<u>Type</u>	<u>Quan.</u>	<u>Function</u>	<u>Part Number</u>
6AG7	1	Crystal Oscillator	254 0518 00
807	1	Frequency Multiplier	256 0033 00
4-125A	1	R-f Power Amplifier	256 0068 00
6SJ7	1	Audio Amplifier	255 0030 00
6SN7	1	Audio Amplifier	255 0033 00
6H6	1	Clipper	255 0117 00
6B4C	1	Modulator Driver	255 0124 00
75TH	2	Modulators	256 0071 00
5R4GY	1	Bias Rectifier	257 0020 00
5R4GY	1	LV Rectifier	257 0020 00
866A	2	HV Rectifier	256 0049 00

bb. Controls for Auxiliary Equipment:

(1) Antenna Change-over: Relays change the transmitting antenna from the transmitter output to the receiver input automatically on standby. Two receiver input circuits are provided. Receiver input circuits are grounded when transmitting in either channel. Both transmitter output circuits are grounded in standby condition. Relays may be connected in a number of ways. Some possible combinations of this transmitter and two receivers for transmitting and receiving on two channels using the same antenna (s) are given below:

<u>Number of Antenna(s)</u>	<u>Number of Receivers Operating on Standby</u>
2	*Both, on separate antennas.
1	One at a time. Antenna disconnected from other receiver.
1	Both, on same antenna.

*As normally connected at the factory.

(2) Provision for Muting Receivers: Terminals are provided for operating a 115 volt, 50/60 cps relay for muting receivers. This circuit is energized when the high voltage plate supply primary is energized. One antenna transfer relay provides auxiliary spdt contacts.

1.3. CUSTOM MODIFICATIONS

1.3.1. Continuous Duty: Obtained by installing Fan Kit, Part No. 505 5037 002, in roof opening for additional cooling. Mounting holes are provided.

1.3.2. Operation from 50 cps Supply: For proper regulation of the HV supply, replace C-501, 0.1 MF 5000 volt capacitor Part No. 930 0042 00, with 0.15 MF 5000 volt capacitor, Part No. 930 0035 00. Mounting provisions are interchangeable.

1.3.3. Matching 50-ohm Loads Below 4 Mc: Each output network is provided with a jack bar (normally jumpered) for plugging in a series load coil to extend the lower resistance limit to 50 ohm from 2 to 4 mc.

1.3.4. Antenna Transfer to Receivers: Antenna transfer relays may be connected in a number of ways. Refer to bb. (1) of table 1-4. The output network is provided with one dpdt relay, Part No. 407 1006 00, to transfer the antenna to the desired channel. This relay has spdt auxiliary contacts. The output network is also provided with two additional dpdt relays, Part No. 407 1000 00, for transferring antennas to receivers and selecting either of two antennas.

1.3.5. Remote Control: Choice of local or remote control obtained by adding a 175V-2 Relay Unit, Part No. 520 4574 00, and a 177L-2, Part No. 520 4575 00, Remote Control Unit. Refer to au. of table 1-4.

TABLE 1-5
CHART FOR SELECTING CRYSTALS, RF INDUCTORS AND RF CHOKES

Carrier Freq. (Mcs.)	Total Freq. Mult.	Y101 or Y102 Crystal Freq.	Oscillator Plate		Multiplier Plate		PA Plate		RF Choke	
			L203 or L204 Freq. Range	Part No.	L207 or L208 Freq. Range	Part No.	L212 or L213 Freq. Range	Part No.	L210 or L211 Freq. Range	Part No.
2-2.6	1	2-2.6	2-2.6	503 3838 003	2.0-2.6	503 3828 003	2-4.5	520 4271 00	2-10	503 3821 002
2.6-3.4	1	2.6-3.4	2.6-3.4	503 3829 003	2.6-3.4	503 3829 003		520 4271 00		503 3821 002
3.4-4.0	1	3.4-4.0	3.4-4.5	503 3830 003	3.4-4.5	503 3830 003		520 4271 00		503 3821 002
4.0-4.5	2	2.0-2.25	2.0-2.6	503 3828 003	3.4-4.5	503 3830 003		520 4271 00		503 3821 002
4.5-5.2	2	2.25-2.6	2.0-2.6	503 3828 003	4.5-6.0	506 3624 003		520 4271 00		503 3821 002
5.2-6.0	2	2.6-3.0	2.6-3.4	503 3829 003	4.5-6.0	506 3624 003	4.5-8	503 3839 003		503 3821 002
6.0-6.8	4	1.5-1.7	2.6-3.4	503 3829 003	6.0-8.0	506 3625 003		503 3839 003	6-18	503 3822 002
6.8-8.0	4	1.7-2.0	3.4-4.5	503 3830 003	6.0-8.0	506 3625 003		503 3839 003		503 3822 002
8.0-9.0	4	2.0-2.5	3.4-4.5	503 3830 003	8.0-10.5	503 3833 003	8-14	503 3840 003		503 3822 002
9.0-10.5	4	2.25-2.625	4.5-6.0	506 3624 003	8.0-10.5	503 3833 003		503 3840 003		503 3822 002
10.5-12	4	2.625-3.0	4.5-6.0	506 3624 003	10.5-14	503 3834 003		503 3840 003		503 3822 002
12-14	4	3.0-3.5	6.0-8.0	506 3625 003	10.5-14	503 3834 003		503 3840 003	10-30	503 3823 002
14-18	6	2.33-3.0	4.5-6.0	506 3624 003	14-18	503 3835 003	14-24	503 3841 003		503 3823 002
18-24	6	3.0-4.0	6.0-8.0	506 3625 003	18-24	503 3836 003		503 3841 003		503 3823 002
24-30	6	4.0-5.0	8.0-10.5	503 3833 003	24-30	503 3837 003	24-30	503 3842 003		503 3823 002

SECTION 2 INSTALLATION

2.1. INSTALLATION.

2.1.2. PRELIMINARY.

(a) UNPACKING - Refer to the table of equipment supplied, table 1-1, of this instruction book and to the packing slip for a list of all units supplied. If the crates are marked with arrows to indicate the upright position, remove crate cover only. Use a nail puller to remove nails; a bar or hammer may damage the equipment within. Remove all of the packing material and lift each unit out carefully. Search all of the packing material for small packages. Inspect each unit for loose screws or bolts. Be certain all controls such as knobs, switches, etc., work properly. All claims for damage should be filed promptly with the transportation company. It is necessary to preserve the original packing box and the packing if claim is to be made.

2.1.3. INSTALLATION PROCEDURE.

(a) PLACING THE CABINET - The transmitter cabinet may now be set in place. It may be located for convenience of operation, but at the same time consideration should be given to power connections, control cables (if required) antenna and ground connections and maintenance accessibility. The required clearances and base dimensions are shown in figure 2-1. Because all units are placed in the cabinet from the rear, clearance should be allowed for a workman between the cabinet and any obstruction. In addition, sufficient clearance should be provided to allow for the rear door to swing back fully out of the way.

(b) INSTALLATION OF UNITS - Reference to the photographic illustrations will assist in the assembly of the transmitter. See figure 2-3. Any cords designed to hold the cable in place for shipment should be untied and removed. Place the heavy plate power transformer in position at the bottom of the cabinet and make the connections indicated by the white tags tied to the cable lugs. After this, the power transformer may be placed over the mounting holes and bolted into place if desired. Proceed with the placement of units from the bottom to the top. The tabulation below lists the various units of the transmitter. For purposes of identification the unit letter designation which appears on the cabling schematic diagram, figure 5-16 is also shown.

<u>Unit Letter Designation</u>	<u>Description</u>
A	Meter Panel
B	R-F Exciter, Amplifier and Antenna Network
C	Speech Amplifier and Modulator
D	Low Voltage and Bias Power Supply
E	Control Panel
F	High Voltage Rectifier

<u>Unit Letter Designation</u>	<u>Description</u>
G	High Voltage Power Transformer
H	Type 175V-2 Relay Control Unit
J	Relay Voltage Supply and External Connection Strip

Each unit should be placed with protruding control shafts properly centered to prevent binding and then bolted in place with bolts provided for that purpose. A set of Bristo wrenches is attached to the rear door to be used for tightening the control knob setscrews.

(c) INTERNAL CONNECTIONS - The connections between the units of the type 30K-5 Transmitter are made by a pre-formed cable. The cable leads are formed and laced tightly so that they have a natural tendency to seek the proper terminal. Each wire is color coded and otherwise identified on the cabling schematic, figure 5-16, by means of the unit letter and terminal number to which each wire is terminated. Each cable connection in the transmitter is marked by a tag when the transmitter is dismantled for shipment. The cable connections can therefore be properly installed by following the markings on the tags.

The order of designation of interunit cabling is as follows: When a wire terminates on a single numbered terminal on a unit, the wire route is from the source to the terminal on the specified unit and is indicated by the unit letter designation followed by the terminal number. Thus, if a wire emanating from terminal number 2 on unit A is to be connected to terminal number 12 on unit C, an arrow at terminal number 2 on unit A would indicate C12 and a similar arrow on terminal 12 on unit C would indicate A2.

Color coding of wires is used to facilitate connecting cables to terminal strips. The code is indicated by a letter such as A, B, etc., followed by a figure such as 1, 3, 5 etc. The letter designates the wire structure size, amount and kind of insulation and rating. The figures refer to RMA color code for resistors, etc. A class A wire with solid red covering would be an A2 while a class A tracer wire with a red body and a white tracer would be designated A29.

(d) FUSES - All fuses should be examined and their ratings checked. Refer to the MAINTENANCE section of this book paragraph 5.2.2.(b) for a table of fuses.

(e) EXTERNAL CONNECTIONS - Place all POWER switches in the OFF position before attempting to make any external connections. The external connections for the type 30K-5 transmitter consists of the following: ac power line, microphone, radiation system, remote control lines if used.

(1) AC POWER LINE - The type 30K-5 is designed to operate from a 230-volt, single-phase, 60-cycle power source. The supply line voltage and frequency should be checked before connections are made. The maximum load used by this equipment is 1350 watts. A power line of at least 2 kva capacity should be installed for each transmitter installation. Connect the power line directly to the bottom terminals of the line fuse block in the bottom of the cabinet. Number 10 AWG or larger, suitably insulated wire should be used. It is recommended that an external, wall-mounting, two-pole, disconnect switch be installed between the transmitter

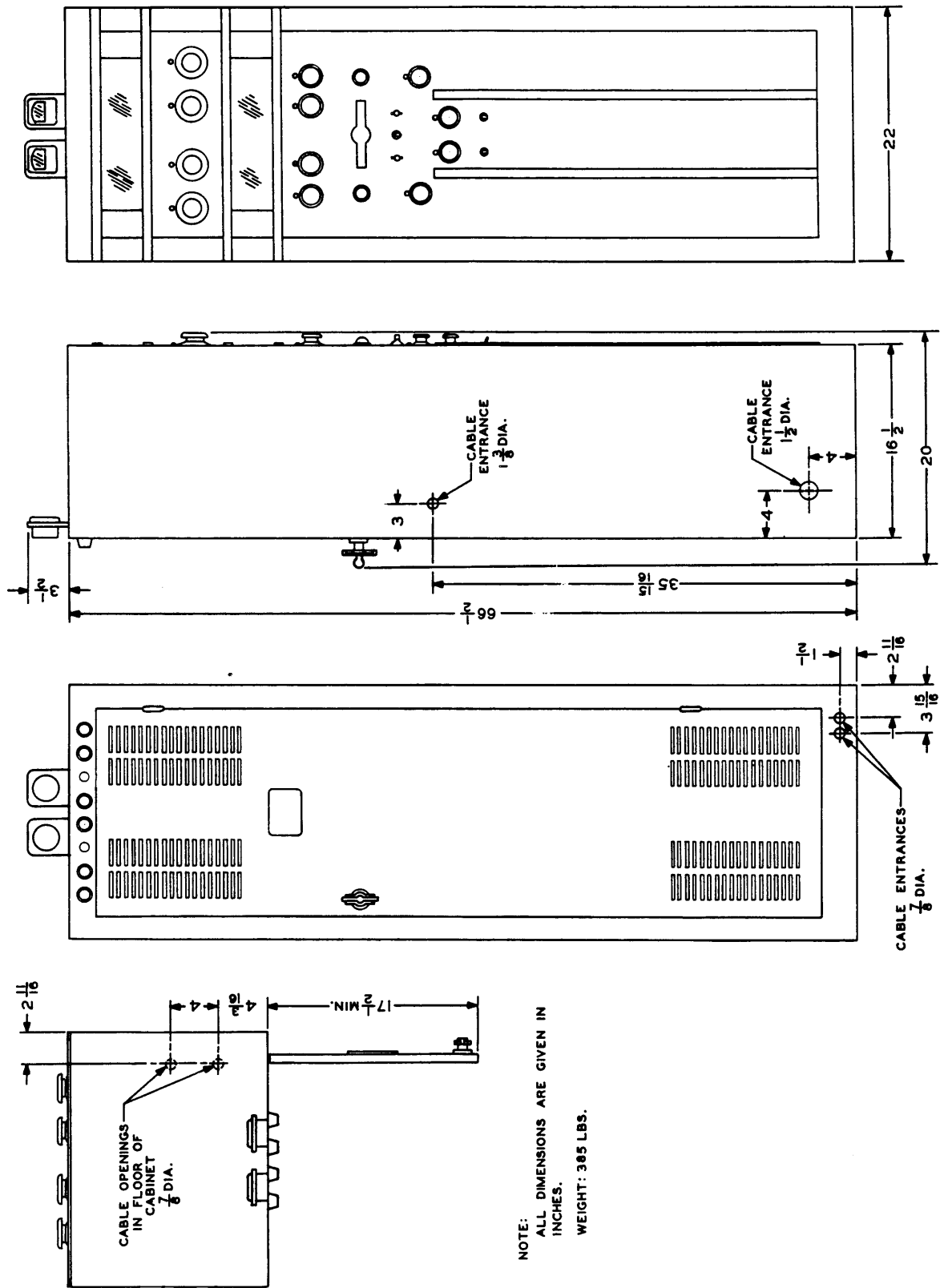
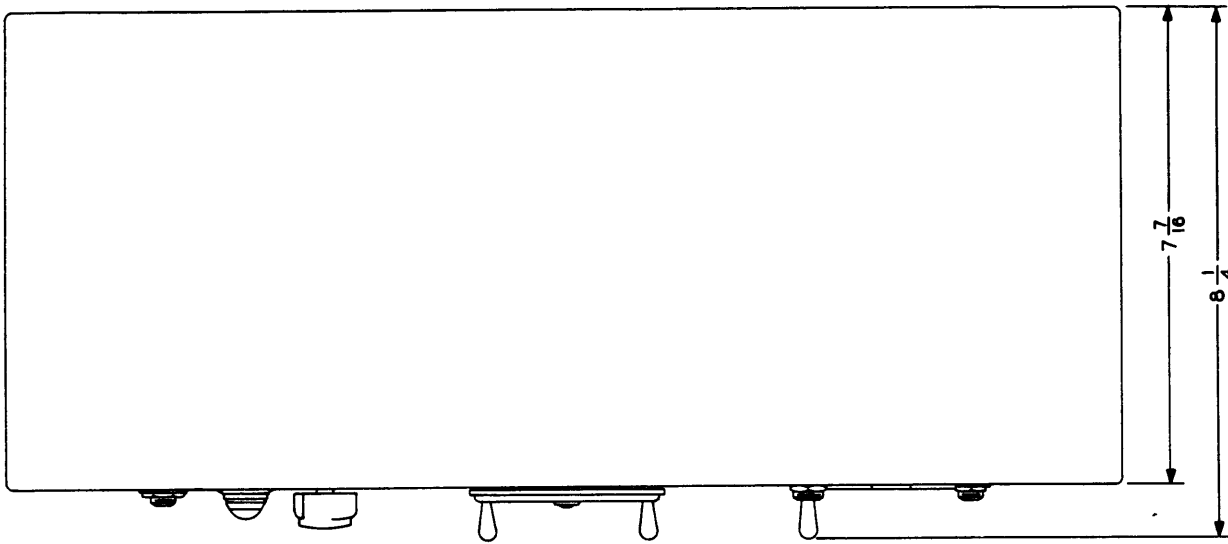

Figure 2-1. Type 30K-5 Transmitter Outline and Mounting Dimensions



NOTE:
ALL DIMENSIONS ARE IN INCHES.
WEIGHT:

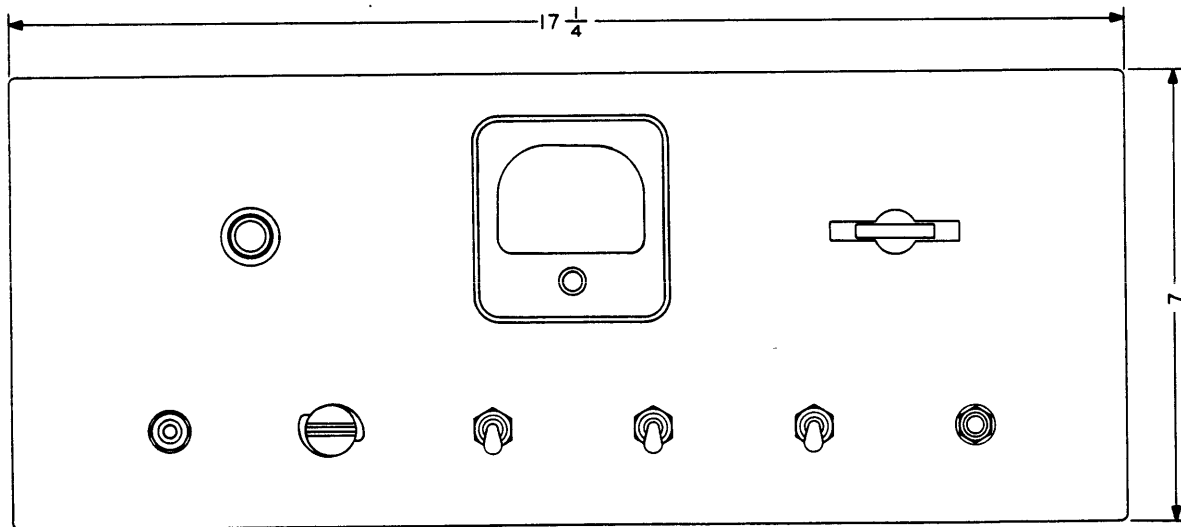

Figure 2-2. Type 177L-2 Remote Control Unit Outline and Mounting Dimensions.

and the main line connections. If the line voltage is more than 10 volts too low or too high, the installation of an auto transformer is advisable.

Two holes $7/8$ " in diameter are available in the base of the cabinet for power leads, if conduit type of wiring is used; otherwise, the power leads may enter the cabinet through holes in the base and thence through the above-mentioned holes to the terminal board. Refer to figure 3-1 for location of the power entry holes. A $1-1/2$ " hole in the side of the cabinet at base level is also available for power lead entry.

(2) MICROPHONE - The push-to-talk and microphone connections are made by means of Amphenol type MC 4M four-connector plug. The microphone receptacle is located at the rear of the modulator chassis and the microphone cable may enter the side of the cabinet; a $7/8$ " hole is provided. The ring on the microphone plug should be securely tightened. For LOCAL push-to-talk operation, remove the jumper from terminals 5 and 6 on unit C (speech amp and modulator), and place TEST KEY in the "locked" position.

(3) RADIATION SYSTEM - The output networks will match an extremely wide range of antenna impedances with excellent efficiency. At lower frequencies, and for antenna less than a quarter wave in length provision is made for load coils which will assist in matching the antenna impedance. Unbalanced antenna and single wire or concentric transmission lines can be matched directly. See figure 2-5 for suggested antennas and circuits. Refer to paragraph ag. of table 1-4 for a description of the usable output impedances.

The details of the radiation system for any transmitter can best be determined at the time the installation is being made. Certain factors which will affect the operation of the equipment, however, should be considered before the installation is completed. With the 30K-5 Transmitter a single antenna may be used for all frequencies provided space is available to install a suitable radiating system. When a single antenna is used for several operating frequencies, the antenna in general will not be resonant at all frequencies involved. For this type of operation it is recommended that a vertical radiation system be installed wherever possible. Such a vertical radiator would consist of either a self-supporting insulated tower or a guyed tower or mast supported on a base insulator. When several transmitters are being installed at the same location, it is sometimes desirable to erect two tall masts to which a messenger cable may be attached. By connecting large diameter conductors to the messenger cable supported by the masts, several vertical radiating systems each having different properties may thus be installed. This arrangement in general will result in a satisfactory radiating system for the 30K-5 Transmitter, if the conductor diameter is $3/4$ " to 2". When limitations are placed on the height to which the radiating system may extend, a single end fed antenna of at least $3/8$ inch outside diameter may be used.

In any case serious attention should be given to the installation of a suitable ground system. In the case of a vertical radiator, use 60 radials of 8 to 10 gauge bare copper wire spaced 6 degrees apart and terminated at a common heavy conductor as near the base of the radiator as possible. The length of these radials

should be at least a quarter wavelength referred to the lowest operating frequency. The connections from this ground mat to the transmitter ground terminal at the roof of the r-f bay should be made by means of a heavy copper conductor or copper bus. See figure 2-6.

For a single wire end fed horizontal antenna, the ground system should have the following configuration. A system of radial wires of 8 to 10 gauge bare copper, spaced six degrees apart covering approximately 225 degrees and extending for approximately a quarter wavelength (referred to the lowest operating frequency), should be installed with their center directly below the vertical or feed line portion of the antenna. The area covered by the radials should be the portion opposite the open end of the horizontal part of the antenna. Attached to and emanating from the common junction or center of the radial system should be a group of wires spaced 5 or 6 feet apart and laid parallel with the horizontal portion of the antenna and extending for at least an eighth wavelength (referred to the lowest operating frequency) beyond the open end of the antenna and approximately an eighth wavelength on each side of the horizontal portion of the antenna.

The use of a suitable ground system such as outlined above will improve the radiating efficiency of the installation and will reduce excessive radio frequency voltages appearing in the control circuits, particularly the telephone line control equipment.

The height of the vertical radiator should be determined for the lowest frequency and should be at least one-quarter wavelength at this frequency.

For an end fed horizontal antenna, the ratio of the length of the vertical portion to the horizontal portion should be as large as possible. Whenever possible the height of the antenna should be at least one-quarter wavelength at the lowest frequency. The total length of the antenna including the vertical portion or lead-in should be adjusted to avoid the immediate vicinity of a half wavelength at any of the operating frequencies. Whenever this condition exists, regardless of the choice of total length, the end fed antenna should not be used.

At the building entrance for each antenna, a horn gap should be installed to reduce the danger of damage to the equipment due to electrical storms or disturbances. Refer to figure 2-7 for recommended installation details.

Connect the antenna to the terminals at the top rear of the transmitter. Connect the ground system to the terminal on the cabinet base. See figure 2-4.

Refer to section VII for additional antenna information.

(4) REMOTE CONTROL UNIT CONNECTIONS - A 7/8" diameter hole is provided at the cabinet base for entrance of remote control lines if used. Refer to figure 2-4.

In remote control operation using the 177L-2 Remote Control Unit, the distance from which the transmitter may be controlled is determined by the line loss. The loss in the line cannot exceed 25 db nor should the resistance of any wire plus ground return exceed 125 ohms. This represents 2.8 miles for #19 GA telephone cable, 1.4 miles for #22 GA and 0.56 mile for #26 GA. This distance from the transmitter can be extended considerably by using #12 open wire line which can be used up to 15 miles. For the longer distances using the smaller wire, the voltage

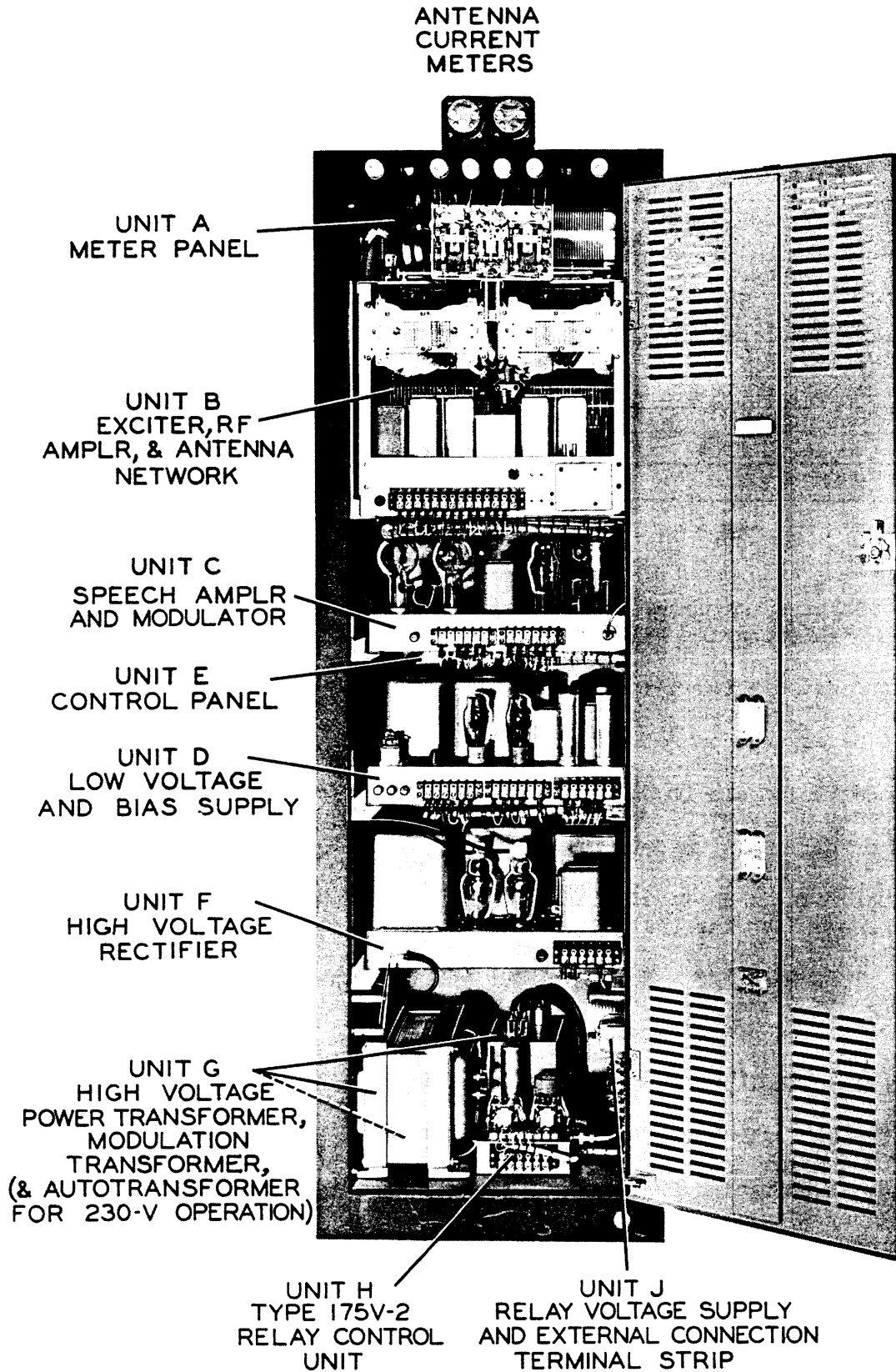

Figure 2-3. Unit Placement Photograph

adjustment tap on the relay supply transformer, T102, should be set on tap number 6. Also, low operating current telephone type relays can be installed in the 175V unit to operate the heavier relays therein.

The 177L Remote Control Unit is connected to the 30K-5 Transmitter as shown in the following table:

177L-2 Terminal No.		175V-2 Terminal No.	30K-5 Terminal No. (On Sidewall of Cabinet)
7	Connect to	7	
8	Connect to	6	
9	Connect to		3
10	Connect to		4
11	(to earth GND)		15 (to earth GND)
12	Connect to		10

NOTE

Be sure to remove the jumpers between J5 and 6 and J7 and 8 when using the 175V-2 Relay Unit.

Audio connection between the 175V-2 Relay Unit and the modulator unit is made by a short piece of microphone cable provided for this purpose. This cable is supplied with necessary connectors. Connection is made between J701 and J301.

Notice that terminals 10 and 11 on the 175V-2 Relay Unit connect to N.O. contacts on plate relay K702. These contacts may be used for operating auxiliary apparatus or for muting receivers.

If cw operation is employed when using the 177L-2 Remote Control Unit, jumper terminals 1 and 2 on the rear of the 177L-2 or lock the push-to-talk switch closed.

(5) TELEGRAPH KEY - For local keying, plug the key into jack J101 in the base of the 30K-5 and place the LOCAL-REMOTE switch in the LOCAL position and the TEST Switch in the NORMAL position.

For remote keying, plug the key into the key jack on the front of the 177L-2 unit.

(f) CRYSTALS AND INDUCTORS - The transmitter is shipped with crystals and inductors for the two frequency channels specified at the time of purchase. However if a change in operating frequency is contemplated the proper tank circuit inductors may be selected from table 1-5.

NOTE

Before operation of the transmitter is attempted, be sure the flexible plate lead to the 4-125A PA tube does not touch the glass envelope of the tube.

If cw operation is used from the 177L-2 Remote Control Unit, terminals 1 and 2 on the rear of the unit should be jumpered, or in lieu of this, the microphone push-to-talk switch can be locked in the ON position.

(g) ANTENNA CHANGE-OVER - The 30K-5 Transmitter is equipped with a pair of relays for automatically changing the transmitting antenna from the transmitter output to a receiver input so that the efficiency of the transmitting antenna may be utilized in receiving. These relays, K207 and K208, one for each channel, are a-c operated and are connected to be energized when the carrier is on. Thus energized, the receiver input is grounded and the transmitter output is connected through to the antenna. When the relays are unenergized, the antenna is connected through to the receiver input and the transmitter output circuit is grounded.

The relays may be connected in a number of ways. As shipped from the factory, the transmitter is connected for use with two separate antennas and with facilities for two receivers. In this case, the network switching contacts on K205 are not used and the output terminal of each network is connected through its respective antenna change-over relay to an antenna terminal. The inputs of both receivers will be grounded when transmitting on either channel and likewise, the outputs of each network will be connected to its respective antenna during transmission on either channel. During reception, each receiver input will be connected to its individual antenna.

The transmitter may be connected to supply one of two receivers at a time from one antenna by connecting as indicated in figure 2-8B. In this arrangement, the network output selector contacts on relay K205 are used to shift the antenna from one network to the other when changing channels. One receiver will be connected to the antenna during receiving while the other receiver will be disconnected from the antenna. It is possible to connect the relays together in such a fashion that both receivers are supplied from the same antenna at the same time, at a sacrifice in efficiency, however, by placing a jumper as indicated by the dotted line in figure 2-8B.

If desired, a muting relay with a 115 volt a-c coil can be connected to terminals 11 and 12 in the base of the transmitter cabinet (unit J) to mute the receivers during transmitting periods to prevent undesirable noises being produced by the receivers which sometimes happens when the transmitter and receiver are in close proximity to each other.

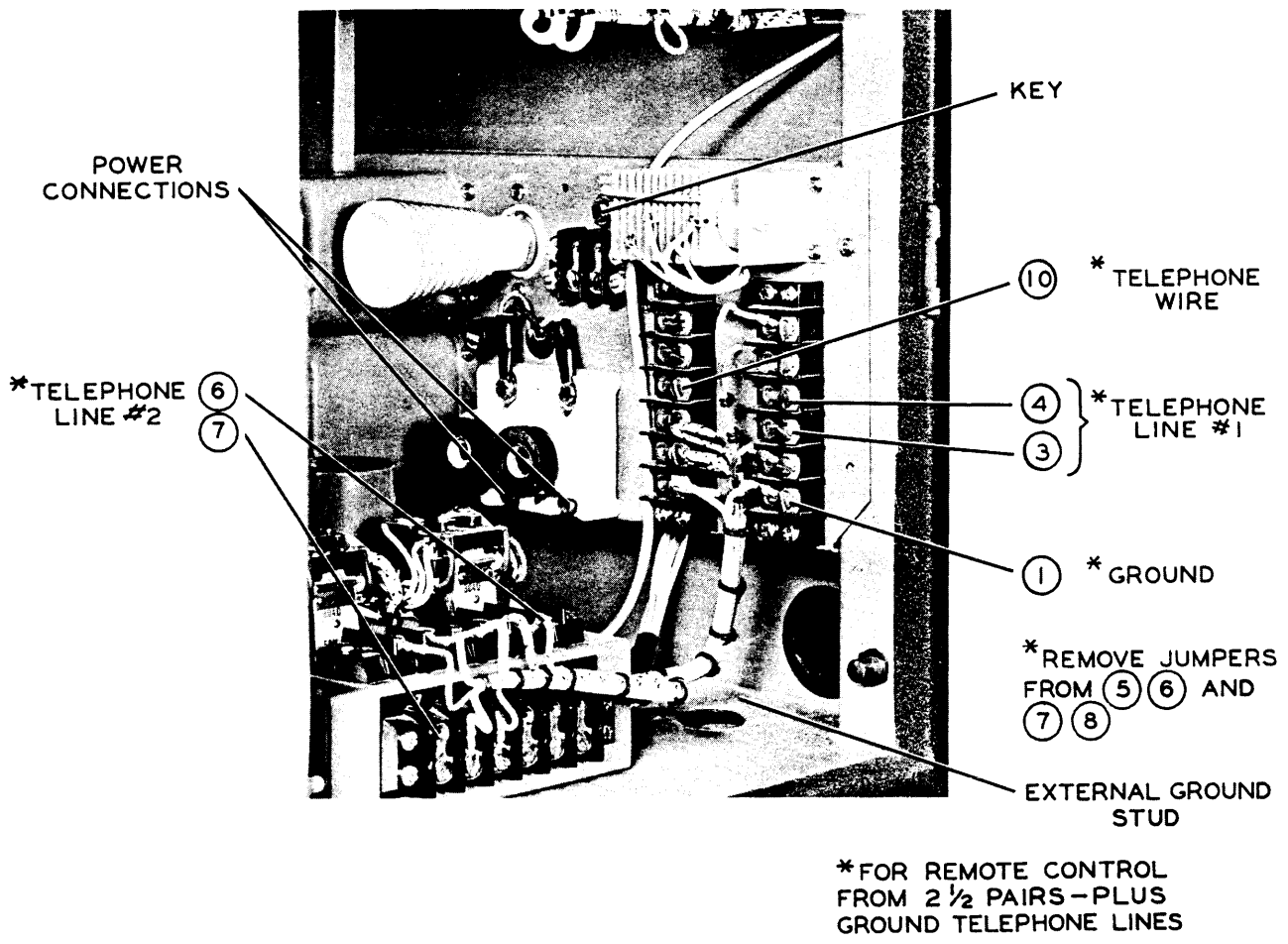

Figure 2-4. External Connections

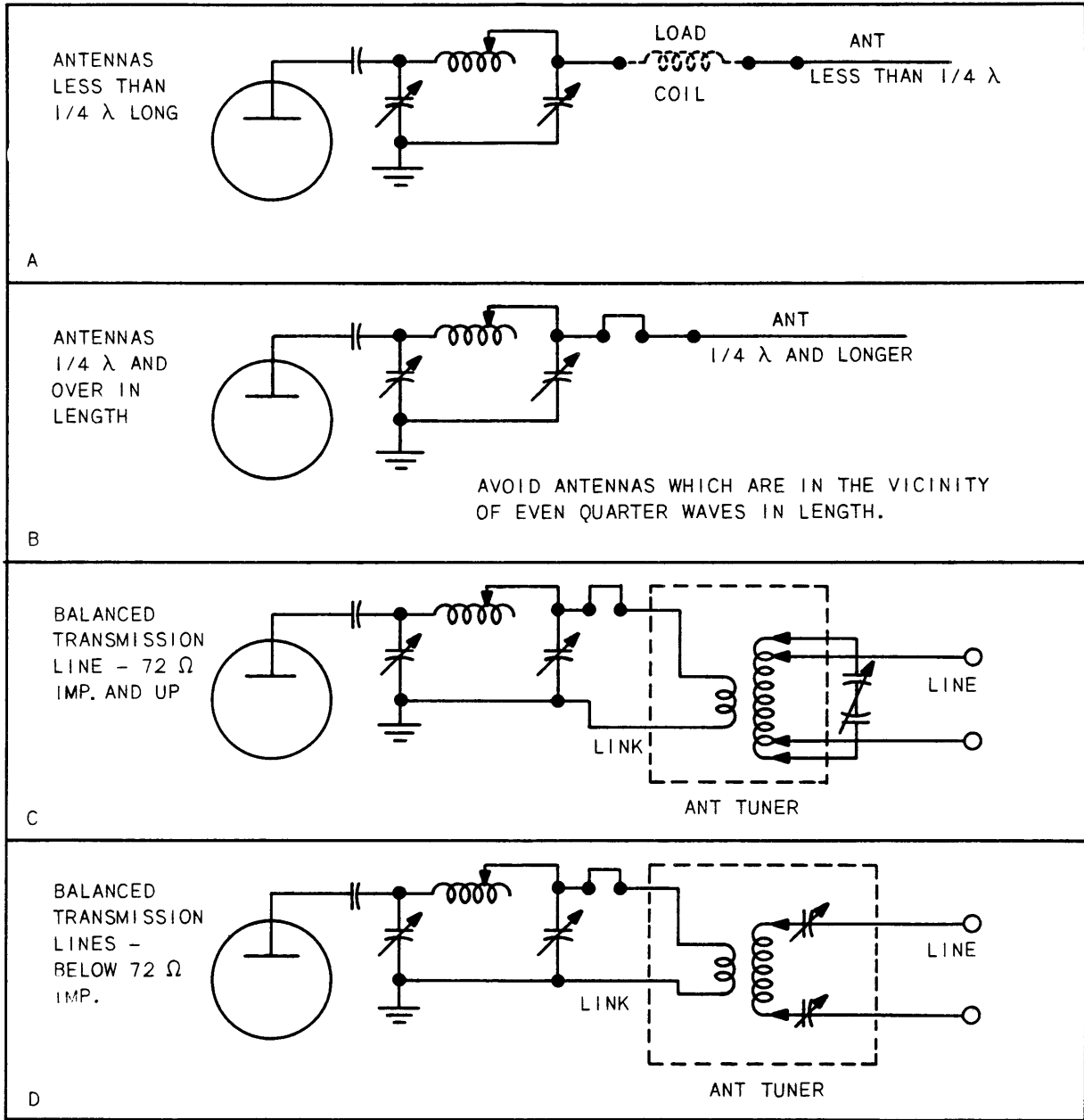

Figure 2-5. Applicable Antenna Circuits

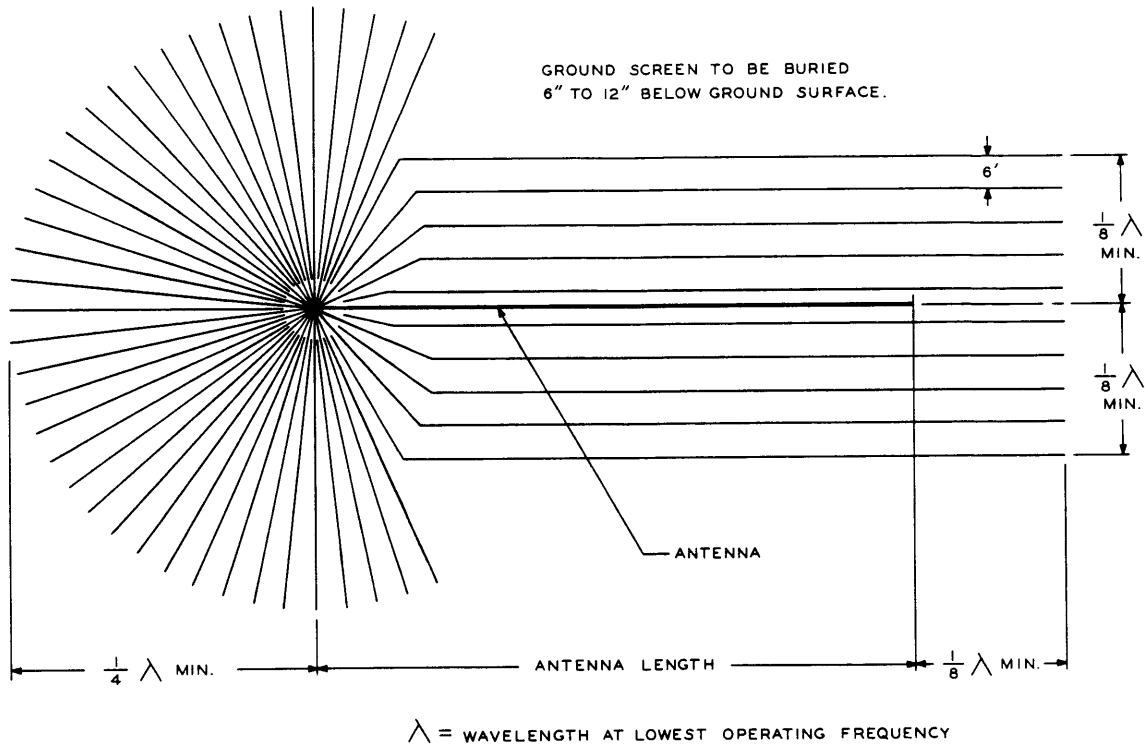

Figure 2-6. Suggested Ground System

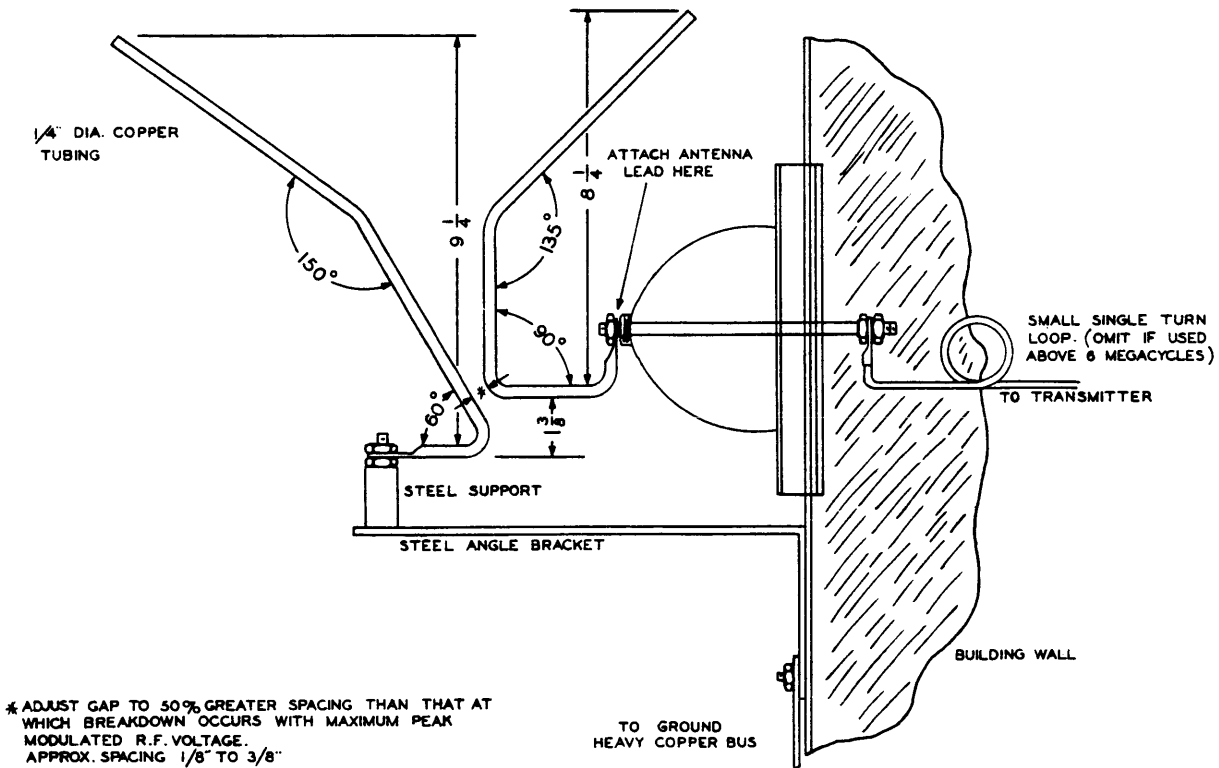

Figure 2-7. Antenna Horn Gap

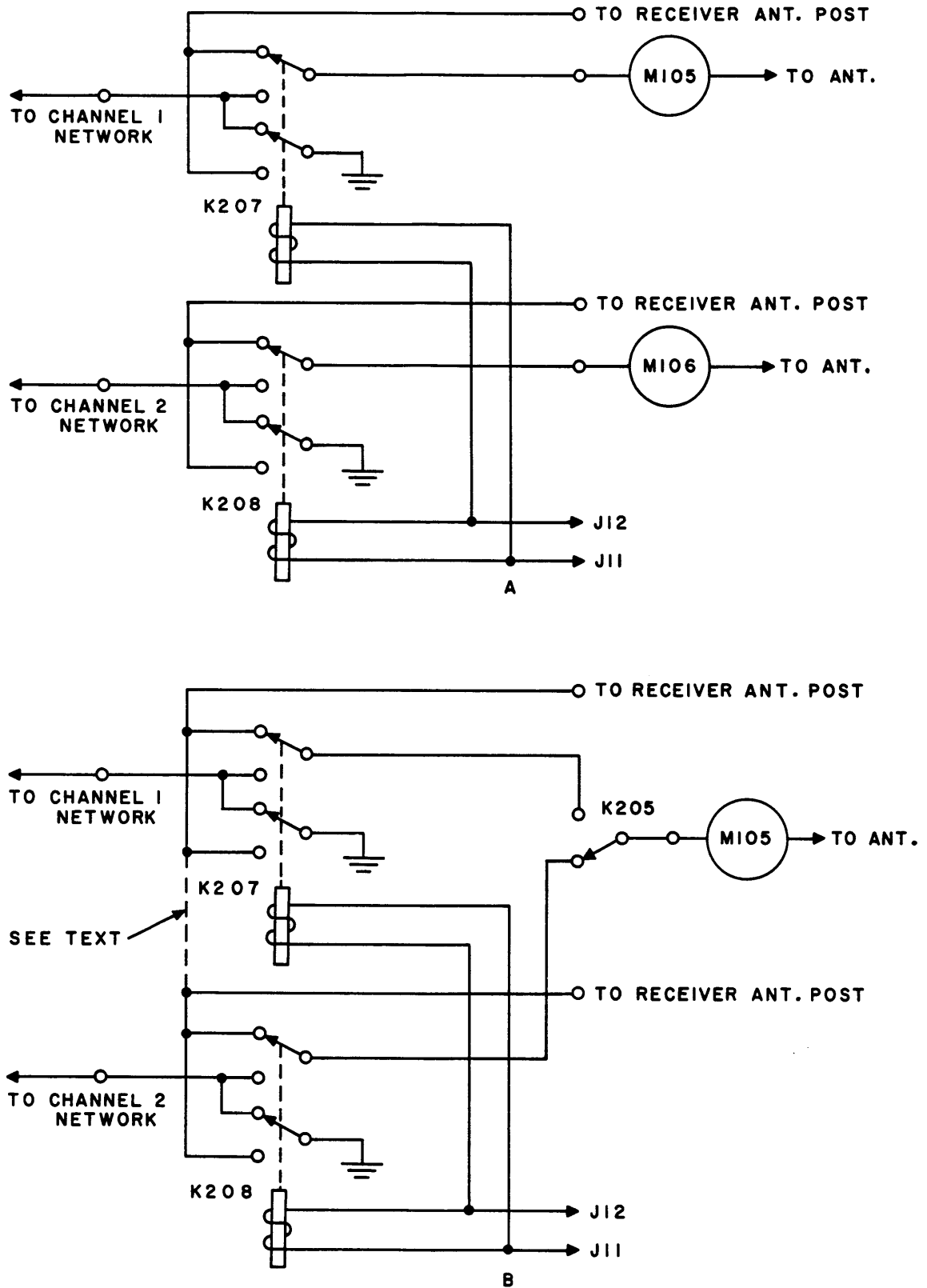
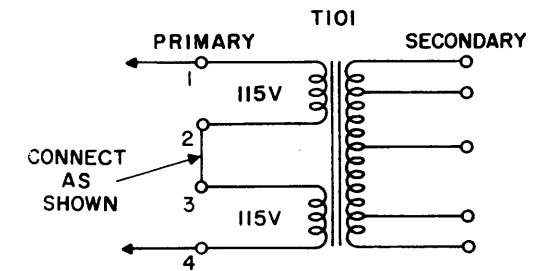
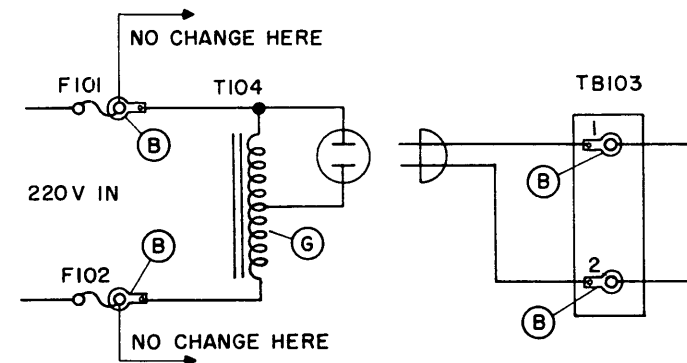
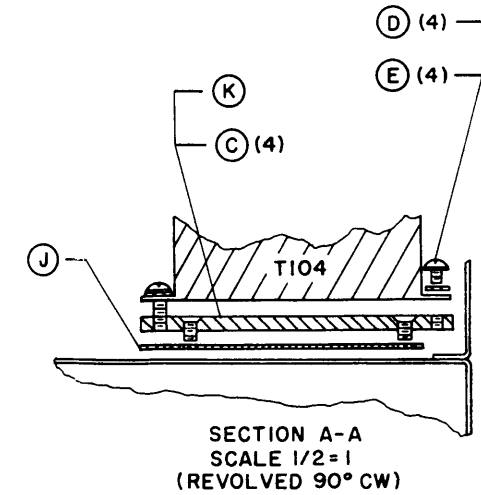
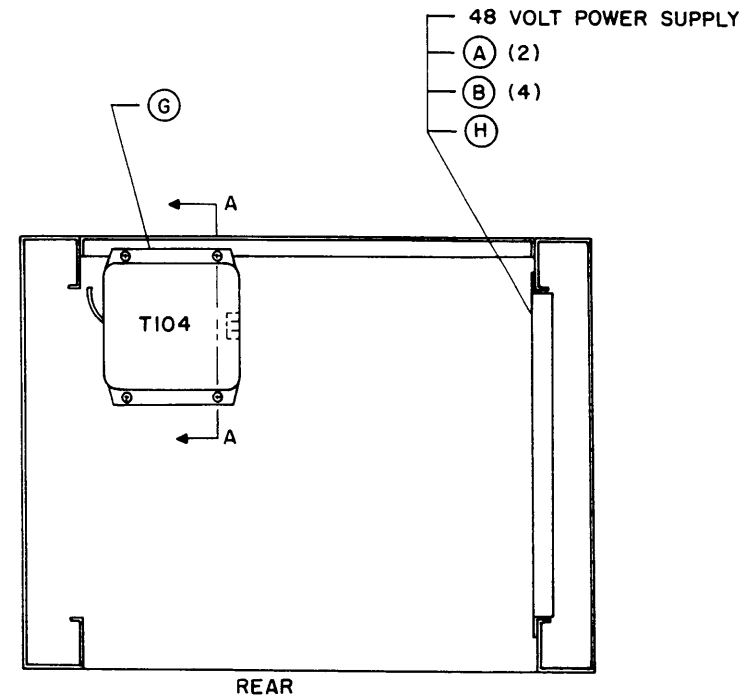

Figure 2-8. Antenna Change-Over Relay Circuits

INSTALLATION



NOTES:

1. MOUNT AUTOTRANSFORMER T104 (G) AS SHOWN.
2. REMOVE THE 2 JUMPERS BETWEEN TB103 AND F101, F102, SEE COMPLETE SCHEMATIC.
3. ROUTE THE AC INPUT CORD FROM T104 ALONG THE FRONT OF THE CABINET BRINGING IT OUT THROUGH THE GROMMET ABOVE F101 AND F102. CUT OFF, ADD 2 LUGS (B) AND CONNECT TO F101 AND F102. POLARITY UNIMPORTANT.
4. INSERT THE MALE PLUG, OF THE AC CORD THAT WAS CUT OFF, IN THE FEMALE RECEPTACLE OF THE AUTOTRANSFORMER AND ROUTE ALONG WITH THE PREVIOUS CORD TO TB103. ADD 2 LUGS. (B)
5. CONNECT THE 2 AC CORDS AS SHOWN IN THE SCHEMATIC
6. RECONNECT THE PRIMARY OF T101 FOR 230 VOLT OPERATION BY CONNECTING THE TWO WINDINGS IN SERIES. MAKE CERTAIN THE WINDINGS ARE SERIES AIDING, NOT SERIES BUCKING.
7. REMOVE PRESENT 20 AMP FUSES F101 AND F102 AND REPLACE WITH 10 AMP. (A)
8. REMOVE PRESENT HR101 AND INSTALL 220 VOLT UNIT. (H)
9. CHECK ALL CHANGES BEFORE APPLYING POWER.
10. REMOVE NAMEPLATE AND INSTALL NEW NAMEPLATE.

NOTE: REVERSE PROCEDURE FOR 115V OPERATION.

QUAN- TITY	ITEM NO.	QUANTITIES ARE FOR ONE ASSEMBLY	
		COLLINS PART NO.	PART NAME
2	A	264 0171 00	FUSE - 10 AMP.
4	B	304 1800 00	TERMINAL - LUG, NO. 8
4	C	342 0224 00	SCREW - MACH, 10-32 X 1/2 FLT. HD
4	D	343 0225 00	SCREW - MACH, 10-32 X 5/16 PBH
4	E	373 8040 00	WASHER - NO. 10 LOCK
	F		
1	G	662 0165 00	AUTOTRANSFORMER
1	H	711 0093 00	RESISTOR
1	J	540 5963 002	PLATE - SHIM
1	K	540 5964 002	PLATE - XFMR MTG

Figure 2-9. 30K-5 Conversion to 220-Volt Operation

2.2. CONVERSION TO 115-V OPERATION.

A 230-volt transmitter may be converted to 115-volt operation by making a few simple reconnections and changing a few parts.

In 115-volt operation, the autotransformer T104 is no longer used and the primary fuses, F101 and F102, must be changed to 20 ampere capacity. The "tune" resistor, HR101, must be changed to a 115-volt size.

Use the following procedure to convert a 230-V transmitter to a 115-V transmitter:

- a. Disconnect all primary power from the transmitter.
- b. Remove the jumper between terminals 2 and 3 of power transformer T101.
- c. Connect terminal 1 to 3 and terminal 2 to 4 of power transformer T101.
- d. Disconnect the primary input cord of autotransformer T104 from fuses F101 and F102.
- e. Pull the plug from autotransformer T104.
- f. Tape up and tie all disconnected leads out of the way.
- g. Add the two jumpers from fuses F101 and F102 to the terminals of TB103 (see figure 5-16).
- h. Remove tune resistor HR101 and replace with a 115-V unit (Collins part number 711 0003 00).
- i. Remove the two primary fuses and replace with 20 ampere fuses (Collins part number 264 0168 00).
- j. Revise the name plate to indicate that the transmitter is now a 115-V transmitter.
- k. Connect transmitter primary power input to a source of 115-V, 50-60 cps, single phase.

2.3. CONVERSION TO FREQUENCY SHIFT KEYING.

Adapters are available for converting the crystal oscillator stage into a radio-frequency amplifier into which an external frequency shift exciter can be fed. The adapters come in pairs, one for each channel. These adapters are plugged into the crystal sockets in place of the crystals. Each adapter is equipped with a coaxial fitting into which the radio-frequency signal is fed. View the crystal sockets from the rear of the transmitter; the 542 0477 003 adapter plugs into the left-hand crystal socket and the 542 0476 003 adapter plugs into the right-hand socket.

The adapters contain a 56-ohm load for terminating the input coaxial line, therefore, use a type RG-58/U coaxial line. A plug for the line is furnished with each adapter.

Install the FSK adapters as follows:

a. Remove the two crystals.

b. Observe that each adapter has a protruding stud that is used to secure the adapter to the r-f unit chassis but that there is only one hole in the chassis available. Diagonally from this hole across the sockets is another hole that is at present being used to mount a bolt that secures a grounding lug underneath the chassis. Remove the bolt that secures the lug and use the stud that mounts the adapter to secure the grounding lug. Plug in the adapters and secure them to the r-f unit chassis.

c. There is a cable clamp furnished with each adapter. Install these to secure the coaxial cable to the chassis. Use the two screws that fasten the right-hand, rear, upright angle to the chassis.

d. Install the plugs on the ends of the cables, run the cables through the side of the transmitter cabinet, and attach the plugs to the adapters. Run the cables through the cable clamps, adjust the cables and tighten the cable clamps. The installation is now complete. Use no more grid drive to the oscillator tube than it takes to produce the normal amount of grid drive to the final amplifier under the normal crystal control conditions.

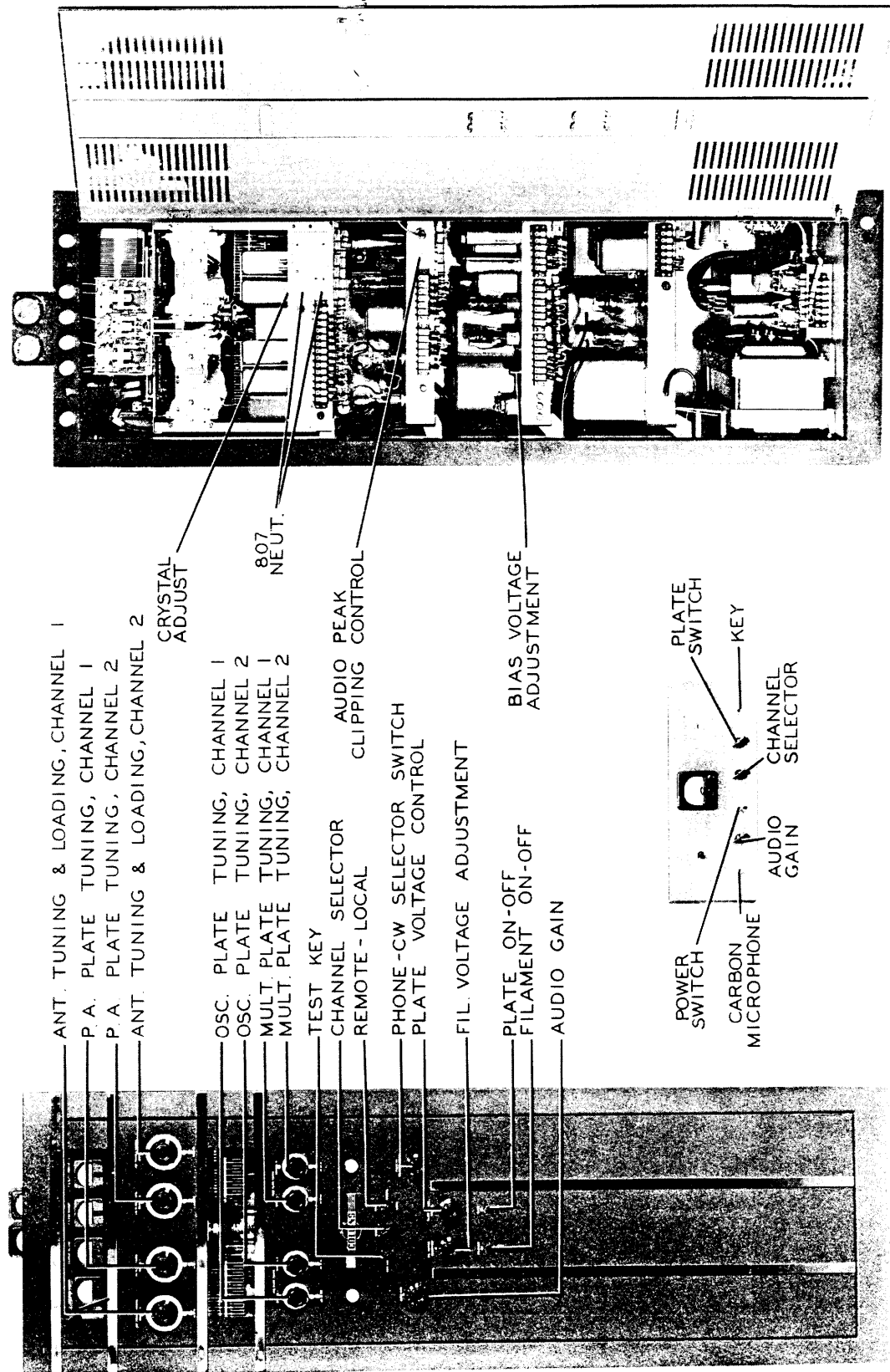

Figure 3-1. Control Functions

SECTION 3

ADJUSTMENT AND OPERATION

OPERATION OF THIS EQUIPMENT INVOLVES THE USE OF HIGH VOLTAGES WHICH ARE DANGEROUS TO LIFE. OPERATING PERSONNEL SHOULD AT ALL TIMES OBSERVE ALL SAFETY PRECAUTIONS. DO NOT CHANGE TUBES OR MAKE ADJUSTMENTS INSIDE EQUIPMENT WITH SUPPLY VOLTAGE ON. DO NOT DEPEND UPON DOOR INTERLOCK SWITCH FOR PROTECTION BUT ALWAYS OPEN THE MAIN SWITCH IN SUPPLY LINE TO EQUIPMENT.

3.1. GENERAL. - After the installation wiring is complete and the tubes, fuses, crystals and inductors have been properly positioned in their respective sockets, the equipment is ready for initial operational adjustment. All important operating controls are located on the front panel of the transmitter and each is clearly designated as to function. The following paragraphs list the control designations and circuit elements controlled by each. Refer to figure 3-1.

3.1.1. FILAMENT, ON-OFF switch. This switch, S105, energizes or de-energizes the primary windings of relay and bias transformers T102 and T401 and the following filament transformers: T201, T303 and T501.

3.1.2. PLATE, ON-OFF switch. This switch, S106, will apply power to the primary winding of low voltage plate transformer T402. If the plate voltage control is in the TUNE or OPERATE position, the primary winding of high voltage plate transformer T101 will be energized, also.

3.1.3. FIL VOLTAGE ADJUSTMENT. This switch, S104, selects taps on the primary winding of the power amplifier and modulator filament transformer; T303, thereby giving a small range in the voltage applied to the tube filament.

3.1.4. PLATE VOLTAGE CONTROL. This switch, S107, has three positions; LV, TUNE and OPERATE. When placed in the LV position no plate voltage is applied to the r-f amplifier or modulator tubes, allowing tuning adjustments to be made on the exciter section of the transmitter and grid of PA. In the TUNE position a resistor, R101, is connected in series with the primary of the high voltage plate transformer T101 resulting in a reduced voltage on the r-f amplifier and modulator tubes. When rotated to the OPERATE position full plate power is applied to these tubes.

3.1.5. PHONE-CW SELECTOR switch. When this switch S109 is placed in the CW position the filament supply voltage to the modulator tubes is removed and the secondary windings of the modulation transformer T302 is short-circuited. In the PHONE position the circuits are returned to normal operations.

3.1.6. TEST KEY. The test key, S101, serves to close the carrier control circuit during the time tuning adjustments are being made. If the switch is operated in one direction the key will immediately return to the normal position when released; if operated in the opposite direction the key will lock to permit the making of

tuning adjustments without the necessity of holding the telegraph key closed or the push-to-talk button on the microphone operated.

3.1.7. CHANNEL switch. Either one of the two predetermined frequency channels may be selected by operation of this switch, S102. In the CHANNEL 1 position relays K204 and K205 are energized and relays K202 and K203 are not energized. When S102 is in the CHANNEL 2 position relays K204 and K205 are not energized and relays K202 and K203 are energized.

3.1.8. LOCAL-REMOTE CONTROL switch. Operating this switch, S103, to the REMOTE position, allows the transmitter to be operated by remote control. A type 177L-2 Remote Control Unit is necessary if the distance from the operating position is greater than fifty feet.

3.1.9. OSC PLATE TUNING. The CHANNEL 1 control operates capacitor C206, while CHANNEL 2 control operates C207.

3.1.10. MULT PLATE TUNING. The CHANNEL 1 control operates C212 and the CHANNEL 2 control operates C213.

3.1.11. ANT TUNING and LOADING. The CHANNEL 1 control operates capacitor C218 and the CHANNEL 2 control operates capacitor C223.

3.1.12. PA PLATE TUNING. The CHANNEL 1 control operates capacitor C219 and the CHANNEL 2 control operates capacitor C222.

3.1.13. AUDIO GAIN. The AUDIO GAIN control operates the potentiometer R306. The control permits adjusting of the input to the audio amplifier tube V302. The speech amplifier gain increases as the control is rotated from 0 toward 10.

3.2. ENERGIZING THE EQUIPMENT FOR THE FIRST TIME.

3.2.1. PRECAUTIONS - Before applying any voltage to the transmitter a thorough inspection of all connections should be made for tightness and clearance to structural parts which are at ground potential.

It is suggested the installation engineer read this complete section before beginning tuning adjustments. After this he will be able to make proper adjustments for the particular coil combinations which will be used.

3.3. ADJUSTMENT PROCEDURE.

3.3.1. RF ADJUSTMENTS.

(a) Place the FILAMENT power switch in the ON position. Make certain the PLATE power switch is in the OFF position.

(b) Adjust the filament voltage of the modulator and the r-f final amplifier tubes to 5 volts as indicated on the FILAMENT VOLTAGE meter using the FIL VOLTAGE ADJUSTMENT knob located directly above the filament switch on the front panel.

NOTE

Permit the equipment to operate in this manner, with only the filament power turned on, for a period of 15 minutes. This will allow the 866A rectifier tubes to attain proper operating conditions. Such a procedure is necessary only when new rectifier tubes are placed in service.

- (c) Operate the PHONE-CW switch to the CW position. Set the AUDIO GAIN at 0.
- (d) Operate the REMOTE-LOCAL control switch to the LOCAL control position.
- (e) Operate CHANNEL selector switch to either CHANNEL 1 or CHANNEL 2. The channel selected will depend upon the position of the frequency determining components such as crystals and inductors.
- (f) Place the PLATE VOLTAGE control in the LV position.
- (g) Operate the PLATE switch to the ON position.
- (h) Press the TEST key.
- (i) Adjust the OSC PLATE TUNING control until maximum grid current is indicated on meter M103. If, after tuning the MULT PLATE TUNING, (see below) the 4-125A grid current is greater than 20 ma, turn the OSC PLATE TUNING control in the direction of decreasing dial numbers, thereby increasing capacity in the circuit which will decrease the drive to the 807 multiplier tube and reduce the 4-125A excitation.
- (j) Adjust the MULT PLATE TUNING control, for the channel which is being used, until maximum grid current is indicated by the PA GRID CURRENT meter. A reading of 12 to 20 ma should be obtained. If the final grid drive is too great it may be adjusted by detuning the OSC PLATE TUNING control slightly in the direction of smaller numbers on the dial scale (only when the output frequency is less than 6 mc).

NOTE

12 to 15 ma grid current is best, but any grid current from 10 to 20 ma will give satisfactory operation. These grid current values should be obtained with plate power on and at full load since the grid current may drop slightly when the PA is loaded in the higher frequencies.

(k) For carrier frequencies below 6 mc, neutralize the multiplier stage by adjusting MULT NEUT capacitors C-228 (channel 1) and C-229 (channel 2) in turn for symmetrical and minimum MULT GRID current reaction when turning the MULT PLATE tuning through resonance. Use an insulated screwdriver for adjusting C-228 and C-229. For frequencies above 6 mc, set the neutralizing capacitors at about 1/3 capacity.

(l) Set the ANTENNA TUNING and LOADING control at half capacity and with the PLATE VOLTAGE control in the TUNE position and the LOCAL-REMOTE control switch in the LOCAL position, apply PLATE power.

NOTE

Maximum capacity on all tuning dials is at "0" on the dial.

(m) Press the TEST key and immediately attempt to resonate the power amplifier plate tank circuit by operating the PA PLATE TUNING. Resonance will be indicated by a sharp dip in current on the PA PLATE CURRENT meter, M101. If resonance cannot be established, change the position of the inductor tap and make another attempt to resonate the circuit.

NOTE

If the tap on the inductor happens to fall in a position which leaves more than 50% of the turns unused, the unused portion should be shorted out. This is easily done by soldering a short piece of heavy bus between the cold end of the coil and the coil rider right at the lugs on the connector pins.

(n) Operate the TEST KEY and using the ANTENNA TUNING and LOADING control, load the power amplifier stage until the PA PLATE CURRENT meter indicates 80 ma. While increasing the loading with the ANTENNA TUNING and LOADING control, keep the tank circuit in resonance with the PA PLATE TUNING control.

(o) Operate the PLATE VOLTAGE control to the OPERATE position and repeat step (m) until the PA PLATE CURRENT meter indicates 200 ma.

(p) Repeat the above tuning procedure for the other frequency channel.

NOTE

Do not operate the CHANNEL selector switch with the PLATE power ON.

(q) The carrier frequency can now be adjusted to within .001% of specified frequency (providing specified crystals are used) by adjusting CRYSTAL FREQUENCY CONTROL capacitors C201 (channel 1) and C-202 (channel 2) reached from the rear of the r-f chassis.

3.3.2. VOICE OPERATION ADJUSTMENTS.

(a) TUNING ADJUSTMENTS - The tuning adjustments for type A3 emission are identical to those just outlined except that the r-f power amplifier should be loaded to 150 ma in step 3.3.1. (o). The PHONE-CW switch should be in the PHONE position.

CAUTION

Do not operate the PHONE-CW switch while the PLATE power is ON. Always turn the PLATE power switch to the OFF position before operating the PHONE-CW switch.

The modulator static plate current (no modulation) should be adjusted to 45 ma by rotating the MODULATOR BIAS control at the rear of the speech amplifier and modulator unit with the transmitter fully operating. This will have to be done by steps since opening the rear door operates the interlock switch and turns the plate power off.

CAUTION

When applying plate power to the modulator tubes for the first time, immediately check the modulator static (resting) plate current. If over 45 ma, adjust before attempting further operation; otherwise, the modulators may become damaged.

(b) AUDIO ADJUSTMENTS.

(1) REMOTE CONTROL ADJUSTMENTS - This transmitter has been designed for remote operation from a type 177L-2 Remote Control Unit. The distance from which the transmitter may be controlled is determined by the line loss. The loss in the line cannot exceed 25 db. The procedure outlined below should be followed in making preliminary adjustments.

(a) Apply filament and plate to the tubes in the 177L-2 unit by operating the ON-OFF switch to the ON position. (The transmitter FILAMENT and PLATE switches must be in the ON positions at all times REMOTE operation is desired.)

(b) When the tubes in the remote control unit have reached operating temperature, rotate the 177L-2 gain control in a clockwise direction until the AUDIO LEVEL meter, M801, indicates 0 db (zero level corresponds to 6 mw into 600 ohms) on peaks when talking in a normal tone into the microphone.

(c) With the transmitter AUDIO GAIN control set at 1/3 position, adjust the audio control R701 in the 175V-2 Relay Unit for desired modulation. (When speaking into the remote microphone.)

(2) TRANSMITTER ADJUSTMENTS.

(a) SPEECH CLIPPER OUT - The percentage of modulation at which speech clipping occurs has been chosen at 100% and the modulation control locked at the factory. If speech clipping is not desired, merely adjust the AUDIO GAIN control on the front panel until approximately 125 ma MODULATOR PLATE current is obtainable on heavy modulation peaks.

In the event speech clipping is dispensed with entirely, the 6H6 clipper tube can be removed from its socket in the modulator unit. This is not recommended however, since the clipper does prevent overmodulation.

(b) SPEECH CLIPPER IN - The clipper level adjustment on the rear of the speech unit was set at the factory using the following procedure. The transmitter was loaded for normal power input and a 400 cycle sine wave audio tone fed into the microphone input. The clipper level adjustment was then set at approximately 1/5 turn back from the full clockwise position. The AUDIO GAIN control was then advanced until approximately 75% modulation was observed on an oscilloscope screen, after which the audio input was increased just 12 db and the clipper level control adjusted so that 100% modulation was reached. This procedure is repeated if necessary so that 12 db increase in audio level raises modulation to just under 100%.

The amount of speech clipping can be adjusted by the AUDIO GAIN control. With the control in an advanced position, a greater amount of sideband power is obtained because of the high modulation average. With the control set thus, however, a

quiet operating position is desirable because of the higher overall audio gain with resulting higher room noise. Where the background noise is objectionable a noise-canceling microphone is recommended.

NOTE

Since clipping over 6 db results in less desirable quality, even though the intelligibility may be better for working through interference, the signal should be monitored and the audio gain adjusted to the point which produces a balance between more audio power and good quality.

3.4. TYPICAL METER READINGS.

3.4.1. PHONE EMISSION

PA PLATE CURRENT - 150 ma

PA GRID CURRENT - 12-15 ma

MULTIPLIER GRID CURRENT - 0-4 ma

MODULATOR PLATE CURRENT - STATIC - 45

100% MOD (Sine wave) - 150 ma

FILAMENT VOLTAGE - 5 V

3.4.2. CW EMISSION

PA PLATE CURRENT - 200 ma

PA GRID CURRENT - 12-15 ma

FILAMENT VOLTAGE - 5 V

MULTIPLIER GRID CURRENT - 0-4 ma

SECTION 4 CIRCUIT DESCRIPTION

4.1. GENERAL.

The Collins Type 30K-5 has two r-f channels, each of which may be pretuned to any frequency between 2.0 and 30.0 mc. Switching from one to the other is accomplished instantaneously by means of relays. A stable crystal controlled oscillator is followed by a stage employing an 807 tube which serves as a buffer, doubler and driver. A single high efficiency tetrode is used in the output stage. The audio circuit is designed especially for voice communication.

4.2. PRIMARY POWER CIRCUITS.

Refer to figure 4-1. The filament transformers T201, T303, T403 and T501, bias supply transformer T401 and relay voltage transformer T102 are energized when the FILAMENT switch, S105, is closed. The FILAMENT switch disconnects all power to the transmitter and must be on for REMOTE as well as LOCAL operation. Each of the above transformers is protected by a fuse. The filament voltage applied to the modulator and r-f power amplifier tubes may be adjusted by operation of S104. The low voltage transformer T402 and high voltage plate transformer T101 are energized by operation of plate relay K401 which is operated when the PLATE switch is closed. Because the relay coil energizing voltage is obtained from the bias supply, the possibility of applying plate power to modulator and r-f power amplifier with no fixed bias present is eliminated. A plate primary interlock switch, S108, is operated by the rear access door. When placed in the TUNE position the PLATE VOLTAGE CONTROL switch, S102, reduces the primary voltage on the high voltage plate transformer, T101, during the tuning procedure.

NOTE

The door interlock switch, S108, should not be made inoperative under any circumstances.

4.2.1. RECTIFIER POWER SYSTEM. - The type 30K-5 employs three separate d-c power circuits. These consist of a bias supply, a low voltage supply for the speech amplifier and low level r-f stages, and a high voltage supply for the modulator and r-f power amplifier stages. The bias supply employs a type 5R4GT tube, V401. The d-c output of the supply is approximately -145 volts. Provision is made for bias voltage adjustment on the modulator grids. The low voltage plate supply uses a 5R4GY tube, V402, in the rectifier circuit. The d-c output voltage is approximately 500 volts. The high voltage supply employs two type 866A tubes in a single-phase full-wave rectifier circuit. It supplies plate power to the r-f power amplifier and modulator tubes. The d-c output voltage of the high voltage supply is 2500 volts.

4.3. CARRIER CONTROL CIRCUITS.

The carrier control circuits of the transmitter are outlined in figure 4-2. The CHANNEL switch, S102, will function only when the LOCAL-REMOTE switch, S103, is in the LOCAL position. When S103 is in the REMOTE position, the desired channel

may be selected from the remote control unit. When S103 is in the LOCAL position the key circuit is made operative and the auxiliary plate relay, K702, contacts are shorted allowing the transmitter plate switch, S106, to have control; the filament relay, K701 circuit is closed so the transmitter FILAMENT switch, S105, will remove all filament power. The keying relay, K201, interrupts the crystal oscillator plate and the mult. screen circuits. The plate voltage relay, K401, receives its energizing voltage from the bias supply and will not operate until bias voltage is being applied to the modulator and r-f power amplifier tubes. 2-1/2 pair of telephone lines and ground return are used to connect the type 177L-2 Remote Control Unit and the transmitter. The resistance of any wire and ground return should not exceed 200 ohms. If the operating controls (microphone, push-to-talk switch, key, relay control) are located at a distance no greater than 50 feet from the transmitter, a remote control unit will not be required.

4.4. RF CIRCUITS.

4.4.1. OSCILLATOR. - A type 6AG7 tetrode, V201, is employed in a stable crystal controlled oscillator circuit. The proper crystal for operation on either channel one or channel two is selected by contacts on relay K206. A group of contacts on relay K202 connect the desired oscillator plate tank components in the circuit. Screen voltage for the oscillator is supplied through the dropping resistor, R203.

4.4.2. MULTIPLIER. - The multiplier stage uses a type 807 tube, V202. Grid current is indicated by M102. A voltage divider composed of resistors R209 and R210 supplies screen voltage for the exciter tubes.

4.4.3. RF POWER AMPLIFIER. - The r-f amplifier uses a high efficiency tetrode. The proper grid circuit components are connected in the circuit by relay, K203. The desired output network is connected by relay, K204.

4.4.4. RF OUTPUT CIRCUIT. - The output circuit employed in the 30K-5 Transmitter consists of a pi section plate tank circuit. It is designed to operate over the frequency ranges 2000 to 30,000 kc by means of plug-in coils. It is designed to operate into an unbalanced transmission line or antenna. A jack bar is provided to plug in a load coil to reach 50 ohms on frequencies between 2 and 4 mc.

4.5. AUDIO CIRCUITS.

4.5.1. GENERAL. - A high gain preamplifier is followed by a two-stage audio amplifier which is shunted by a peak clipper tube. The output of the amplifier is followed by the modulator driver stage, which in turn is followed by the class B modulator. Full 100% modulation is attained with the use of any high impedance microphone such as a crystal or high impedance dynamic. The peak clipper limits or clips both the negative and the positive audio peaks, (if clipping is desired) thus preventing overmodulation while allowing a more powerful sideband to be transmitted. A low-pass filter attenuates all speech frequencies over 4000 cps.

4.5.2. SPEECH AMPLIFIER CIRCUITS. - A type 6SJ7 pentode, V301, is employed as a high gain voltage amplifier. Following the preamplifier is a type 6SN7 dual triode tube, the first section of which precedes the 6H6 clipper tube. Refer to figure 4-3. The type 6H6 clipper tube, V303, is shunted across the audio input to the second section of the type 6SN7 audio amplifier tube. The cathode of one section of the type 6H6, pin number 4, is operated at a small fixed value of positive potential by virtue of being connected through reactor L301, resistor

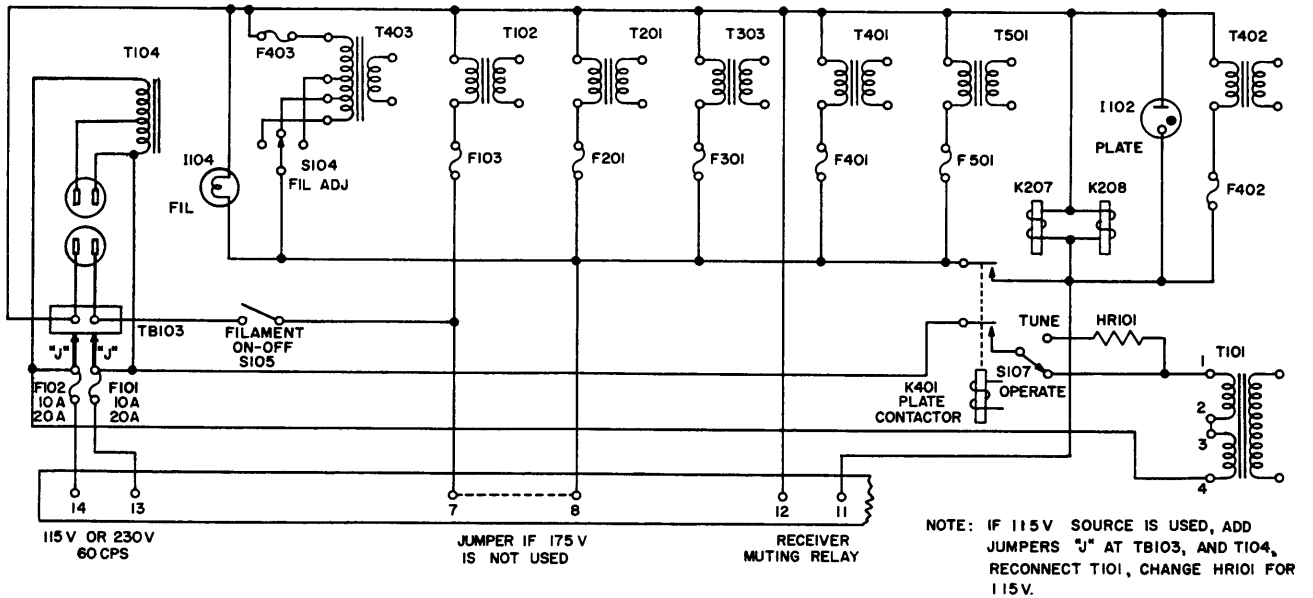

Figure 4-1. Primary Power Circuit

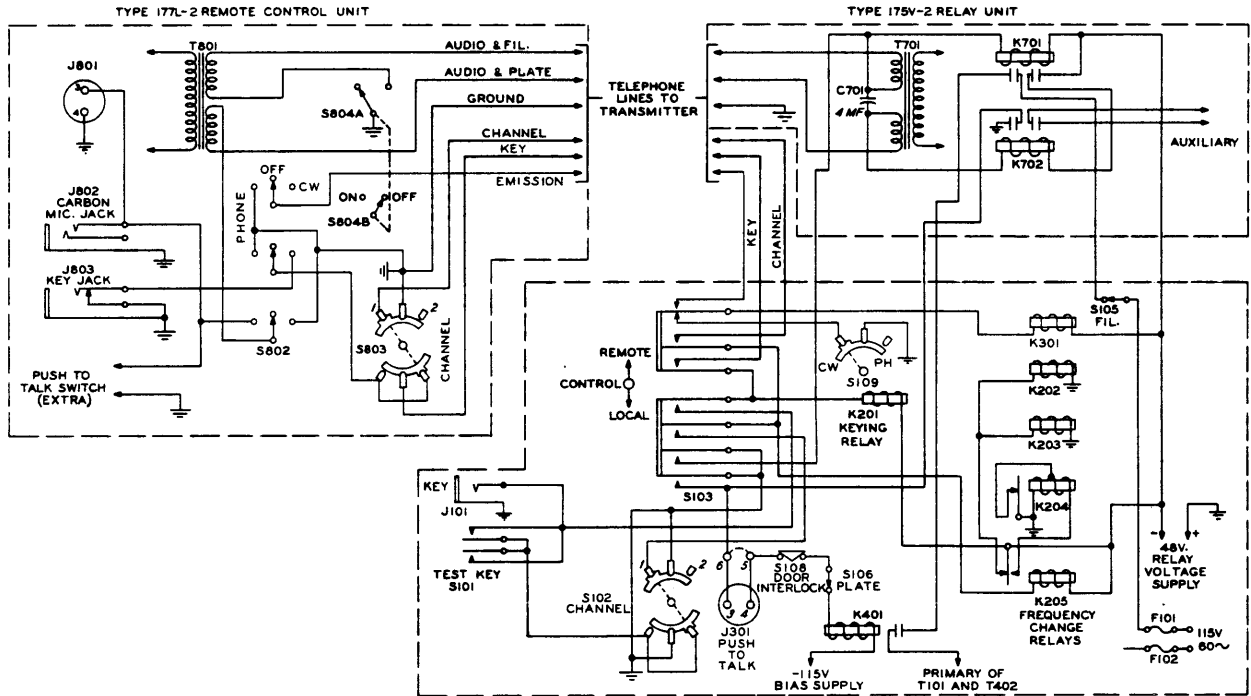

Figure 4-2. Carrier Control Circuits

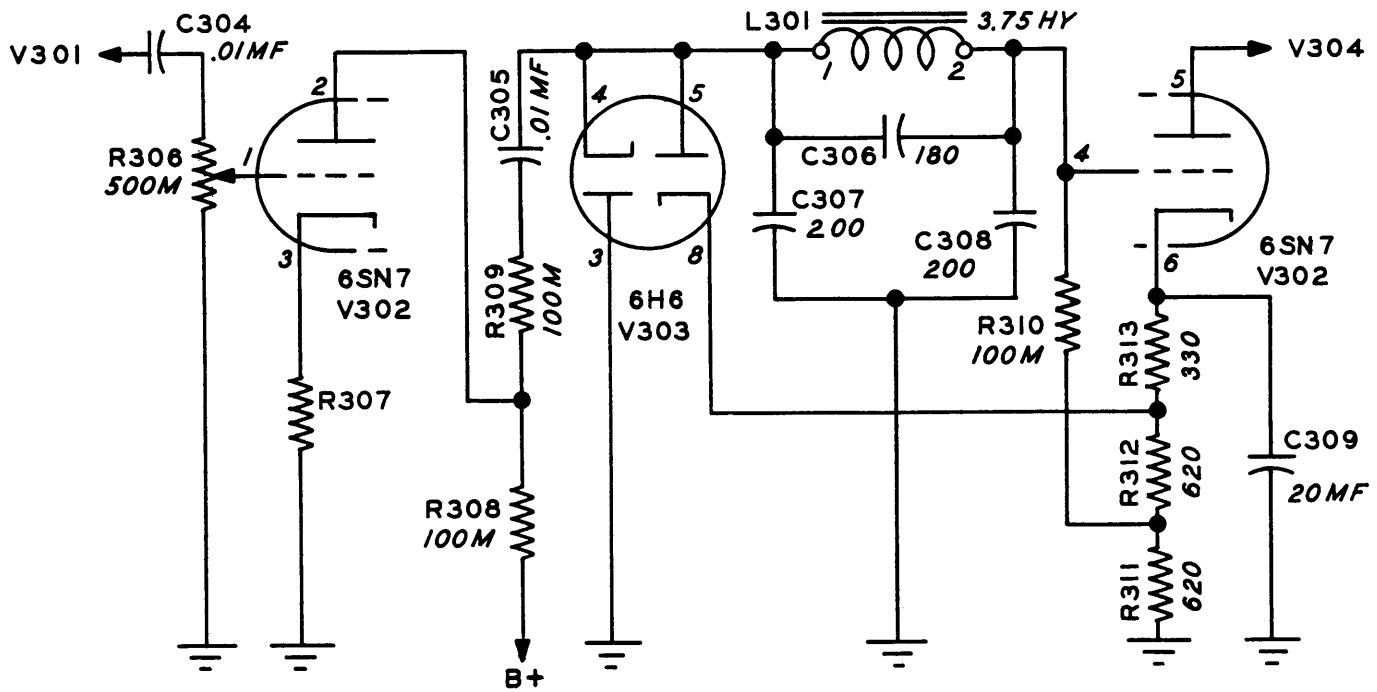

Figure 4-3. Audio Peak Clipper Circuit

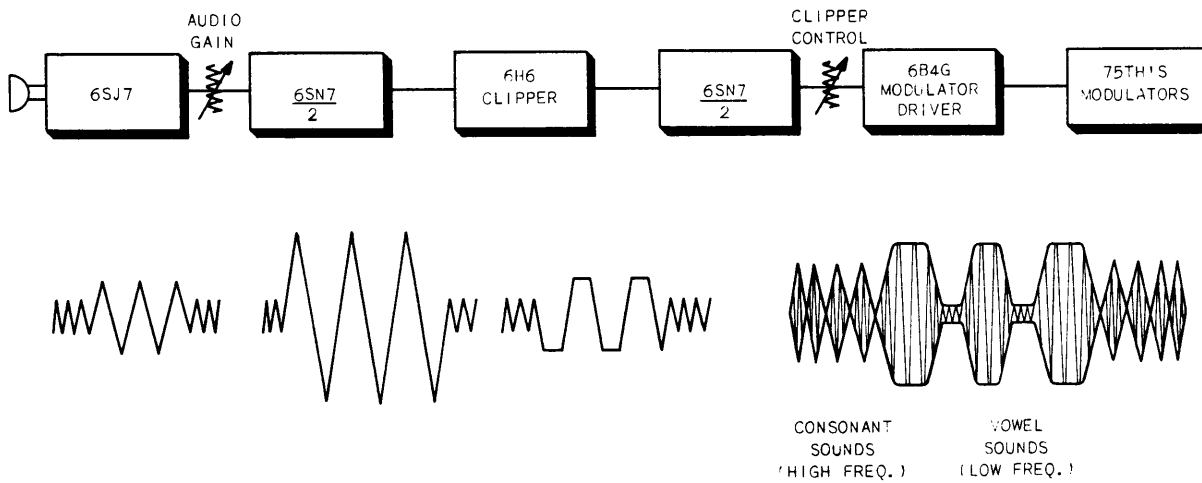

Figure 4-4. Clipper Waveform Illustration

R310 to a tap on the cathode resistors R311, R312, and R313. This positive cathode potential biases the corresponding diode plate and no current flows through this section of the tube. However, when the magnitude of the negative audio peaks applied to the diode cathode become large enough to overcome the fixed positive potential, current flows through this section of the diode and the negative audio peak is limited or clipped by the short circuiting action of the diode. Likewise, the cathode of the second section of the clipper tube is returned to a tap on the type 6SN7 amplifier cathode resistor which is more positive than the tap where its corresponding plate is attached. Thus the plate of the second section of the type 6H6 is more negative than the cathode and no current flows. When a positive audio peak of sufficient magnitude reaches this diode plate the fixed negative bias is overcome and current flows through the second section of the diode and the positive audio peak is limited or clipped. Because of the above action, the audio output of the second section of the audio amplifier tube cannot rise above the fixed level. Therefore, it is possible to set the degree of maximum modulation with the peak clipper control, R315, and to be assured that the percentage of modulation will not rise above the chosen amount.

4.5.3. MODULATOR DRIVER CIRCUITS. - The output from the second section of the type 6SN7 dual triode tube is coupled to the grid of the driver tube, V304, through capacitor C310 and the clipper control R315. A type 6B4G power amplifier triode, drives the grids of the class B modulator tubes through transformer T301.

4.5.4. MODULATOR CIRCUIT. - A pair of type 75 TH triode power amplifier tubes are employed as modulators operating in class B service. Excitation for the modulator grids is obtained through the driver coupling transformer T301. Both the screen and the plate of the r-f power amplifier tube are modulated by individual secondary windings on the modulation transformer T302. When switching to cw emission, the modulator filaments are turned off and the power amplifier plate winding in the modulation transformer is short-circuited. Plate voltage for the audio amplifier and driver stages is obtained from the low voltage supply while plate voltage for the modulator tubes is obtained from the high voltage supply. Screen voltage for the power amplifier tube is also taken from the low voltage supply. Grid bias for all audio tubes except the modulators is obtained from cathode resistors. The modulators are biased by voltage from the bias supply. A potentiometer, R401, located at the rear of the low voltage power supply unit, is used for adjustment of the modulator bias.

NOTES

SECTION 5 MAINTENANCE

This radio equipment is constructed of materials considered to be the best obtainable for the purpose, and has been carefully inspected and adjusted using accurate test equipment. No one but an authorized and competent service technician equipped with proper test facilities should be permitted to service the equipment.

5.1. ROUTINE INSPECTION SCHEDULES.

Routine inspection schedules should be set up for periodic checks of the equipment. This inspection should include examination of the mechanical system for excessive wear or binding and of the electrical system for electrical defects. Make a check of the emission characteristics of all tubes. See that all tubes are replaced correctly and fully in their sockets, and that good electrical contact is made between the prongs of the tube and socket. Check all relays for proper operation and inspect relay contacts to make certain that the contact surfaces are clean and free from pits and projections. Make certain that contacts of all receptacles and plugs, such as microphone, key and cable connectors, are clean and make firm mechanical connections between one another. If the routine inspection of the equipment is carried out faithfully, the chances of improper operation of the equipment is greatly minimized. It is, therefore, important that this inspection be made at least once each month and it should be sufficiently thorough to include all major electrical circuits of the equipment.

5.1.1. CLEANING. - The greatest enemy to uninterrupted service in equipment of this type is corrosion and dirt. Corrosion itself is accelerated by the presence of dust and moisture on the component parts of the assembly. It is impossible to keep moisture out of the equipment in certain localities but foreign particles and dust can be removed by means of a soft brush and dry, oil-free jet of air. Remove the dust as often as a perceptible quantity accumulates in any part of the equipment. It is very important that rotating equipment, such as variable condensers and tap switches, be kept free of dust to prevent undue wear. Likewise, variable condenser plates should be kept free from dirt to avoid flash-over on modulation peaks.

One of the predominant sources of trouble in equipment located in a salt atmosphere is corrosion. Corrosion resulting from salt spray or salt laden atmosphere may cause failure of the equipment for no apparent reason. In general, it will be found that contacts such as tap switches, tube prongs, cable plug connectors and relay contacts are most affected by corrosion. When it is necessary to operate the equipment in localities subject to such corrosive atmosphere, inspection of wiping contacts, cable plugs, relays, etc., should be made more frequently in order to keep the equipment in good condition.

5.1.2. VACUUM TUBES. - Make a check of emission characteristics of all tubes. After the emission check, examine the prongs on all tubes to make sure that they are free from corrosion. See that all tubes are replaced correctly and fully in their sockets, and a good electrical contact is made between the prong of the tube and socket. Use caution in removing and replacing grid or plate caps on tubes. Before a tube is discarded, make certain that the tube is at fault and the trouble

is not a loose or broken connection within the equipment. A complete set of tested tubes of the same type specified should be kept on hand at all times. If faulty operation of the transmitter is observed and tube failure suspected, each tube may be checked by replacing it with a tube known to be in good condition. Defective tubes causing an overload in power circuits may usually be located by inspection. It will be found that excessive heating or sputtering within the vacuum tubes is a good indication of a fault in the tube circuit.

If tubes have been in use for a period of time equal to or exceeding the manufacturer's tube life rating, it is suggested that they be replaced. A marked improvement in the performance of the equipment is usually noticeable after the weak tubes have been replaced.

(a) PRECAUTIONS FOR SATISFACTORY TUBE LIFE.

(1) Before any tube is removed from the equipment, make certain the primary power is disconnected from the equipment.

(2) Operate all tubes within $\pm 5\%$ of rated filament voltage.

(3) Do not exceed the rated plate current of any tube during normal operation of the equipment.

(b) TUBE REPLACEMENT PRECAUTIONS.

(1) All tubes are removed by pulling straight up on them.

(2) Remove plate cap connectors with great care to prevent breaking the seal around the plate cap.

(3) Before the tube is inserted, make certain that the type of tube is correct for the socket into which it is being placed.

5.1.3. RELAYS. - All relays should be inspected at regular intervals. Check the contacts for proper alignment, pitting and corrosion. Use a burnishing tool to clean contacts, never use sandpaper or emery cloth..

5.2. TROUBLE SHOOTING.

5.2.1. GENERAL. - If the section of the equipment in which the fault occurs can be isolated, the trouble may be located with a minimum of effort. Continuity checks and voltage measurements in circuits still operative may be helpful in isolating the trouble. For this purpose, an a-c, d-c voltmeter having an internal resistance of not less than 20,000 ohms per volt and equipped with a battery for continuity and resistance measurements is necessary. An oscilloscope is very useful in tracing faults in r-f and a-f circuits.

A frequent cause of trouble in equipment of this type is tube failure. If trouble occurs in the equipment, isolation of the circuit at fault is helpful in determining the location of the defective tube. Defective tubes which cause an overload in power circuits may usually be located by inspection. Low emission tubes may be the cause of erratic or poor performance of the equipment. If there is any doubt concerning the emission of any tube, it should be checked and immediately replaced if found defective. Tubes with electrical noises can cause excessive

distortion or hum. This fault may be difficult to isolate to a particular tube. However, a tube suspected of faulty operation may be checked by replacing with a like tube known to be in good condition.

5.2.2. ISOLATING THE TROUBLE.

(a) Check the position of all controls to determine if they have been accidentally moved from the normal operating position.

(b) A check of all fuses should be made to determine the power circuit affected by the trouble. Fuse failure should be replaced only after the circuit in question has been carefully examined to make certain no permanent fault exists. Always use fuses with ratings as specified in the following table:

<u>FUSE TABLE</u>			
<u>Symbol</u>	<u>Circuit Location</u>	<u>Type</u>	<u>Rating</u>
F101	Primary power source line	Screw base	20 amp
F102	Primary power source line	Screw base	20 amp
F103	Relay voltage supply transformer primary	Cartridge Slo-Blo	1/2 amp
F201	Exciter filament transformer primary	Cartridge Slo-Blo	1/2 amp
F301	Speech amplifier filament transformer primary	Cartridge Slo-Blo	1/2 amp
F401	Bias supply transformer primary	Cartridge (3AG)	1/2 amp
F402	LV power supply transformer primary	Cartridge (3AG)	3 amp
F501	HV rectifier filament transformer primary	Cartridge (3AG)	1 amp
F801	Type 177L-2 Remote Control Unit	Cartridge (3AG)	1/4 amp

(c) Check the circuits in the sequence by which they are made operative in starting the transmitter.

(d) Compare the transmitter meter readings with the typical readings given under operational data in section 3.

(e) Make a visual inspection of all tubes, resistors and chokes. Tubes may be sputtering indicating shorts or their plates may show color indicating a heavy current drain. Resistors and chokes may be discolored by passing large amounts of current.

5.2.3. POWER SUPPLY TROUBLE. - The following chart lists troubles often encountered in power supply systems and causes and corrections of each:

(a) FAILURE OF FILAMENT SUPPLY VOLTAGE.

<u>Symptoms</u>	<u>Possible Cause of Trouble</u>	<u>Remedy</u>
1. No filament voltage applied to any one certain tube in the equipment.	1. a. Associated fuse in primary circuit is open. b. Defective filament transformer.	1. a. Replace fuse. b. Replace transformer if found to be defective.
2. Filament pilot lamp does not light.	2. Filament pilot lamp defective.	2. Replace lamp.

(b) FAILURE OF PLATE VOLTAGE SUPPLY. - High voltage supply does not come on when PLATE supply switch is operated.

<u>Symptoms</u>	<u>Possible Cause of Trouble</u>	<u>Remedy</u>
1. Plate pilot lamp does not light and the meters indicate no plate current on modulators or power amplifiers.	1. a. Defective plate relay, K401. 2. Defective door switch. 3. Defective plate switch. 4. If 177L-2 used: Open telephone line or defective plate switch or push-to-talk button.	1. Replace component if found defective. 2. Same as above. 3. Same as above. 4. Same as above.

(c) LV OR BIAS VOLTAGE SUPPLY FAILURE.

<u>Symptoms</u>	<u>Possible Cause of Trouble</u>	<u>Remedy</u>
1. No indication of plate or screen voltages on oscillator, multiplier or audio amplifier tubes.	1. a. Fuse, F402, is open. b. Defective rectifier tube, V402. c. Open filter choke, L402. d. Shorted filter capacitors.	1. In the event a defective component is isolated, it should be replaced with one known to be in good condition.
2. No bias voltage on modulators or r-f final amplifier tubes.	2. a. Fuse, F402, is open. b. Defective rectifier tube V401. c. Open filter choke, L401. d. Shorted filter capacitors.	2. In the event a defective component is isolated, it should be replaced with one known to be in good condition.

5.2.4. RADIO FREQUENCY TROUBLE.

<u>Symptoms</u>	<u>Possible Cause of Trouble</u>	<u>Remedy</u>
1. No drive to PA.	1. a. Defective crystal. b. Defective tube, open r-f coil. c. Channel change relay contacts dirty.	1. a. Replace crystal. b. Replace defective component. c. Burnish contacts.
2. PA does not resonate.	2. a. Antenna or transmission line characteristics changed.	

5.2.5. AUDIO SYSTEM TROUBLES.

(a) DISTORTION. - Very little distortion, except when clipping, is likely to occur with this equipment. However, if distortion is at all noticeable, the following checks should help to locate and correct it:

Check the static plate current on the modulators. This current should be approximately 45 ma for best operation. This value can be obtained by adjusting the bias on the modulators.

Replace the audio amplifier tubes with tubes known to be good.

Distortion may sometimes be difficult to locate. It may require a step by-step method of testing with the oscilloscope until the point is reached where the distortion occurs.

5.3. REPLACEMENT OF PARTS.

The detailed tabular parts list which follows in the next section of this instruction book will aid in the choice of correct replacement parts.

5.4. CRYSTAL DATA.

Crystal specifications are given in Table 1-4, SPECIFICATIONS.

TABLE 5-1
RESISTANCE MEASUREMENTS

Tube Pins to Ground

Conditions:

1. All tubes removed.
2. No power on unit.
3. Values in ohms unless otherwise indicated.

TUBE	Pin 1	Pin 2	Pin 3	Pin 4	Pin 5	Pin 6	Pin 7	Pin 8
4-125A V203	0.1	12,000	7,400	12,000	0.1		Plate Cap ∞	
8C7 V202	0.1	∞	46,000	530	0.0		Plate Cap 7,300	
6AG7 V201	0.0	0.1	0.0	105,000	0.0	50,000	0.0	∞
6SJ7 V301	0.0	770	1,030	1 Meg	1,030	500,000	770	180,000
6SN7 V302	9,000	84,000	1,100	107,000	72,000	3,200	770	770
6H6 V303	0.0	780	0.0	19,000	19,000		770	1,700
6B4G V304		770	11,000		92,000		770	
75TH V305	∞			0.1		Grid Cap 2,000		Plate Cap 93,000
75TH V306	0.1			∞		Grid Cap 2,000		Plate Cap 93,000
5R4G V401		0.0		2,800		2,700		0.2
5R4G V402		7,200		72		80		7,200
866 V501	125			125		Plate Cap 150		
866 V502	125			125		Plate Cap 170		

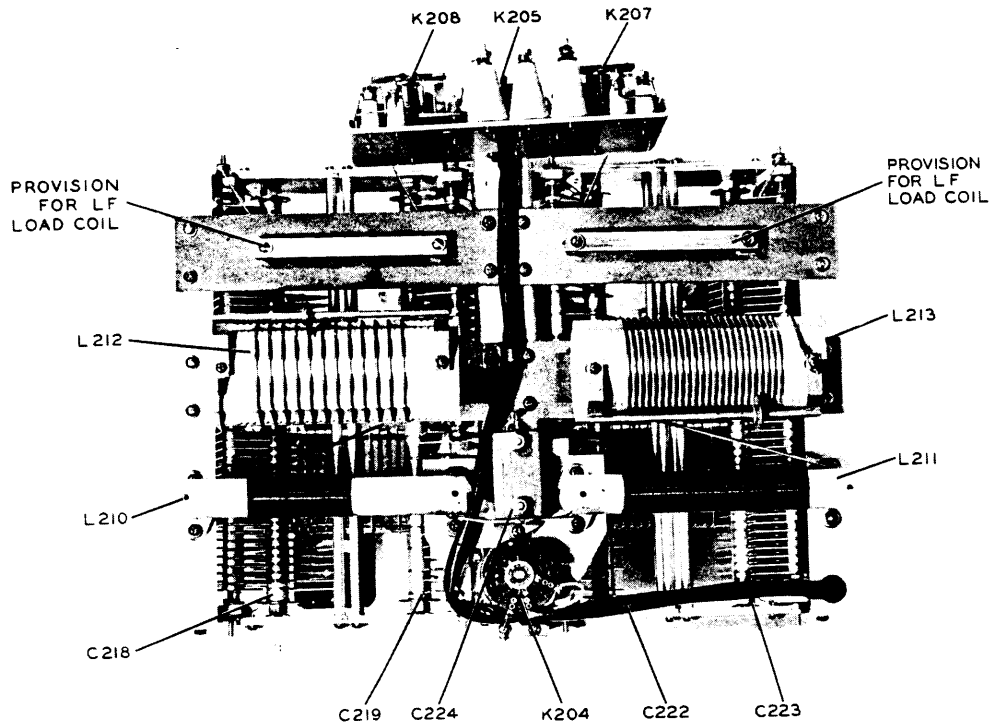

Figure 5-1. RF Output Network, Parts Arrangement - Top

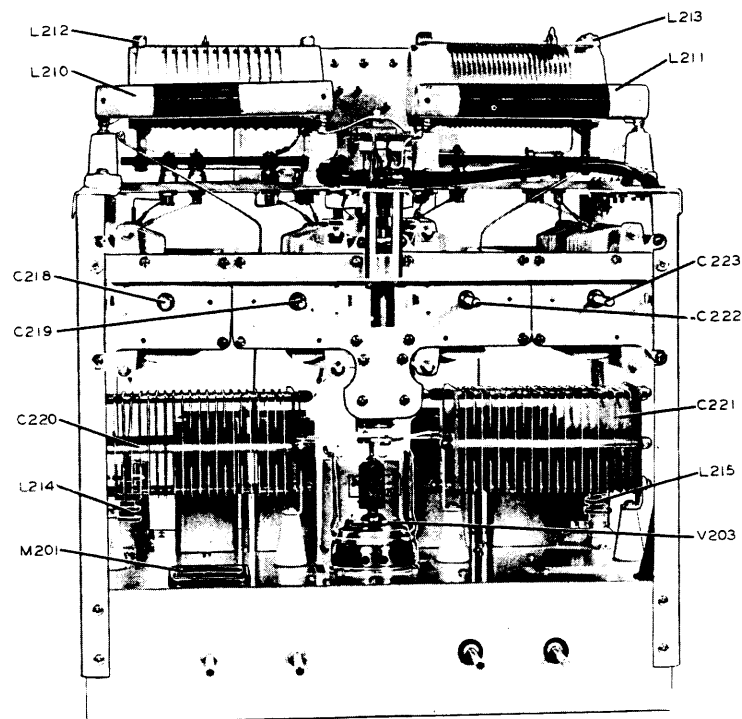

Figure 5-2. RF Exciter, Amplifier and Output Network, Parts Arrangement - Front

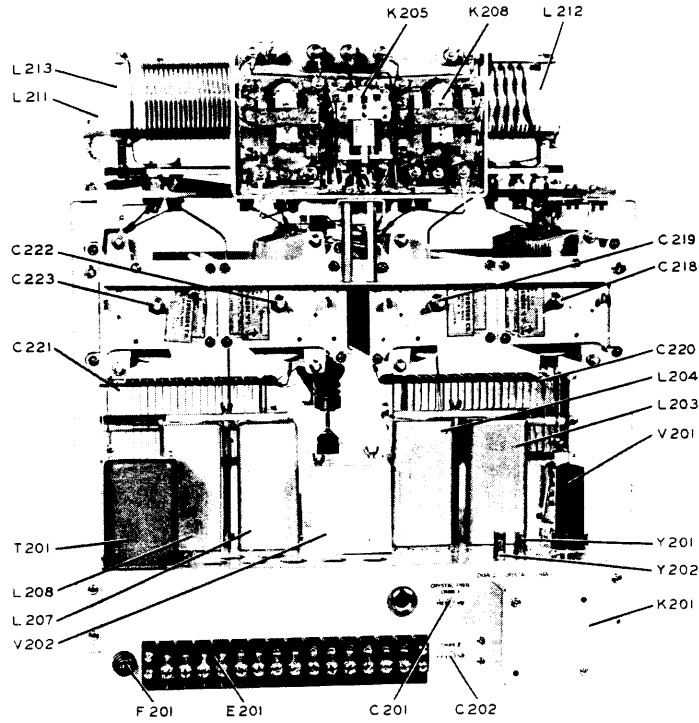

Figure 5-3. RF Exciter, Amplifier and Output Network, Parts Arrangement - Rear

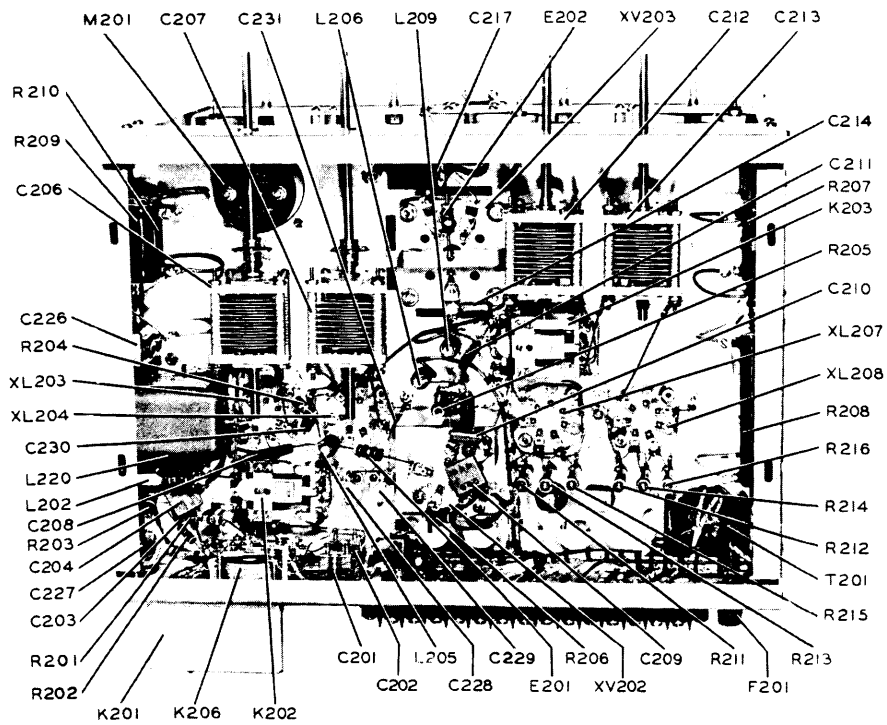

Figure 5-4. RF Exciter, Amplifier and Output Network, Parts Arrangement - Bottom

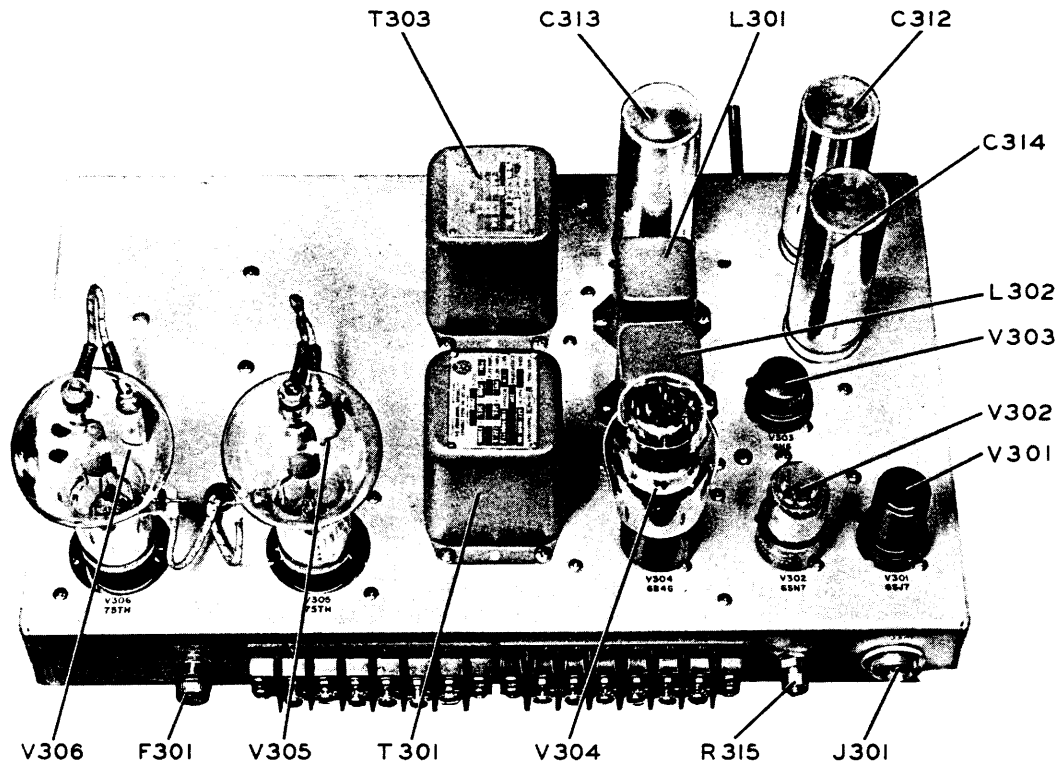

Figure 5-5. Speech Amplifier and Modulator, Parts Arrangement - Top

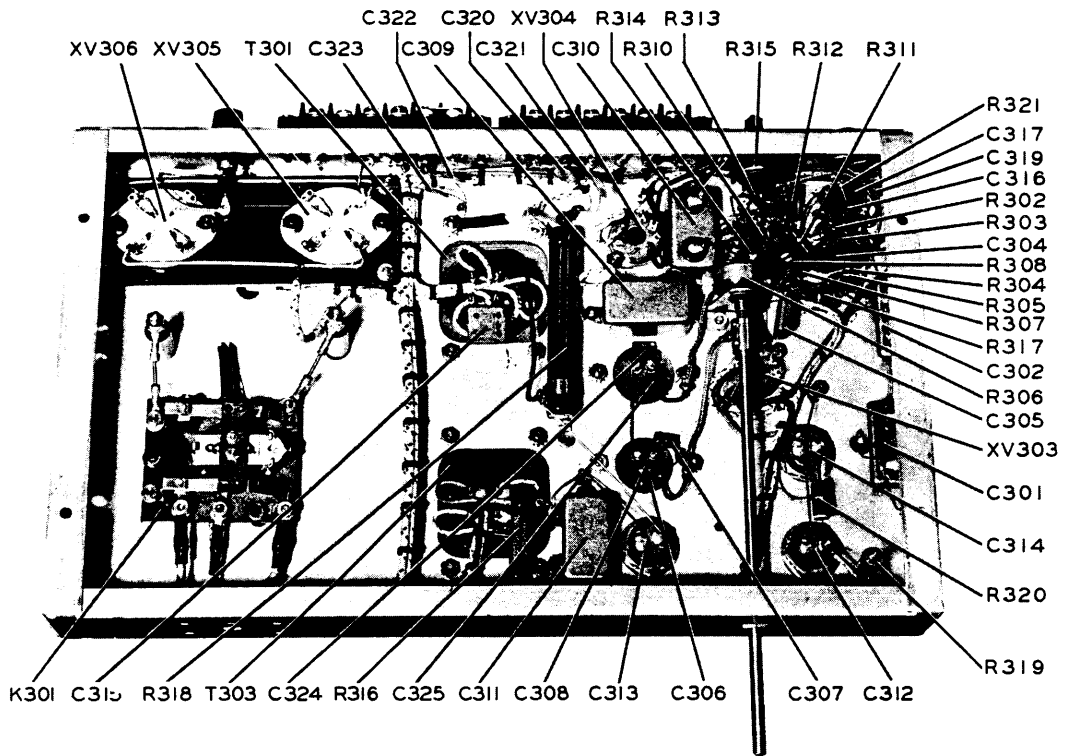

Figure 5-6. Speech Amplifier and Modulator, Parts Arrangement - Bottom

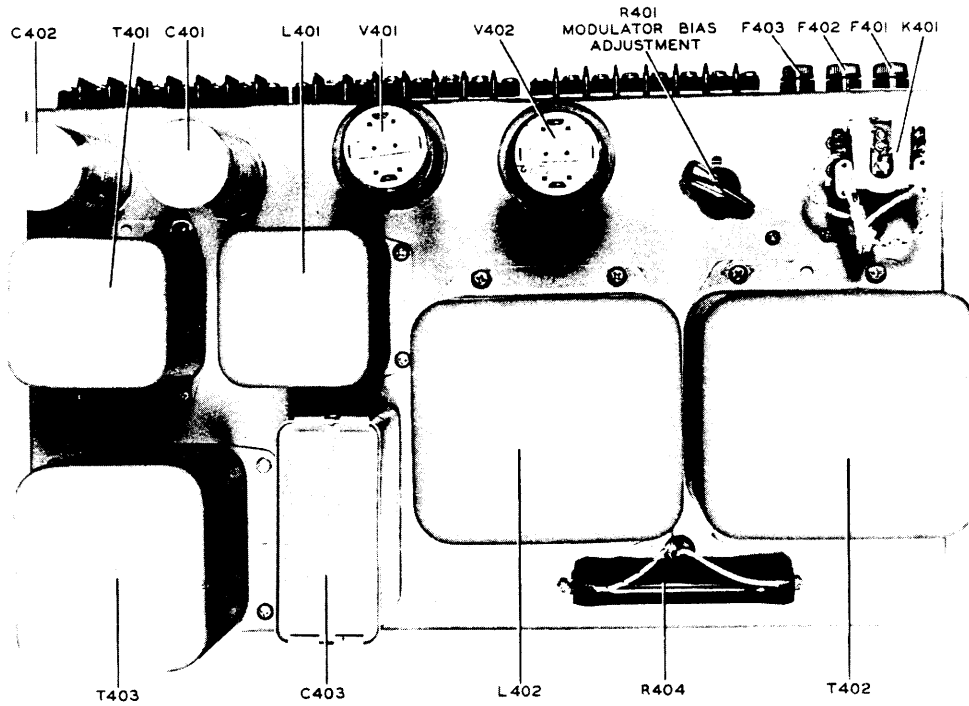

Figure 5-7. Low Voltage and Bias Power Supply, Parts Arrangement - Top

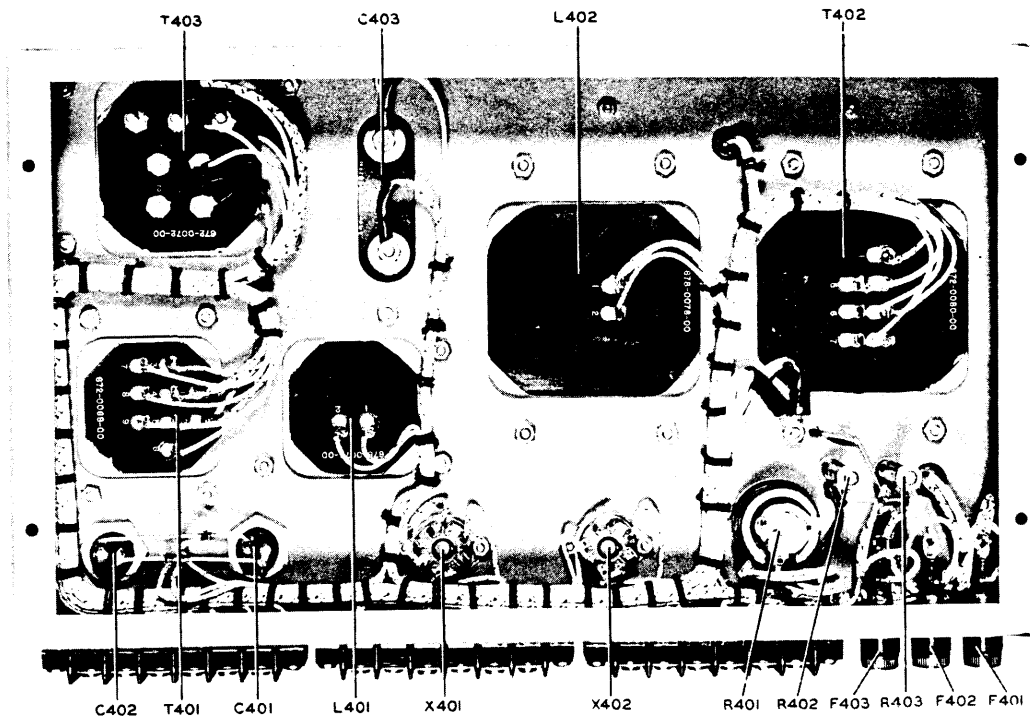

Figure 5-8. Low Voltage and Bias Power Supply, Parts Arrangement - Bottom

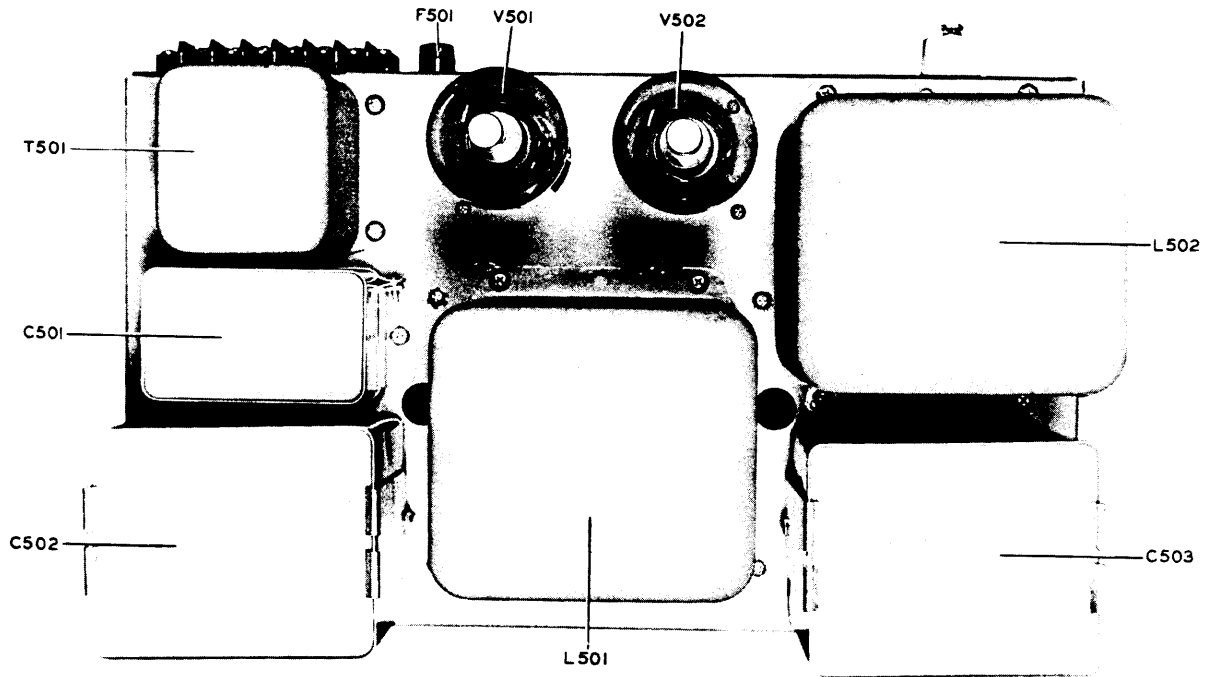

Figure 5-9. High Voltage Rectifier and Filter, Parts Arrangement - Top

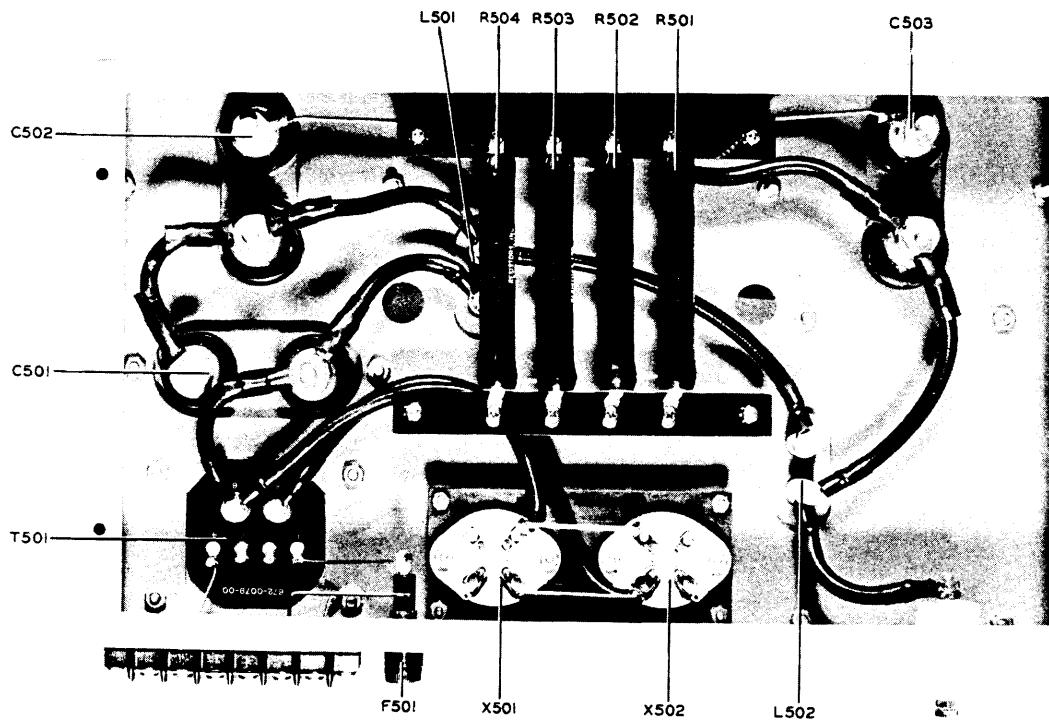

Figure 5-10. High Voltage Rectifier and Filter, Parts Arrangement - Bottom

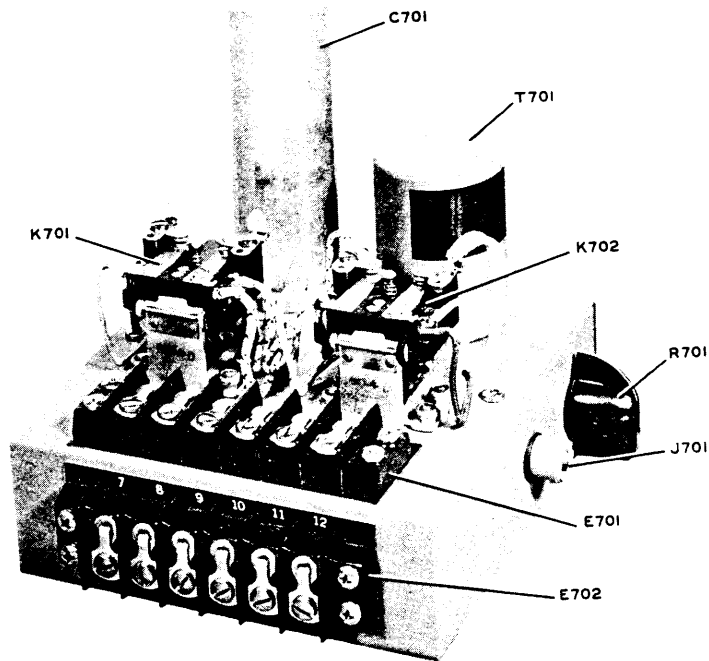

Figure 5-11. Type 175V-2 Relay Unit, Parts Arrangement - Top

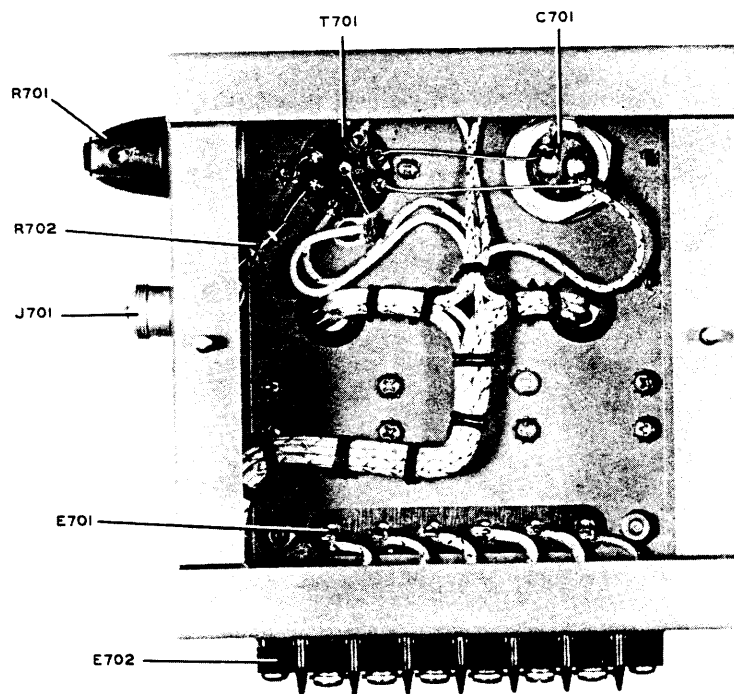

Figure 5-12. Type 175V-2 Relay Unit Parts Arrangement - Bottom

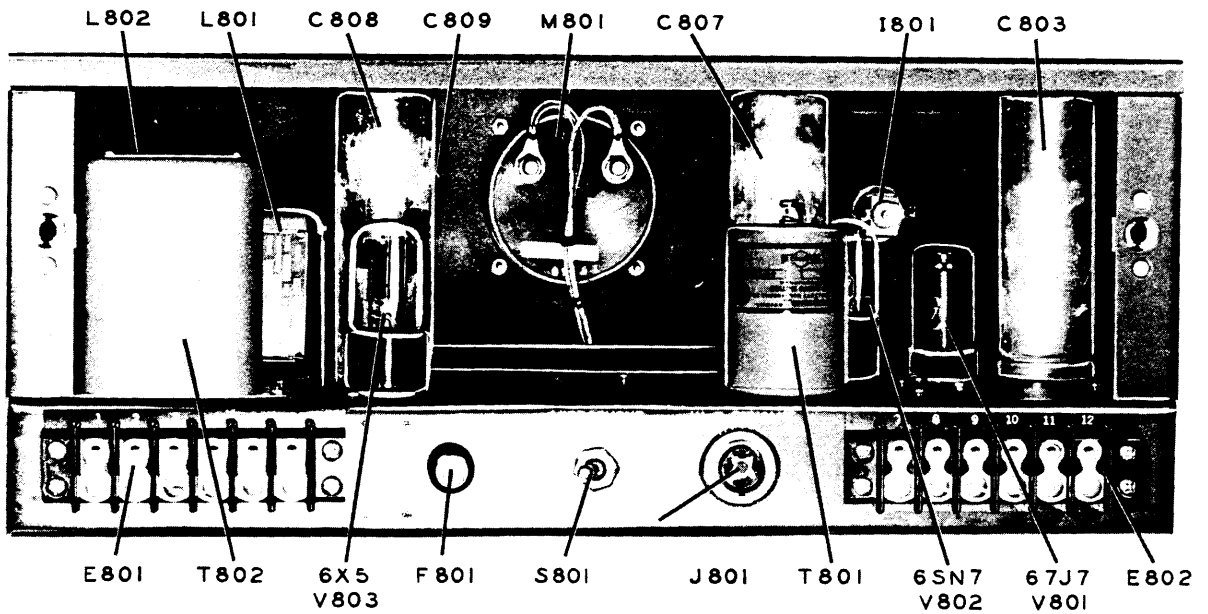

Figure 5-13. Type 177L-2 Remote Control Unit, Parts Arrangement - Top

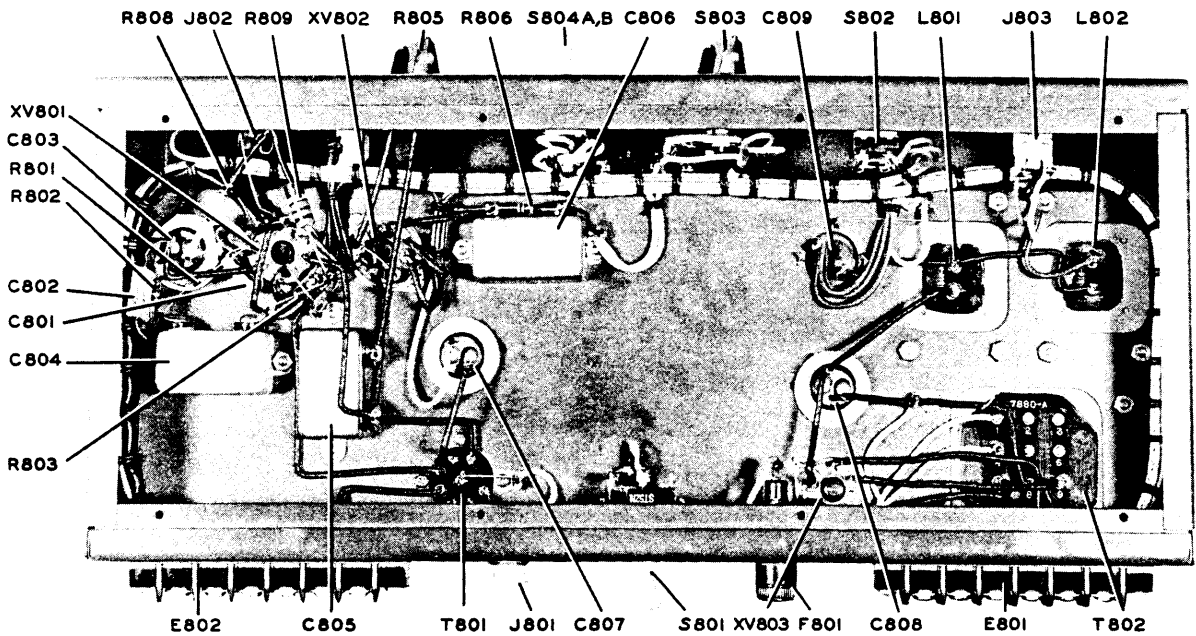

Figure 5-14. Type 177L-2 Remote Control Unit, Parts Arrangement - Bottom

NOTES

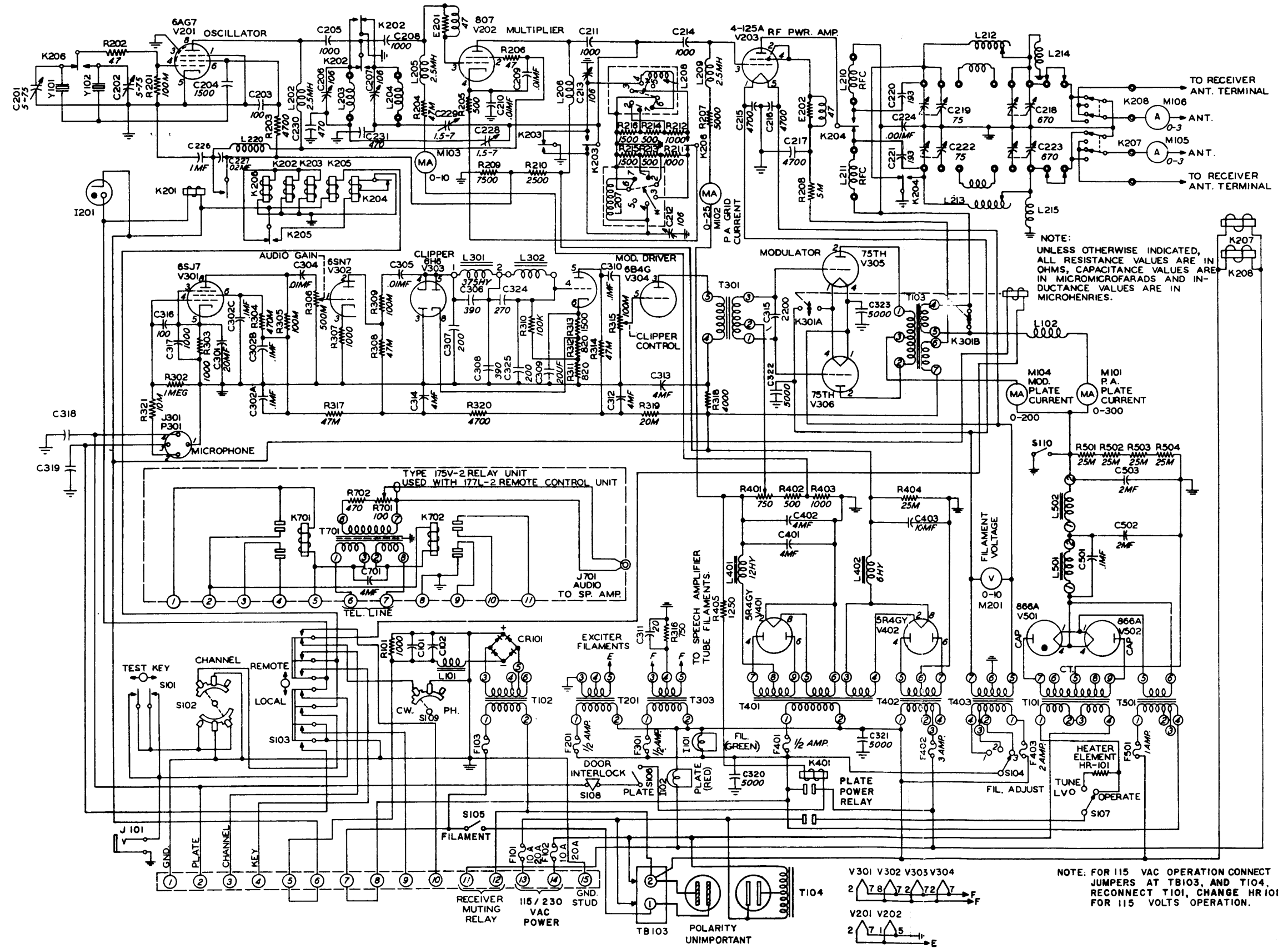

Figure 5-15. Type 30K-5 Transmitter, Complete Schematic (Shown Wired for 230-V Operation)

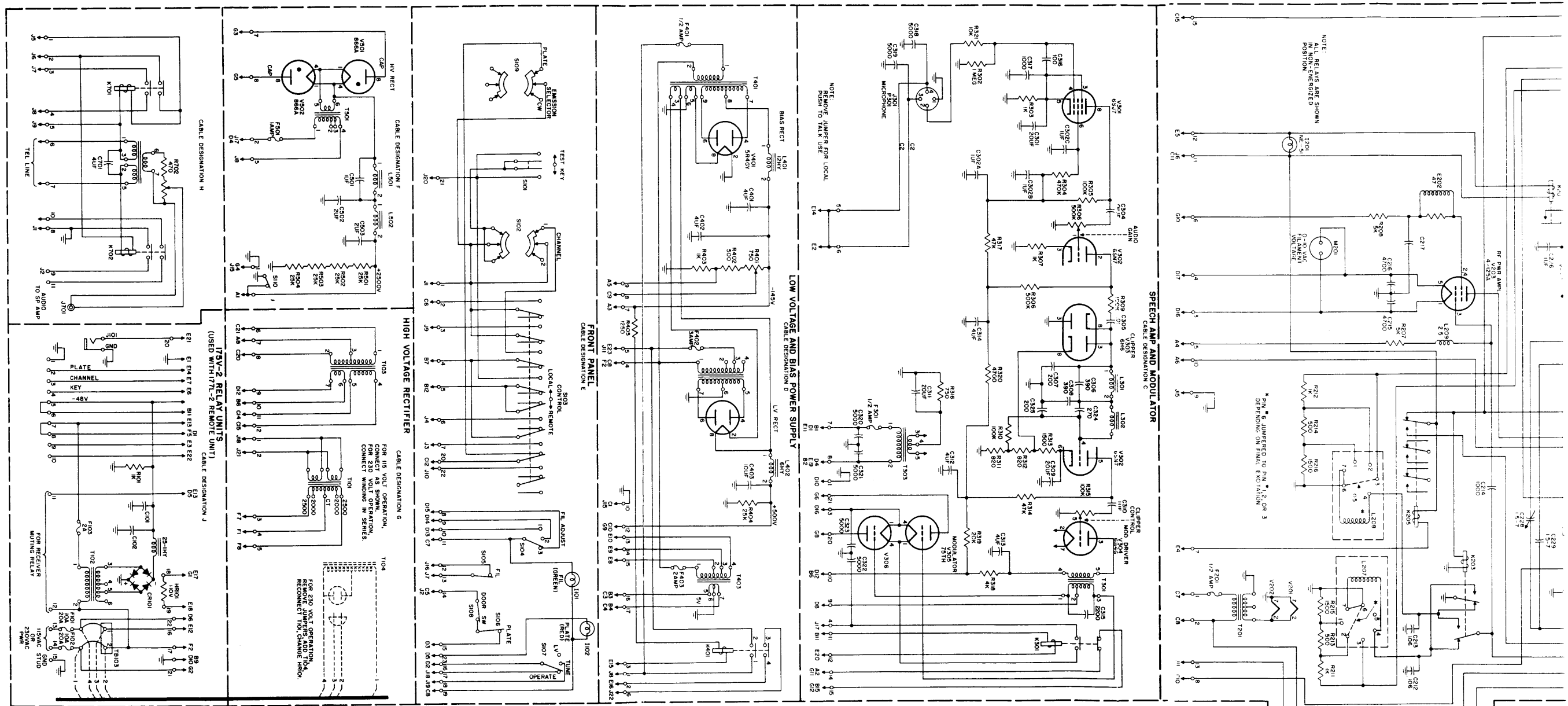

Figure 5-16. T₁

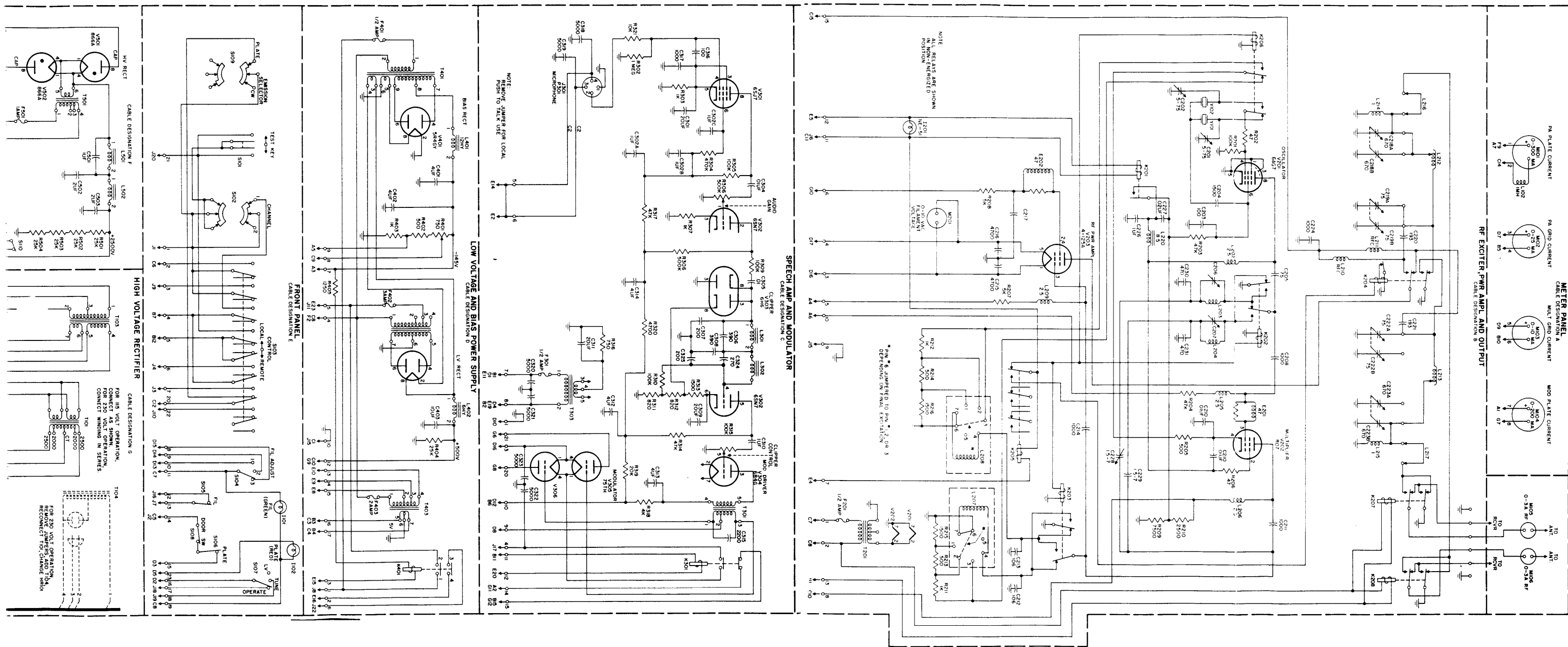

Figure 5-16. Type 30K-5 Transmitter Cabling Schematic, Wired for 115-V Operation

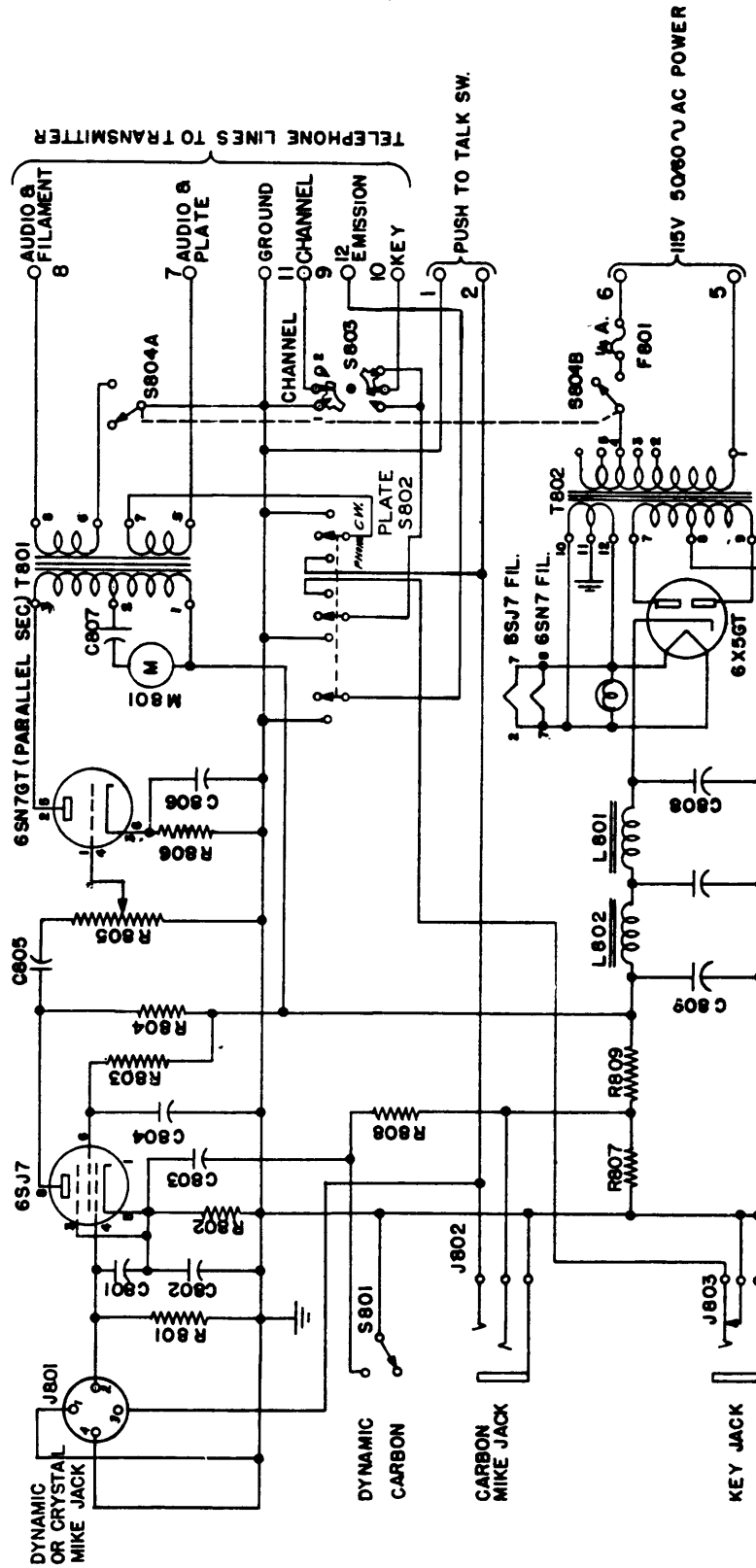

Figure 5-17. Type 177L-2 Remote Control Schematic

SECTION 6 PARTS LIST

30K-5

ITEM	CIRCUIT FUNCTION	DESCRIPTION	COLLINS PART NUMBER
C101	Relay supply voltage filter	CAPACITOR: 20 mf, 500 vdcw	184 6509 00
C102	Relay supply voltage filter	CAPACITOR: 20 mf, 500 vdcw	184 6509 00
C201	Oscillator, V201, grid circuit capacitor	CAPACITOR: variable, mica, 15 to 75 mmf p/m 10%, 500 vdcw	922 3800 00
C202	Oscillator, V201, grid circuit capacitor	CAPACITOR: variable, mica, 15 to 75 mmf p/m 10%, 500 vdcw	922 3800 00
C203	Oscillator, V201, screen capacitor	CAPACITOR: 100 mmf p/m 5%, 500 vdcw	912 0494 00
C204	Oscillator, V201, screen feedback capacitor	CAPACITOR: 1500 mmf p/m 10%, 500 vdcw	935 4060 00
C205	RF coupling capacitor	CAPACITOR: 1000 mmf p/m 20%, 500 vdcw	935 4101 00
C206	Oscillator, V201, plate tank capacitor	CAPACITOR: variable, 10 to 100 mmf	920 1120 00
C207	Oscillator, V201, plate tank capacitor	CAPACITOR: variable, 10 to 100 mmf	920 1120 00
C208	RF coupling capacitor	CAPACITOR: 1000 mmf p/m 20%, 500 vdcw	935 4101 00
C209	Multiplier, V202, screen bypass	CAPACITOR: 10,000 mmf p/m 20% 300 vdcw	935 2118 00
C210	Multiplier, V202, cathode bypass	CAPACITOR: 10,000 mmf p/m 20%, 300 vdcw	935 2118 00
C211	RF coupling capacitor	CAPACITOR: 1000 mmf p/m 20%, 500 vdcw	935 4101 00
C212	Multiplier plate tank capacitor	CAPACITOR: variable, 10 to 100 mmf	920 1120 00

30K-5

ITEM	CIRCUIT FUNCTION	DESCRIPTION	COLLINS PART NUMBER
C213	Multiplier plate tank capacitor	CAPACITOR: variable, 10 to 100 mmf	920 1120 00
C214	RF coupling capacitor	CAPACITOR: fixed, 1000 mmf p/m 20%, 500 vdcw	935 4101 00
C215	RF amplifier, V203 filament bypass capacitor	CAPACITOR: 4700 ohm p/m 20%, 2500 vdcw	936 1105 00
C216	RF amplifier, V203 filament bypass capacitor	CAPACITOR: 4700 ohm p/m 20%, 2500 vdcw	936 1105 00
C217	RF amplifier, V203 screen bypass capacitor	CAPACITOR: 1000 mmf p/m 20%, 2500 vdcw	936 0250 00
C218	Channel 1 antenna tuning and loading capacitor	CAPACITOR: variable, dual sect 670 mmf per sect	920 0018 00
C219	Channel 1 plate tuning capacitor	CAPACITOR: variable, dual sect 75 mmf per sect	920 0016 00
C220	R-f coupling capacitor	CAPACITOR: variable, 193 mmf approx	924 1005 00
C221	R-f coupling capacitor	CAPACITOR: variable, 193 mmf approx	924 1005 00
C222	Channel 2 plate tuning capacitor	CAPACITOR: variable, dual sect 75 mmf per sect	920 0016 00
C223	Channel 2 antenna tuning and loading capacitor	CAPACITOR: variable, dual sect 670 mmf per sect	920 0018 00
C224	R-f coupling capacitor	CAPACITOR: 1000 mmf p/m 5% 5000 vdc peak	938 2066 00
C225		Not used	
C226	Click filter	CAPACITOR: 0.1 mf plus 40%, minus 15%, 600 vdcw	961 5116 00
C227	Click filter	CAPACITOR: 0.02 mf	936 1149 00
C228	Neutralizing capacitor	CAPACITOR: variable, 1.5 to 7 mmf	917 1013 00

30K-5

ITEM	CIRCUIT FUNCTION	DESCRIPTION	COLLINS PART NUMBER
C229	Neutralizing capacitor	CAPACITOR: variable, 1.5 to 7 mmf	917 1013 00
C230	Grid bypass capacitor	CAPACITOR: 470 mmf p/m 5%, 500 vdcw	912 0543 00
C231	Grid bypass capacitor	CAPACITOR: 470 mmf p/m 5%, 500 vdcw	912 0543 00
C301	Audio amplifier V301, cathode bypass	CAPACITOR: 20 mmf plus 100%, minus 10%, 100 vdcw	183 3310 00
C302	C302A, C302B, C302C	CAPACITOR: 3 sect, 0.1 per sect plus 40%, minus 15%, 600 vdcw	961 4059 00
C302A	Plate decoupling capacitor	CAPACITOR: part of C-302	
C302B	Plate decoupling capacitor	CAPACITOR: part of C-302	
C302C	Screen decoupling capacitor	CAPACITOR: part of C-302	
C304	Audio decoupling capacitor	CAPACITOR: mica, 10,000 mmf p/m 20%, 300 vdcw	935 2118 00
C305	Audio decoupling capacitor	CAPACITOR: mica, 10,000 ohm p/m 20%, 300 vdcw	935 2118 00
C306	Audio filter	CAPACITOR: 390 mmf p/m 10%, 500 vdcw	935 0131 00
C307	Audio filter	CAPACITOR: 200 mf p/m 5%, 500 vdcw	935 0118 00
C308	Audio filter	CAPACITOR: 390 mmf p/m 10%, 500 vdcw	935 0131 00
C309	Audio amplifier V302, cathode bypass	CAPACITOR: 20 mf plus 100%, minus 10%, 500 vdcw	183 3310 00 alt 184 6509 00
C310	Audio coupling capacitor	CAPACITOR: 0.1 mf plus 40%, minus 15%, 600 vdcw	961 5116 00 alt 961 5059 00

30K-5

ITEM	CIRCUIT FUNCTION	DESCRIPTION	COLLINS PART NUMBER
C311	Mod driver grid return bypass	CAPACITOR: 20 mf plus 100%, minus 10%, 100 vdcw	183 3310 00 alt 183 6509 00
C312	Audio decoupling capacitor	CAPACITOR: 4 mf p/m 10%, 600 vdcw	961 3005 00
C313	Mod driver plate decoupling capacitor	CAPACITOR: 4 mf p/m 10%, 600 vdcw	961 3005 00
C314	Audio decoupling capacitor	CAPACITOR: 4 mf p/m 10%, 600 vdcw	961 3005 00
C315	Mod grid bypass capacitor	CAPACITOR: 1000 mmf p/m 20%, 500 vdcw	935 4101 00
C316	Audio amplifier V301, RF bypass capacitor	CAPACITOR: 100 mmf p/m 20%, 500 vdcw	935 0107 00
C317	Audio amplifier V301, cathode bypass	CAPACITOR: 1000 mmf p/m 20%, 500 vdcw	935 4101 00
C318	Microphone RF by- pass capacitor	CAPACITOR: 5000 mmf minus 0%, 500 vdcw	913 1187 00
C319	Microphone RF by- pass capacitor	CAPACITOR: 5000 mmf minus 0%, 500 vdcw	913 1187 00
C320	RF bypass T303 pri	CAPACITOR: 5000 mmf minus 0%, 500 vdcw	913 1187 00
C321	RF bypass T303 pri	CAPACITOR: 5000 mmf minus 0%, 500 vdcw	913 1187 00
C322	RF bypass Mod Fil	CAPACITOR: 5000 mmf minus 0%, 500 vdcw	913 1187 00
C323	RF bypass Mod Fil	CAPACITOR: 5000 mmf minus 0%, 500 vdcw	913 1187 00
C324	Audio filter	CAPACITOR: 200 mmf p/m 5%, 500 vdcw	935 0118 00
C325	Audio filter	CAPACITOR: 200 mmf p/m 5%, 500 vdcw	935 0118 00

30K-5

ITEM	CIRCUIT FUNCTION	DESCRIPTION	COLLINS PART NUMBER
C401	Bias voltage supply	CAPACITOR: 4 mf plus 40%, minus 15%, 600 vdcw	961 3005 00
C402	Bias voltage supply	CAPACITOR: 4 mf plus 40%, minus 15%, 600 vdcw	961 3005 00
C403	LV power supply filter	CAPACITOR: 10 mf p/m 10%, 1000 vdcw	930 0038 00
C501	HV power supply filter	CAPACITOR: 1 mf p/m 10%, 5000 vdcw	930 0042 00 alt *930 0035 00
C502	HV power supply filter	CAPACITOR: 2 mf p/m 10%, 4000 vdcw	930 0040 00
C503	HV power supply filter	CAPACITOR: 2 mf p/m 10%, 4000 vdcw	930 0040 00
CR101	Relay voltage supply rectifier	RECTIFIER: selenium, input 72 v AC max	353 0007 00
E201	Control grid suppressor	PARASITIC SUPPRESSOR: 5 turns #18 bus wire 47 ohm 2 watt resistor	505 2262 00
E202	Screen grid suppressor	PARASITIC SUPPRESSOR: 5 turns #18 bus wire on 47 ohm 2 w resistor	505 2262 00
F101	Supply line fuse	FUSE: plug, 20 amp, 125 v (for use w/220 v)	264 0168 00
F101		FUSE: plug; 10 amp, 125 v (for use w/230 v)	264 0171 00
F102	Supply line fuse	FUSE: plug, 20 amp, 125 v (for use w/220 v)	264 0168 00
F102		FUSE: plug; 10 amp, 125 v (for use w/230 v)	264 0171 00
F103	Relay voltage supply fuse	FUSE: cartridge, 2 amp, 250 v	264 4070 00
F201	Exciter filament fuse	FUSE: slow blow, cartridge, 1/2 amp, 250 v	264 4260 00
F301	Mod driver filament fuse	FUSE: slow blow, cartridge, 1/2 amp, 250 v	264 4260 00

* For equipments using 50 cps power source

30K-5

ITEM	CIRCUIT FUNCTION	DESCRIPTION	COLLINS PART NUMBER
F401	Bias voltage supply fuse	FUSE: slow blow; cartridge, 1/2 amp, 250 v	264 4260 00
F402	LV supply fuse	FUSE: cartridge, 3 amp, 250 v	264 4080 00
F403	Modulator and RF amplifier filament fuse	FUSE: cartridge, 2 amp, 250 v	264 4070 00
F501	HV rectifier fuse	FUSE: slow blow; cartridge, 1 amp, 250 v	264 4280 00
HR101	Plate transformer series resistor for tuning	HEATER: 660 w, 115 v (for use w/220 v)	711 0003 00
HR101		HEATER: 600 w, 220 v (for use w/230 v)	711 0093 00
I101	Filament power indicator	LAMP: 125 v, 0.040 amp, 6 w	262 3320 00
I102	Plate power indicator	LAMP: 125 v, 0.040 amp, 6 w	262 3320 00
I103	Light indicator	JEWEL: pilot light, green	262 0258 00
I104	Light indicator	JEWEL: pilot light, red	262 0259 00
I201	Transient suppressor	LAMP: neon, 1/25 w	262 0021 00
J101	Key jack	JACK: phone, midget, 1 ckt	358 1040 00
J301	Microphone or audio connector	CONNECTOR: wall mtg; 4 cont	369 9000 00
K201	Keying control relay	RELAY: armature, 12-48 v, 12 to 24 ma operate .013 sec @ 24 v .007 sec @ 48 v	408 7000 00
K202	Exciter channel selector relay	RELAY: armature, DPDT, 48 v coil	407 1005 00
K203	Exciter channel selector relay	RELAY: armature, DPDT, 48 v coil	407 1005 00
K204	RF power amplifier channel selector	RELAY: rotary, 2 pos, 30° wafer sw driving 48 v DC coil	410 0020 00

30K-5

ITEM	CIRCUIT FUNCTION	DESCRIPTION	COLLINS PART NUMBER
K205	Output network channel selector	RELAY: armature, DPDT cont w/ SPDT aux, 48 v coil	407 1006 00
K206		RELAY: armature, DPDT 48 v DC nominal, coil resistance 1000 ohm	407 1005 00
K207	Antenna transfer	RELAY: armature, DPDT 48 v coils	407 1000 00
K208	Antenna transfer	RELAY: armature, 5 amp 115 v coil, 540 ohm resistance	407 1000 00
K301	Phone-CW selector relay	RELAY: armature, DPDT; 48 v DC coil	407 1056 00
K401	Plate power relay	RELAY: armature, SPNO double break, 15 amp cont, 112 v DC coil	405 1055 00
L101	Relay supply volt- age filter	REACTOR: filter, 0.25-1 HV 1 hy @ 0.050 amp, 0.25 hy @ 0.4 amp, 5 ohm max, 120 cps, 1000 TV, RMS	678 0154 00
L102	Meter RF filter	CHOKE: RF, multiple pie, duo- lateral wnd 1 mh p/m 10% 600 ma, 6 ohm DC	240 0055 00
L202	V201 plate tuning choke	COIL: RF choke, 4 pie, duolat- eral wnd, 2.5 mh, 0.125 amp, 50 ohm	240 5300 00
L203, L204	Oscillator plate tank inductor	COIL: RF choke, 4 pie, duolat- eral wnd, 2.5 mh, 0.125 amp, 50 ohm max	*503 3830 003
		COIL: 21 turns #24 bus wire, 4.5 to 6.0 mc, shielded can	*503 3831 003
		COIL: 14 turns #24 bus wire, 6.0 to 8.0 mc, shielded can	*503 3832 003
		COIL: 9-1/2 turns #24 bus wire, 8.0 to 10.5 mc, shielded can	*503 3833 003
L205	V202 multiplier grid choke	COIL: RF choke, 4 pie, duolat- eral wnd, 2.5 mh, 0.125 amp, 50 ohm	240 5300 00

* Choose coils for frequency desired (see coil chart in installation section).

30K-5

ITEM	CIRCUIT FUNCTION	DESCRIPTION	COLLINS PART NUMBER
L206	V202 multiplier plate supply choke	COIL: RF choke, 4 pie, duolateral wnd, 2.5 mh, 0.125 amp, 50 ohm	240 5300 00
L207, L208	Multiplier plate tank indicator	COIL: 54 turns #24 DSC, 2.0-2.6 mc, shielded can	*503 3828 003
		COIL: 36 turns #24 DSC, 2.6-3.4 mc	*503 3829 003
		COIL: 34 turns #24 bus wire, 3.4-4.5 mc, shielded can	*503 3830 003
		COIL: 21 turns #24 bus wire, 4.5-6 mc, shielded can	*503 3831 003
		COIL: 14 turns #24 bus wire, 6.0 to 8.0 mc, shielded can	*503 3832 003
		COIL: 9-1/2 turns #24 bus wire, 8.0 to 10.5 mc, shielded can	*503 3833 003
		COIL: 8 turns #24 bus wire, 10.5 to 14.0 mc, shielded can	*503 3834 003
		COIL: 5 turns #24 bus wire, 14 to 18 mc, shielded can	*503 3835 003
		COIL: 5 turns #16 bus wire, 18 to 24 mc, shielded can	*503 3836 003
		COIL: 5 turns #16 bus wire, 24 to 30 mc, shielded can	*503 3837 003
L209	V203, RF power amplifier grid choke	COIL: RF choke, 4 pie, duolateral wnd, 2.5 mh, 0.125 amp, 50 ohm max	240 5300 00
L210, L211	V203, RF power amplifier plate supply choke	COIL: RF choke, 2-10.5 mc, 300 uh	*503 3821 002
L212, L213	RF power amplifier output tank inductor	COIL: 46 turns #14 bus wire	*503 3838 003
		COIL: tank, 24 turns, #12 bus wire	*503 3839 003
		COIL: tank, 12 turns #12 bus wire	*503 3840 003

* Choose coils for frequency desired (see coil chart in installation section).

30K-5

ITEM	CIRCUIT FUNCTION	DESCRIPTION	COLLINS PART NUMBER
		COIL: tank, 8 turns #10 bus wire	*503 3841 003
		COIL: tank, 6 turns 1/2" wd copper ribbon	*503 3842 003
L214, L215	Static drain choke	COIL: RF, multiple pie, duolateral wnd, 1 mh, p/m 10% 600 ma, 6 ohm	240 0055 00
L216, L217	Low frequency load inductor	COIL: load, 46 turns #14 bus wire	**503 3843 003
L301	Audio filter reactor	REACTOR: audio, 3.75 hy, 1000 RMS, TV, 100-5000 CPS	678 0077 00
L302	Audio filter	REACTOR: audio, 3.75 hy, 1000 RMS, TV, 100-5000 CPS	678 0077 00
L401	Bias supply filter	REACTOR: filter, 12 hy, 75 ma, 2500 RMS TV, 120 cps, 275 ohm	678 0075 00
L402	LV power supply filter	REACTOR: filter, 6 hy, 250 ma, 2500 RMS TV, 120 cps, 62 ohm	678 0076 00
L501	HV power supply filter	REACTOR: filter, 12 hy, 300 ma, 10,000 RMS TV, resonates at 120 cps w/ 0.1 mf capacitor and 30 ma DC load	678 0081 00
L502	HV power supply filter	REACTOR: filter, 12 hy, 300 ma, 10,000 RMS TV, resonates at 120 cps w/ 0.1 mf capacitor and 30 ma DC load	678 0081 00
M101	Power amplifier plate current meter	METER: 0-300 ma DC, 30 scale div, 10 ma per div	450 0031 00
M102	Power amplifier grid current meter	METER: 0-25 ma DC, 2% accuracy	450 0029 00
M103	Multiplier grid current meter	METER: 0-10 ma DC, 50 scale div, 0.2 ma per div	450 0049 00
M104	Modulator plate current meter	METER: 0-200 ma DC, 40 scale div, 5 ma per div	450 0030 00

* Choose coils for frequency desired (see coil chart in installation section).
 ** For low frequency operation.

30K-5

ITEM	CIRCUIT FUNCTION	DESCRIPTION	COLLINS PART NUMBER
M105	Antenna current meter	METER: 0-3 amp, RF, 30 scale div, 0.1 amp per div, int thermocouple	451 0018 00
M106	Antenna current meter	METER: 0-3 amp RF, 30 scale div, 0.1 amp per div, int thermocouple	451 0018 00
M201	Filament voltage meter	METER: 0-10 v, AC, 2% accuracy	452 0006 00
P301	Microphone connector	CONNECTOR: cable, 4 cont	369 8100 00
R101	Relay voltage supply bleeder resistor	RESISTOR: 1000 ohm, p/m 10%, 10 w	710 1142 00
R201	Oscillator: V201, grid resistor	RESISTOR: 100,000 ohm p/m 10%, 1 w	745 3170 00
R202	Oscillator: V201, grid resistor	RESISTOR: 47 ohm p/m 10%, 1 w	745 3030 00
R203	Oscillator: V201, screen resistor	RESISTOR: 47,000 ohm, 2 w	745 9167 00
R204	Multiplier: V201, grid resistor	RESISTOR: 47,000 ohm, 2 w	745 9167 00
R205	Multiplier: V202, cathode resistor	RESISTOR: 500 ohm p/m 10%, 10 w	710 1500 20
R206	V202, screen voltage dropping resistor	RESISTOR: 47 ohm p/m 10%, 1 w	745 3030 00
R207	RF power amp V203 grid resistor	RESISTOR: 5000 ohm p/m 10%, 25 w	710 3542 00
R208	RF power amp V203 screen dropping resistor	RESISTOR: 5000 ohm p/m 10%, 50 w	710 4542 00
R209	Exciter screen voltage divider resistor	RESISTOR: 7500 ohm p/m 10%, 25 w	710 0069 00

30K-5

ITEM	CIRCUIT FUNCTION	DESCRIPTION	COLLINS PART NUMBER
R210	Exciter screen voltage divider resistor	RESISTOR: 2500 ohm p/m 10%, 25 w	710 0066 00
R211	PA drive control	RESISTOR: 1000 ohm p/m 10%, 10 w	710 1142 00
R212	PA drive control	RESISTOR: 1000 ohm p/m 10%, 10 w	710 1142 00
R213	PA drive control	RESISTOR: 500 ohm p/m 10%, 10 w	710 1500 20
R214	PA drive control	RESISTOR: 500 ohm p/m 10%, 10 w	710 1500 20
R215	PA drive control	RESISTOR: 1500 ohm p/m 10%, 10 w	710 0027 00
R216	PA drive control	RESISTOR: 1500 ohm p/m 10%, 10 w	710 0027 00
R217	Multiplier grid suppressor	RESISTOR: 47 ohm p/m 10%, 1 w	745 3030 00
R302	Audio amplifier, V301, grid re- sistor	RESISTOR: 1.0 megohm, p/m 10%, 1/2 w	745 1212 00
R303	Audio amplifier, V301, cathode resistor	RESISTOR: 1000 ohm p/m 10%, 1/2 w	745 1086 00
R304	Audio amp, V301, screen resistor	RESISTOR: 470,000 ohm p/m 10%, 1/2 w	745 1198 00
R305	Audio amp, V301, cathode resistor	RESISTOR: 0.10 megohm p/m 10%, 1/2 w	745 3170 00
R306	Audio gain control	RESISTOR: variable, comp, 500,000 ohm, 1/2 w, 350 V max	376 3027 00
R307	Audio amp, V302, cathode resistor	RESISTOR: 1000 ohm p/m 10%, 1 w	745 3086 00
R308	Audio amp, V302, plate resistor	RESISTOR: 47,000 ohm p/m 10%, 2 w	745 9167 00
R309	Audio equalizing resistor	RESISTOR: 0.10 megohm p/m 10%, 1/2 w	745 1170 00

30K-5

ITEM	CIRCUIT FUNCTION	DESCRIPTION	COLLINS PART NUMBER
R310	Audio amp, V302, grid resistor	RESISTOR: 0.10 megohm p/m 10%, 1 w	745 3170 00
R311	Audio amp, V302, cathode divider	RESISTOR: 820 ohm p/m 5%, 1/2 w	745 3082 00
R312	Audio amp, V302, cathode voltage divider	RESISTOR: 820 ohm p/m 5%, 1/2 w	745 3082 00
R313	Audio amp, V302, cathode voltage divider	RESISTOR: 1500 ohm p/m 5%, 1 w	745 3092 00
R314	Audio amp, V302, plate resistor	RESISTOR: 47,000 ohm p/m 10%, 2 w	745 9167 00
R315	Peak clipping control	RESISTOR: variable, 0 to 100,000 ohm, 1 w	376 0021 00
R316	Mod driver, V304, bias resistor	RESISTOR: 750 ohm p/m 10%	710 1750 20
R317	Audio input amp V301, decoupling resistor	RESISTOR: 47,000 ohm p/m 10%, 1 w	745 3156 00
R318	Mod driver de-coupling resistor	RESISTOR: 4000 ohm p/m 10%, 50 w	710 4442 00
R319	Plate decoupling resistor	RESISTOR: fixed, 20,000 ohm p/m 10%, 10 w	710 1204 20
R320	Plate decoupling resistor	RESISTOR: fixed, 4700 ohm p/m 10%, 2 w	745 9125 00
R321	RF decoupling resistor	RESISTOR: fixed, 10,000 ohm p/m 10%, 1/2 w	745 1128 00
R401	Mod bias control	RESISTOR: variable, 750 ohm p/m 10%, 25 w	735 0002 00
R402	Bias supply voltage divider	RESISTOR: 500 ohm p/m 10%, 10 w	710 1500 20
R403	Bias supply voltage divider	RESISTOR: fixed, 1000 ohm p/m 10 w	710 1142 00
R404	LV power supply bleeder resistor	RESISTOR: 25,000 ohm p/m 10%, 50 w	710 4254 20

30K-5

ITEM	CIRCUIT FUNCTION	DESCRIPTION	COLLINS PART NUMBER
R405	Voltage drop relay	RESISTOR: 1,250 ohm 10%, 10 w	710 0024 00
R501	HV power supply bleeder resistor	RESISTOR: 25,000 ohm p/m 10%, 50 w	710 4254 20
R502	HV power supply bleeder resistor	RESISTOR: 25,000 ohm p/m 10%, 50 w	710 4254 20
R503	HV power supply bleeder resistor	RESISTOR: fixed, 25,000 ohm p/m 10%, 50 w	710 4254 20
R504	HV power supply bleeder resistor	RESISTOR: 25,000 ohm p/m 10%, 50 w	710 4254 20
S101	Test key switch	SWITCH: lever, contact 1A 1A and 1A 1A, 100 V 60 cyc AC non-ind	375 0049 00
S102	Channel selector sw	SWITCH: rotary, 2 cont 2 pos	259 0239 00
S103	Local-Remote control switch	SWITCH: lever, cont	375 0025 00
S104	Filament voltage control switch	SWITCH: rotary; 1 ckt, 3 pos	259 1180 00
S105	Filament power ON- OFF switch	SWITCH: toggle, SPST	266 3005 00 alt 266 1040 00
S106	Plate power ON-OFF switch	SWITCH: toggle, SPST	266 3005 00 alt 266 1040 00
S107	Plate voltage control switch	SWITCH: rotary; ckt, 30 pos	259 1180 00
S108	HV interlock	SWITCH: push, SPST N.O.	266 0003 00 alt 266 0001 00
S109	Emission selector	SWITCH: rotary, 2 ckt, 2 pos	259 0239 00
S110	HV shorting	BAR: interlocking SPRING: tension	504 1294 002 340 2180 00
T101	HV power supply plate transformer	TRANSFORMER: power plate pri #1 115 V 50/60 cps, pri #2 115 V 50/60 cps secd #1 and #2 2365/2950 V	662 0015 00 alt 662 0127 00

30K-5

ITEM	CIRCUIT FUNCTION	DESCRIPTION	COLLINS PART NUMBER
T102	Relay voltage supply transformer	TRANSFORMER: power, pri 115 V 50/60 cps secd 72/67/62 V, 0.58 amp	674 0153 00
T103	Modulation transformer	TRANSFORMER: audio modulator, pri 32,000 ohm CT secd #1 16,000 ohm secd #2 248 V RMS	677 0316 00
T104		TRANSFORMER: auto, input 220-250 V, 2.1 amp; output 110-125, 4.3 amp; 50/60 cps (for use w/230 V)	662 0165 00
T201	Exciter filament transformer	TRANSFORMER: power, 115 V pri 50/60 cps, secd 6.3 V CT, 3 amp	672 0069 00
T301	Modulator driver transformer	TRANSFORMER: audio driver pri, 2500 ohm, 60 ma bal; sec 15,000 ohm CT 100-5000 cps p/m 1-1/2 db	677 0074 00
T303	Modulator driver filament transformer	TRANSFORMER: power, pri 115 V, 50/60 cps 6.3 V CT, 3 amp	672 0069 00
T401	Basic voltage supply transformer	TRANSFORMER: power, pri 115 V, 50/60 cps, secd #1 5 V 2 amp, secd #2 5 V; 2 amp, secd #3 420 V CT, 1 amp 2500 TV, 62 VA	672 0068 00
T402	LV power supply transformer	TRANSFORMER: power, pri 105/115/125 V 50/60 cps, secd 1320 V CT 0.177 amp 2500 TV, 233 VA	672 0080 00
T403	Modulator and RF power amp filament transformer	TRANSFORMER: power, pri 105/110/115 V 50/60 cps 5 V CT, 20 amp	672 0072 00
T501	HV rectifier filament transformer	TRANSFORMER: power, pri 105/110/115 V 50/60 cps, secd 2.5 V, 10 amp	672 0079 00
V201	Oscillator	TUBE: electron 6 V6GT/G beam power amp	255 0039 00
V202	Multiplier	TUBE: electron 807, power tetrode	265 0033 00
V203	RF power amplifier	TUBE: electron, 4-125A, power triode	256 0086 00
V301	Audio amplifier	TUBE: electron, 6SJ7 triple grid detector amplifier	255 0030 00

30K-5

ITEM	CIRCUIT FUNCTION	DESCRIPTION	COLLINS PART NUMBER
V302	Audio amplifier	TUBE: electron, 6SNGT, twin triode amp	255 0033 00
V303	Audio peak clipper	TUBE: electron, 6H6, twin diode	255 0117 00
V304	Modulator driver	TUBE: electron, 6B4G power amplifier triode	255 0124 00
V305	Modulator	TUBE: electron, 75 TH medium mutriode	256 0071 00
V306	Modulator	TUBE: electron, 75 TH medium mutriode	256 0071 00
V401	Bias supply rectifier	TUBE: electron, 5R4GY full wave high vacuum rectifier	257 0020 00
V402	LV supply rectifier	TUBE: electron, 5R4GY full wave high vacuum rectifier	257 0020 00
V501	HV supply rectifier	TUBE: electron, 866A half wave mercury vapor rectifier	256 0049 00
V502	HV supply rectifier	TUBE: electron, 866A half wave mercury, vapor rectifier	256 0049 00
XF101	Socket for F101	HOLDER: fuse (includes XF102)	265 1013 00
XF103	Holder for F103	HOLDER: fuse, fuse cartridge 1/2" -24 thd mtg bushing 11/16" dia x 2-7/16" lg o/a lug terms	265 1002 00
XF201	Holder for F201	HOLDER: fuse, cartridge, 1/2" -24 thd mtg bushing	265 1002 00
XF301	Holder for F301	HOLDER: fuse, cartridge, 1/2" -24 thd mtg bushing	265 1002 00
XF401	Holder for F401	HOLDER: fuse, fuse cartridge, 1/2" -24 thd mtg bushing	265 1002 00
XF402	Holder for F402	HOLDER: fuse, fuse cartridge, 1/2" thd mtg bushing	265 1002 00
XF403	Holder for F403	HOLDER: fuse, fuse cartridge, 1/2" -24 thd mtg bushing	265 1002 00
XF501	Holder for F501	HOLDER: fuse, fuse cartridge, 1/2" -24 thd mtg bushing	265 1002 00

30K-5

ITEM	CIRCUIT FUNCTION	DESCRIPTION	COLLINS PART NUMBER
XHR101	Socket for HR101	SOCKET: screw type 115 V. 660 w porcelain	265 1010 00
XI101	Socket for I101	HOLDER: pilot light mtg, 1" -27 thd bushing	262 0255 00
XI102	Socket for I102		
XI201	Socket for I201	HOLDER: lamp, min bayonet	262 1260 00
XL203	Socket for L203	SOCKET: med 7 cont w/ clips	220 5730 00
XL204	Socket for L204	SOCKET: med 7 cont w/ clips	220 5730 00
XL207	Socket for L207	SOCKET: med 7 cont w/ clips	220 5730 00
XL208	Socket for L208	SOCKET: med 7 cont w/ clips	220 5730 00
XL210	Socket for L210	JACK: post, 1-9/16" h ceramic post w/ banana jack	190 1132 00
XL211	Socket for L211		
XL212	Socket for L212	JACK ASSEMBLY: plate 1/4" thk mycalex	503 3046 002
XL213	Socket for L213		
XV201	Socket for XV201	SOCKET: tube, std octal	220 1005 00
XV202	Socket for XV202	SOCKET: tube, 5 prong w/ clips	220 5520 00
XV203	Socket for XV203	SOCKET: tube, 5 prong w/ clips	220 1016 00
XV301	Socket for V301	SOCKET: tube, std octal	220 1005 00
XV302	Socket for V302	SOCKET: tube, std octal	220 1005 00
XV303	Socket for V303	SOCKET: tube, std octal	220 1005 00
XV304	Socket for V304	SOCKET: tube, std octal	220 1005 00
XV305	Socket for V305	SOCKET: tube, 4 prong w/ clips	220 5450 00
XV306	Socket for V306	SOCKET: tube, 4 prong w/ clips	220 5450 00
XV401	Socket for V401	SOCKET: tube, std octal	220 1005 00
XV402	Socket for V402	SOCKET: tube, std octal	220 1005 00
XV501	Socket for V501	SOCKET: tube, 4 prong w/ clips	220 5450 00
XV502	Socket for V502	SOCKET: tube, 4 prong w/ clips	220 5450 00
XY201	Socket for type HC-6/U crystal	SOCKET: crystal holder	292 0059 00

30K-5

ITEM	CIRCUIT FUNCTION	DESCRIPTION	COLLINS PART NUMBER
XY202	Socket for type HC-6/U crystal	SOCKET: crystal holder	292 0059 00
<u>175V-2 Relay Unit</u>			
C701	Remote line capacitor	CAPACITOR: 4 mf plus 40% minus 15%, 600 vdcw	961 3005 00
J701	Audio connector	CONNECTOR: chassis mtg, 3 ckt midget	369 1008 00
K701	Auxiliary filament power control	RELAY: armature, DPST, NO, 50 V, coil	407 1004 00
K702	Auxiliary plate power control	RELAY: armature, DPST, NO, 50 V, coil	407 1004 00
P701	Audio connector	CONNECTOR: plug, for shielded cable up to 1/4" OD max	369 1006 00
R701	Audio input level adjustment	RESISTOR: variable, 100 ohm	377 0036 00
R702	Audio pad	RESISTOR: 470 ohm p/m 10%, 1 w	145 3072 00
T701	Control lines transformer	TRANSFORMER: audio, pri, 600 ohm, 100-4000 cps p/m 1 db	677 0156 00
<u>177L-2 Remote Control Unit</u>			
C801	Audio amplifier, V801, grid cap	CAPACITOR: 100 mmf p/m 20%, 500 vdcw	935 0107 00
C802	Audio amplifier, V801, cathode bypass	CAPACITOR: 1000 mmf p/m 20%, 500 vdcw	935 4101 00
C803	Audio amplifier, V801, cathode bypass	CAPACITOR: 4mf plus 40% minus 15% 600 vdcw	961 3005 00
C804	Audio amplifier, V801 screen bypass	CAPACITOR: 600 vdcw	961 4314 00
C805	Audio coupling	CAPACITOR: 0.1 mf plus 40% minus 15%, 600 vdcw	961 4020 00
C806	Audio coupling V802, capacitor	CAPACITOR: 20 mf, 150 vdcw	184 6509 00

30K-5

ITEM	CIRCUIT FUNCTION	DESCRIPTION	COLLINS PART NUMBER
C807	Audio coupling	CAPACITOR: 4 mf plus 40% minus 15%, 600 vdcw	961 3005 00
C808	Plate supply filter	CAPACITOR: 4 mf plus 40% minus 15%, 600 vdcw	961 3005 00
C809	Plate supply filter	CAPACITOR: dual sect, 40 mf per sect plus 100% minus 15%, 450 vdcw	183 1009 00
F801	Power line fuse	FUSE: cartridge, 1/4 amp, 250 V, slow blow	264 4240 00
I801	Indicator lamp	LAMP: pilot bulb, 6.3 V, 15 amp, min bayonet base	262 3240 00
J802	Carbon microphone jack	CONNECTOR: chassis mtg, 3 ckt midget	358 1050 00
J803	Key jack	JACK: closed ckt	360 1060 00
L801	Plate supply filter	REACTOR: filter, 15 hy, 0.02 amp, 120 cps, 2500 TV	678 1181 00
L802	Plate supply filter	REACTOR: filter, 15 hy, 0.02 amp, 120 cps	678 1181 00
M801	Audio level indicator	METER: power level, minus 10 to plus 6 db, 5000 ohm int res at 0 db	455 2500 00
P801	High impedance microphone conn	CONNECTOR: cable, 4 cont	369 8000 00
P802	Carbon microphone connector plug	PLUG: phone, 3 cond	361 0001 00
R801	Audio amplifier, V801, grid resistor	RESISTOR: 1.0 megohm p/m 10%, 1/2 w	745 1212 00
R802	Audio amplifier, V801, cathode resistor	RESISTOR: 2200 ohm p/m 10%, 1/2 w	745 1100 00
R803	Audio amplifier, V801 screen resistor	RESISTOR: 2.2 ohm p/m 10%, 1/2 w	745 1226 00

30K-5

ITEM	CIRCUIT FUNCTION	DESCRIPTION	COLLINS PART NUMBER
R804	Audio amplifier V801 plate resistor	RESISTOR: 0.47 megohm p/m 10%, 1/2 w	745 1198 00
R805	Audio gain control	RESISTOR: variable, comp, 0.50 megohm, 1/2 w, 350 V max	376 3027 00
R806	Audio amplifier V802 cathode resistor	RESISTOR: 470 ohm p/m 10%, 1/2 w	745 1072 00
R807	Plate supply volt- age divider, bleeder resistor	RESISTOR: 2200 ohm p/m 10%, 1/2 w	745 1100 00
R808	Plate supply volt- age divider bleeder resistor	RESISTOR: 4700 ohm p/m 10%, 1/2 w	745 1114 00
R809	Plate supply volt- age divider bleeder resistor	RESISTOR: 33,000 ohm p/m 10%, 2 w	745 5149 00
S801	Dynamic or carbon microphone switch	SWITCH: toggle, DPDT	260 0527 00
S802	Plate power control switch	SWITCH: rotary, thru 3 pos w/ detent and fixed rotation	259 0018 00
S803	Channel selector sw	SWITCH: rotary 2 ckt 2 pos	259 0239 00
S804	ON-OFF switch	SWITCH: toggle, DPDT	260 0527 00
T801	Audio output transformer	TRANSFORMER: audio, pri 600/ 15,000 ohm, secd 600 ohm CT, 100-4000 cps p/m 1 db	677 0159 00
T802	Power transformer	TRANSFORMER: power, plate, and fil, pri 105/110/115 120 V 50/60 cps, secd #1 400 V CT, 0.25 amp, secd #2 6.3 V 2 amp	672 2550 00
V801	Audio amplifier	TUBE: electron 6SU7 triple grid amp	255 0030 00
V802	Audio amplifier	TUBE: electron, 6SN7GT twin diode amp	255 0033 00
V803	Rectifier	TUBE: electron, 6X5GT full wave rectifier	255 0037 00

30K-5

ITEM	CIRCUIT FUNCTION	DESCRIPTION	COLLINS PART NUMBER
XF801	Holder for F801	HOLDER: fuse cartridge 1/2"-24 thd mtg bushing	265 1002 00
XI801	Socket for I801	MTG: pilot light, for miniature bayonet base bulb	262 1260 00
XV801	Socket for V801	SOCKET: tube, std octal	220 1005 00
XV802	Socket for V802		
XV803	Socket for V803		

SECTION 7

APPENDIX 1

ANTENNAS WITH 52-OHM COAXIAL FEED LINES

7.1. GENERAL DISCUSSION.

This section pertains to some antennas which may be used with the 3OK-5 Transmitter.

The advantages of using these antennas are listed below:

- (a) Broadband.
- (b) Coaxial feed system provides shielding for better signal-to-noise ratio at the receiver input terminals.
- (c) The half-wave dipole antennas attenuate spurious radiation.
- (d) No added tuning controls are necessary.
- (e) Coaxial connectors provide a convenient means of transferring antennas.

7.2. ANTENNA DETAILS.

The 3OK-5 Transmitter is designed with unbalanced output to secure the advantages of pi and L networks, notable of which is reduction of harmonic radiation.

The 3OK-5 antenna output circuit is designed to work into an unbalanced resistive load. Hence, the transmission line must incorporate a method of line balancing in order to match between the unbalanced output circuits and a balanced radiator. Figures 7-4 and 7-5 show construction details of horizontal dipoles for use with the 3OK-5. Each dipole is constructed with a balun to match the dipole to a coaxial feed line.

7.3. TRANSMISSION LINE.

At some installations a long transmission line will be necessary. For lowest transmission line losses, a high impedance open wire balanced line is recommended. To secure the advantage of the low losses of an open wire line, it is necessary to use an unbalanced to balanced impedance matching transformer (balun) to transfer from the unbalanced low impedance output termination, provided on the transmitter to a high impedance open wire balanced line. Figure 7-1 indicates the construction details of a balun for this purpose and paragraph 7-5 explains how the circuit values are computed.

7.4. TEST INFORMATION.

All baluns mentioned in this discussion are resonant circuits. The baluns are cut to operate at the center frequency of the band specified.

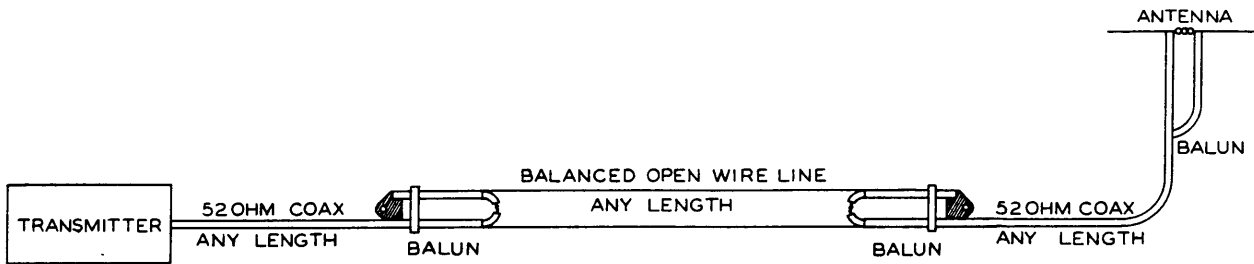

THIS SYSTEM PERMITS USE OF A BALANCED OPEN WIRE LINE TO REDUCE LOSSES ON LONG TRANSMISSION LINES. CONSTRUCTION DETAILS OF THE UNBALANCED TO BALANCED IMPEDANCE MATCHING TRANSFORMER (BALUN) USED BETWEEN THE OPEN WIRE LINE AND THE 52 OHM RG-8/U COAXIAL CABLE ARE SHOWN BELOW.

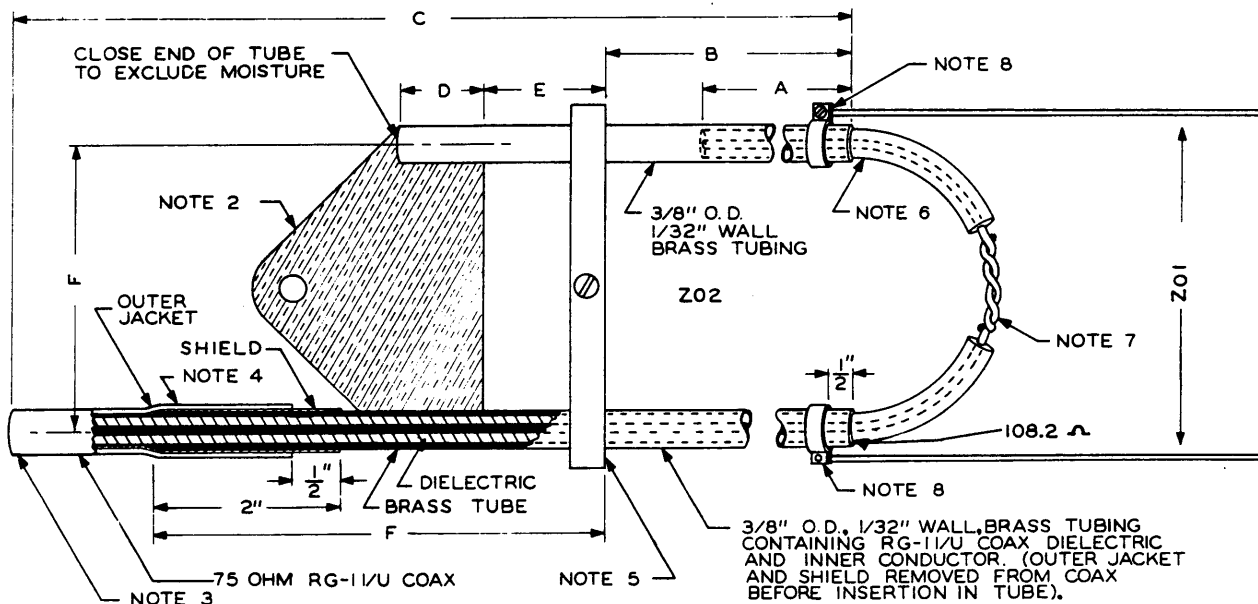

1. DIMENSIONS D, E AND F ARE NOT CRITICAL AND MAY BE ADAPTED TO THE INDIVIDUAL INSTALLATION. DIMENSION D SHOULD BE LONG ENOUGH TO PERMIT SILVER SOLDERING BRASS PLATE AND TUBES TOGETHER. DIMENSION E SHOULD BE LONG ENOUGH TO PERMIT ADJUSTMENT OF THE SHORTING BAR. DIMENSION F SHOULD BE LONG ENOUGH TO PROVIDE SUFFICIENT OVERHANG FOR CONNECTING THE RG-11/U CABLE. EXAMPLES OF HOW TO SOLVE FOR LENGTHS A, B AND C ARE GIVEN ON THE NEXT FEW PAGES.
2. BRASS PLATE OF CONVENIENT SIZE SILVER SOLDERED TO THE TWO BRASS TUBES. PLATE MAY BE GROUNDED OR UNGROUNDED AND IS DESIGNED TO SECURE THE BALUN TO AN END SUPPORT.
3. ATTACH A COAX CONNECTOR HERE TO PERMIT ATTACHING A LENGTH OF 52 OHM RG-8/U COAX.
4. REMOVE OUTER JACKET AND SHIELD FROM A LENGTH OF RG-11/U 75 OHM COAXIAL CABLE. CUT THE OUTER JACKET 1/2 INCH SHORTER THAN THE SHIELD, BEVEL THE OUTER EDGE OF THE 3/8" O.D. BRASS TUBE. SLIDE THE DIELECTRIC INSIDE THE TUBE. FORCE THE BEVELED END OF THE BRASS TUBE BETWEEN THE DIELECTRIC AND THE SHIELD FOR A DISTANCE OF ABOUT 2 INCHES AS SHOWN. SOLDER THE SHIELD TO THE TUBE, USING A MINIMUM AMOUNT OF HEAT TO AVOID DAMAGING THE DIELECTRIC. COVER THE AREA WITH SCOTCH ELECTRICAL TAPE TO EXCLUDE MOISTURE.
5. THIS SHORTING BAR SHOULD BE MOVABLE TO PERMIT ADJUSTING THE BALUN TO REDUCE THE OVERALL STANDING WAVE RATIO OF THE SYSTEM.
6. REMOVE THE OUTER JACKET AND SHIELD FROM A LENGTH OF RG-8/U 52 OHM COAX. INSERT THE PROPER LENGTH OF BARE DIELECTRIC INSIDE THE TUBE.
7. SOLDER INNER CONDUCTORS TOGETHER. COVER THE TUBE ENDS AND ALL OF THE CABLE BETWEEN WITH A CONTINUOUS WRAPPING OF SCOTCH ELECTRICAL TAPE TO EXCLUDE MOISTURE.
8. INSTALL A BRACKET FOR ATTACHING THE OPEN WIRE LINE. IF BRACKET IS SOLDERED, BE VERY CAREFUL TO AVOID OVERHEATING AND DAMAGING THE DIELECTRIC.

Figure 7-1. Balun with Balanced Open Wire Line

If it is desired to check any balun, disconnect the antenna from the balun, and the center conductor of the feed cable from the shield of the opposite cable. Use a grid dip meter, or other means, to check for resonance. If the balun is off frequency, correction may be made by changing the length of the balun. The resonant frequency may also be varied by altering the spacing between cables. The length of the balun must not exceed one quarter wavelength.

7.5. IMPEDANCE TRANSFORMING BALUN FOR OPEN WIRE LINE.

The balun is shown in figure 7-1. Dimension C represents a quarter wavelength of 75 ohm cable (RG-11/U). This transforms the 52-ohm input impedance up to 108.2 ohms.

$$C = \frac{164}{f} \quad (1)$$

where: C = feet

f = frequency in mc

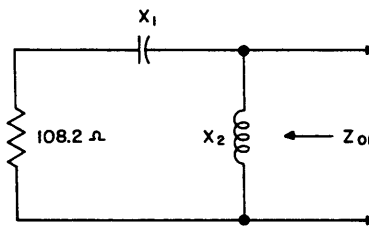

Figure 7-2. Equivalent Circuit, 108.2 ohms to Z_{01}

Figure 7-2 shows the equivalent circuit for the remainder of the transformation from 108.2 ohms to the impedance Z_{01} of the open wire balanced line. X_1 represents the reactance of the stub of length A and X_2 represents the reactance of the stub of length B.

$$X_1 = -\sqrt{108.2 (Z_{01} - 108.2)} \quad (2)$$

$$X_2 = -\frac{11710}{X_1} - X_1 \quad (3)$$

$$\tan \frac{2\pi A}{\lambda_g} = \frac{52}{X_1} \quad (4)$$

Stub A is made of 52 ohm RG-8/U.

$$\frac{2\pi A}{\lambda_g} = 0.04572 \text{ fA electrical degrees of line} \quad (5)$$

where: A = inches

f = frequency in mc

λ_g = wavelength in polyethylene cable (2/3 of freespace wavelength)

$$\tan \frac{2\pi B}{\lambda} = \frac{X_2}{Z_{02}} \quad (6)$$

$$\frac{2\pi B}{\lambda} = 0.366 \text{ rad} \quad (7)$$

where: B = feet

λ = wavelength

Z_{02} is the surge impedance of the stub line composed of the two 3/8 in. OD tubes and is dependent on the ratio of the spacing to the diameter of the conductors. It is mechanically convenient to space these tubes approximately the same as the open wire line. The graph of figure 7-3 may be used to find the surge impedance Z_{01} of the open wire line.

Sample Calculation

Let: $Z_{01} = 523 \text{ ohms}$

$f = 14.15 \text{ mc}$

$F = 3 \text{ inches}$

From equation (1) $C = \frac{164}{14.15} = 11 \text{ ft. } 7 \text{ in.}$

From equation (2) $X_1 = -\sqrt{108.2(523-108.2)} = -212 \text{ ohms}$

From equation (3) $X_2 = -\frac{11710}{-212} + 212 = 267.2 \text{ ohms}$

From equation (4) $\tan \frac{2\pi A}{\lambda g} = -\frac{52}{-212} = 0.245$

so: $\frac{2\pi A}{\lambda g} = 13.8^\circ$

From equation (5) $A = \frac{13.8}{0.04572 \times 14.15} = 21.3 \text{ in.}$

To find Z_{02} from figure 3: $\frac{D}{d} = \frac{3}{3/8} = 8$ and $Z_{02} = 330 \text{ ohms}$

From equation (6) $\tan \frac{2\pi B}{\lambda} = \frac{267.2}{330} = 0.81$

so: $\frac{2\pi B}{\lambda} = 39.0^\circ$

From equation (7) $B = \frac{39}{0.366 \times 14.15} = 7 \text{ ft. } 6.5 \text{ in.}$

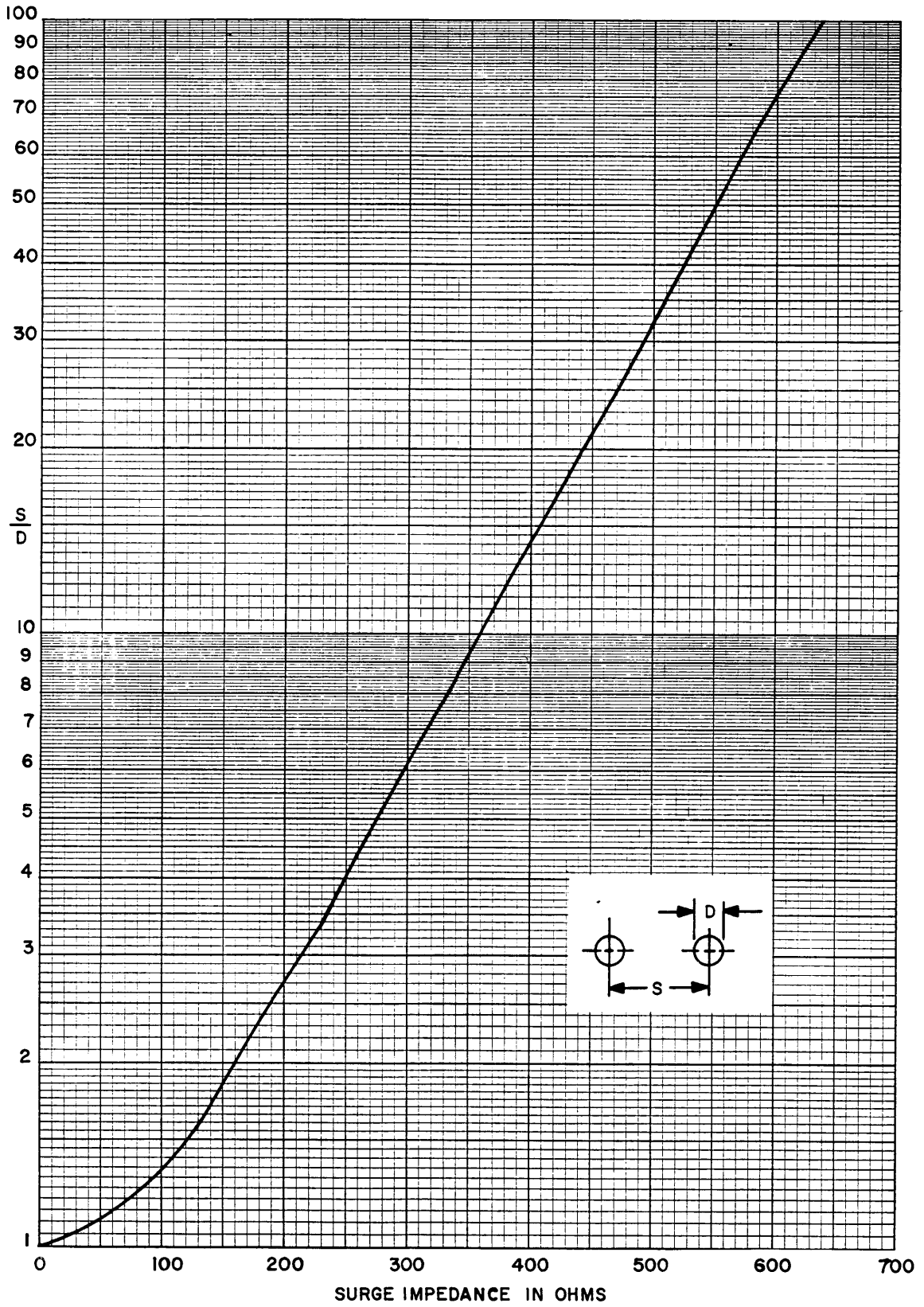

Figure 7-3. Open Wire Line Impedance Chart

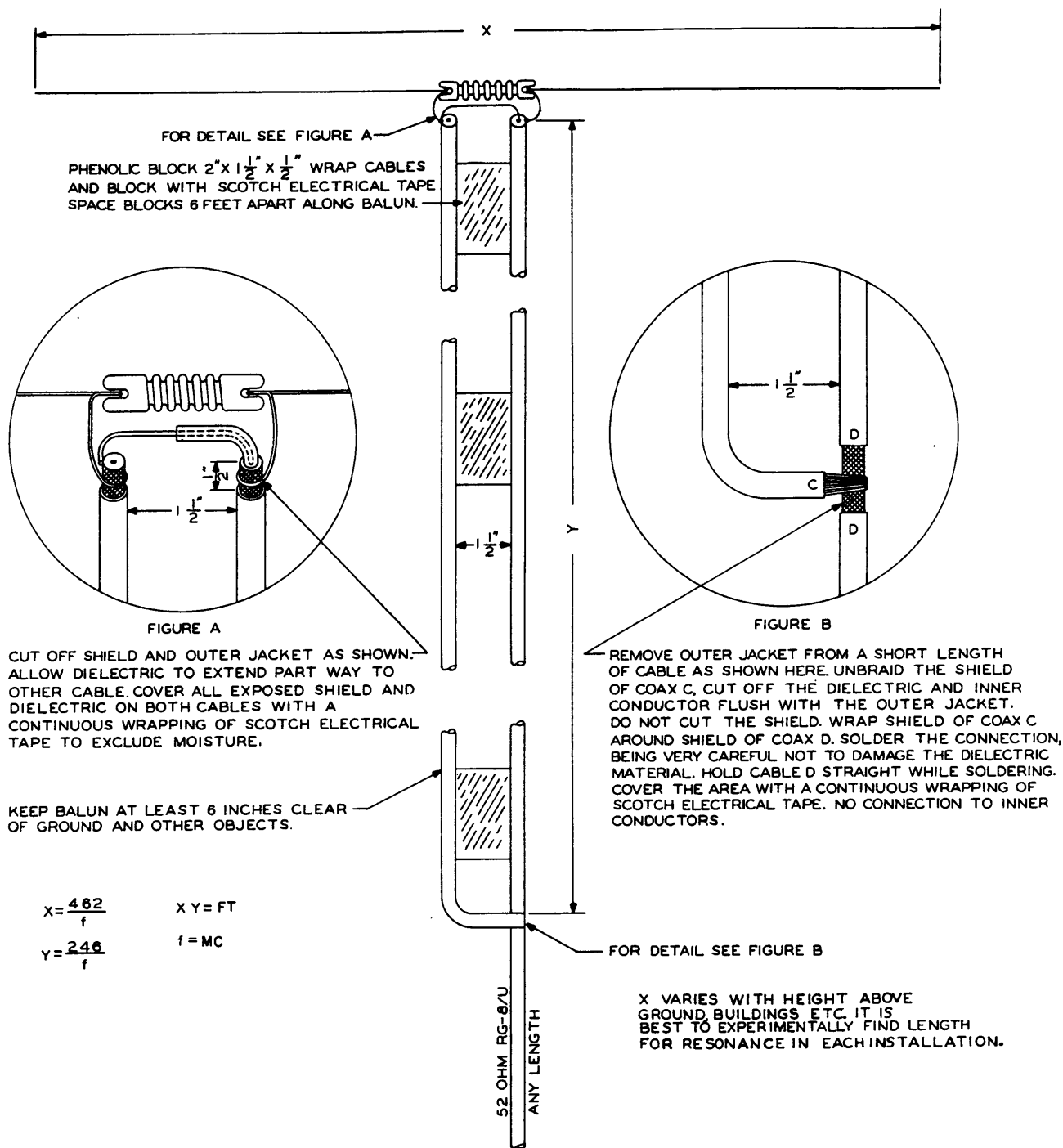

Figure 7-4. Half-Wave Antenna with Quarter-Wave Balun

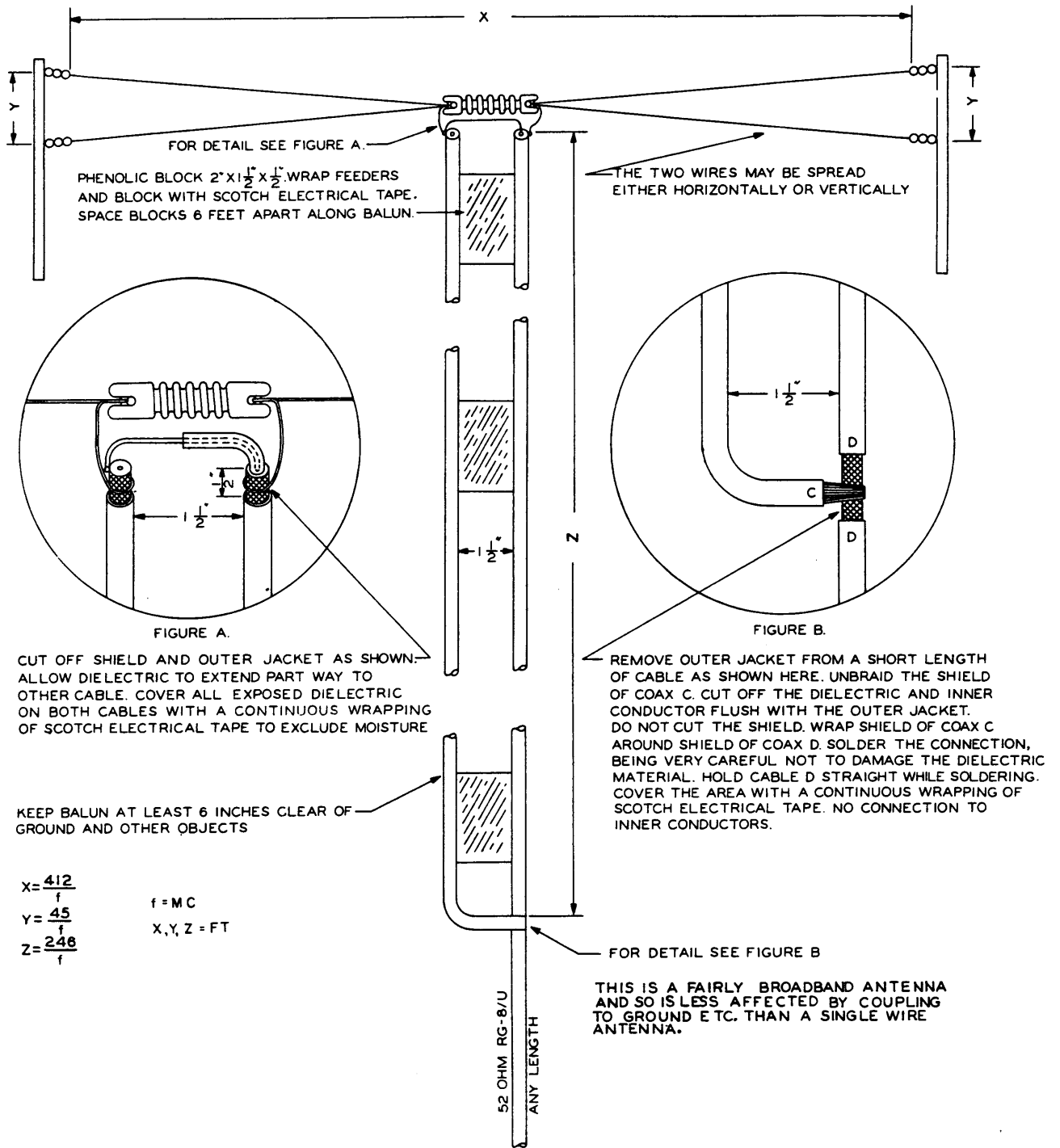

Figure 7-5. Broadband Antenna with Quarter-Wave Balun

FIELD SERVICE
ENGINEERING
LIBRARY COPY