

INSTRUCTION BOOK

FOR

MODEL 30K-1 AMATEUR TRANSMITTER

AND

310A-1 EXCITER

SECOND EDITON

MANUFACTURED BY

COLLINS RADIO COMPANY, CEDAR RAPIDS, IOWA

*Collins Radio Co. 320 Walnut St. W1235 N.E.
AMI. ENCL. ON 3 COND. TAPS ON 5*

INSTRUCTION BOOK

*10. to be added to the 1000
operation in the 1000
and 1000 on it
for
all the 1000 on it
1000 on it*

MODEL 30K AMATEUR TRANSMITTER

SECOND EDITION

MANUFACTURED BY

COLLINS RADIO COMPANY, CEDAR RAPIDS, IOWA

520 9343 00

12691-1

TABLE OF CONTENTS

<u>Par.</u>	<u>Page</u>	<u>Par.</u>	<u>Page</u>
SECTION 1 - GENERAL DESCRIPTION			
1. General	1-1	b. Frequency Range	1-5
2. Mechanical Description	1-1	c. Frequency Control	1-5
a. Overall Dimensions	1-2	d. Types of Emission	1-5
b. Weight	1-2	e. Nominal Carrier Output	1-5
c. Finish	1-2	f. Power Requirements	1-5
d. Construction	1-2	g. Input Impedance (Microphone)	1-5
3. Electrical Description	1-2	h. Output Impedance (Antenna)	1-6
a. General	1-2	i. Ambient Temperature Range	1-6
b. Radio Frequency Section	1-2	j. Keying Speed	1-6
c. Audio Section	1-3	k. Audio Characteristics	1-6
d. Antenna Coupling	1-4	6. Vacuum Tube Complement	1-6
4. Accessories	1-4	a. 3LOA Exciter Unit	1-6
5. Reference Data	1-4	b. 3OK Transmitter Unit	1-6
a. List of Major Units	1-4		
SECTION 2 - THEORY OF OPERATION			
1. Mechanical	2-1	c. Radio Frequency Section	2-2
a. General	2-1	d. Audio Circuits	2-4
2. Electrical	2-1	e. Metering Circuits	2-6
a. General	2-1	f. Antenna Termination	2-6
b. Primary Power Circuits	2-1		
SECTION 3 - INSTALLATION AND INITIAL ADJUSTMENT			
1. Installation	3-1	2. Initial Adjustments	3-7
a. Preliminary	3-1	a. General	3-7
b. Installation Procedure	3-1	b. Filament Voltage	3-7
		c. Exciter Unit	3-7
SECTION 4 - OPERATION			
1. Starting the Equipment	4-1	5. Tuning Instructions	4-3
a. Procedure	4-1	a. Exciter Unit	4-3
2. Stopping the Equipment	4-1	b. Transmitter Unit	4-4
a. Procedure	4-1	6. Speech Clipper Adjustment	4-5
3. General	4-1	a. Speech Clipper Out	4-5
a. Functions of the Equipment	4-1	b. Speech Clipper In	4-5
b. Operating Precautions	4-2	7. CW Operations	4-6
4. Routine Operation	4-2	8. Typical Meter Readings	4-6
a. Panel Control	4-2	a. CW Operation	4-6
b. Remote Control	4-3	b. Phone Operation	4-6
SECTION 5 - MAINTENANCE			
1. Inspection	5-1	b. Fuses	5-4
a. General	5-1	3. Alignment	5-4
b. Routine Inspection	5-1	a. General	5-5
2. Trouble Shooting	5-3	b. High Frequency Oscillator	5-5
a. General	5-3	c. Exciter Stages	5-6
SECTION 6 - SUPPLEMENTARY DATA			
1. Typical Meter Readings	6-1	b. CW Emission	6-1
a. Phone Emission	6-1		
SECTION 7 - PARTS LIST			
SECTION 8 - ILLUSTRATIONS			

LIST OF ILLUSTRATIONS

Figure

Title

1-1	Model 30K, Complete Installation
1-2	Model 30K Transmitter
1-3	Model 310A Exciter
2-1	Primary Power Circuits
2-2	Speech Clipper Circuit
3-1	Transmitter Outline and Mounting Dimensions
3-2	Exciter Outline Dimensions
3-3	Transmitter, Rear Open
3-4	Applicable Antenna Tuning Circuits
3-5	Possible Auxiliary Circuits
4-1	Functions of Controls
4-2	Typical Dial Readings
5-1	Exciter Alignment Adjustments
8-1	Output Coil and Switch Assembly, Top View
8-2	Output Coil and Switch Assembly, Bottom View
8-3	Power Amplifier Tube Chassis, Top View
8-4	Power Amplifier Tube Chassis, Bottom View
8-5	Speech Amplifier and Modulator, Top View
8-6	Speech Amplifier and Modulator, Bottom View
8-7	Low Voltage and Bias Supply, Top View
8-8	Low Voltage and Bias Supply, Bottom View
8-9	High Voltage Rectifier Unit, Top View
8-10	High Voltage Rectifier Unit, Bottom View
8-11	Exciter Unit, Top Open View
8-12	Exciter Unit, Bottom Open View
8-13	30K Transmitter Schematic Diagram
8-13	30K Transmitter Schematic Diagram, Detachable Copy
8-14	310A Exciter Unit Schematic Diagram
8-14	310A Exciter Unit Schematic Diagram, Detachable Copy

WARNING

OPERATION OF THIS EQUIPMENT INVOLVES THE USE OF HIGH VOLTAGES WHICH ARE DANGEROUS TO LIFE. OPERATING PERSONNEL SHOULD AT ALL TIMES OBSERVE ALL THE SAFETY RULES LISTED BELOW. DO NOT CHANGE TUBES OR MAKE ADJUSTMENTS INSIDE EQUIPMENT WITH HIGH VOLTAGE SUPPLY ON. DO NOT DEPEND UPON DOOR SWITCHES FOR PROTECTION BUT ALWAYS SHUT DOWN POWER EQUIPMENT AND OPEN MAIN SWITCH IN POWER SUPPLY CIRCUIT. ALWAYS DISCHARGE AND GROUND CIRCUITS PRIOR TO TOUCHING THEM.

Since the use of high voltages which are dangerous to human life is necessary to the successful operation of the radio transmitting equipment covered by these instructions, certain precautionary measures must be carefully observed by the operating personnel during the adjustment and operation of the equipment.

The major portions of the equipment are within metal cabinet enclosures, provided with access doors which are generally fitted with safety interlock switches which remove dangerous voltages within the cabinets when access doors are open.

Interlocks are also provided on certain removable panels within the cabinets. Other panels, if removed, will not cause interlocks to function and will thereby allow access to circuits carrying voltages dangerous to human life.

KEEP AWAY FROM LIVE CIRCUITS: Under no circumstances should any person reach within a cabinet with interlocked gates while power supply line switches to the equipment are closed; or handle any portion of exposed equipment which is supplied with power; or to connect any apparatus external to the cabinets to circuits within the cabinets; or to apply high voltages to the equipment even for testing purposes while any non-interlocked portion of the cabinet is removed. Whenever feasible in testing circuits, make continuity and resistance checks rather than directly checking voltage at various points when any high voltage is applied to the transmitter circuits.

DON'T SERVICE OR ADJUST ALONE: Under no circumstances should any person reach within a cabinet for the purpose of servicing or adjusting the equipment without the presence or assistance of another person capable of rendering aid.

DON'T TAMPER WITH INTERLOCKS: Door or safety interlock switches should not be removed or short circuited, nor should reliance be placed upon the interlock switches for removing voltages from the equipment.

REPLACEMENT OF PARTS

In case a replacement under the guarantee is desired, a full report must be submitted to the company. This report shall cover all details of the failure and must include the following information:

- (A) Date of delivery of equipment.
- (B) Date placed in service.
- (C) Number of hours in service.
- (D) Part number of item.
- (E) Item number (obtain from Parts List or Schematic Diagram).
- (F) Type number of unit from which part is removed.
- (G) Serial number of unit.
- (H) Serial number of the complete equipment.
- (I) Nature of failure.
- (J) Cause of failure.
- (K) Remarks.

When requisitioning replacement parts, the following information must be furnished:

- (A) Quantity required.
- (B) Part number of item.
- (C) Item number (obtain from Parts List or Schematic Diagram).
- (D) Type number of unit.
- (E) Serial number of unit.
- (F) Serial number of equipment.

NOTE: Blank Service Report forms will be found in the appendix of this instruction book.

MODEL 30K TRANSMITTER

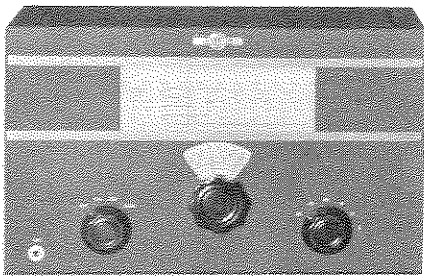

MODEL 310A EXCITER

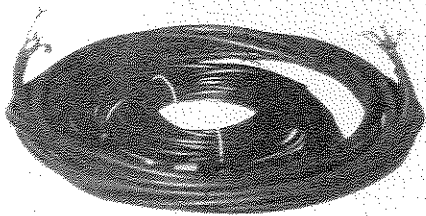

CONNECTING CABLES
MICROPHONE - 425 0018 00
RF INTERCONNECTING - 503 0907 002
POWER INTERCONNECTING - 503 0906 002

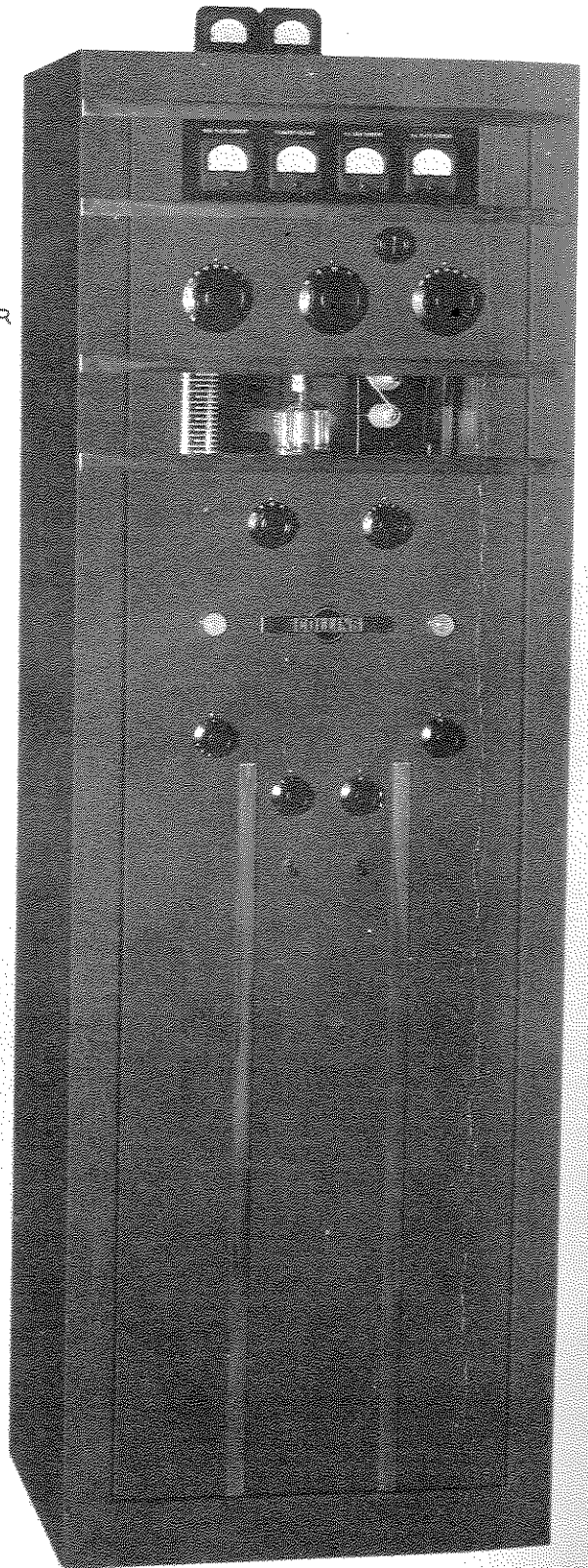

FIGURE I-1 COMPLETE INSTALLATION

SECTION 1

GENERAL DESCRIPTION

1. GENERAL.

This instruction book has been prepared to assist in the proper installation adjustment, operation, and maintenance of the Collins Type 30K Radio Transmitting Equipment.

The Type 30K Transmitting Equipment, figure 1-1, is a transmitter designed to fulfill the communication requirements of a modern amateur radio station. The unit embodies features which follow the trend of operating practices necessitated by increasingly strict governing regulations and well populated amateur band conditions. Among these features are: Complete coverage of the 80, 40, 20, 15, 11 and 10 meter bands (The 15 meter band is unauthorized at present.); quick band-change by means of switches; continuous frequency coverage within the amateur bands by means of a highly stabilized master oscillator; frequency calibration within one kc on 40 meters; a speech clipper to prevent overmodulation; and an audio response especially effective in speech communication.

Other features of the 30K Transmitter are: high efficiency; modern tubes and circuits; adequate metering; conservative ratings; safety door interlock switch; and remote control from the operating position. The Collins Type 310A Exciter Unit, furnished with the equipment, is designed for mounting on the operating table near the operator. With the exception of the filament switch, all controls necessary for turning the equipment on and off are located on the exciter unit front panel.

The transmitter contains antenna tuning equipment which is capable of coupling the power amplifier plate circuit to an untuned transmission line of any impedance or to a tuned line of any multiple of a quarter wave in length. It will also function to couple the transmitter into an unbalanced antenna such as the Marconi, end fed Hertz or end fed Zepp. Antenna tuning and loading controls are located on the front panel. Three pairs of antenna terminals are provided and by connecting jumpers in the BAND switch the bands may be paired up as desired or all bands may be connected to one pair of antenna terminals.

An extra switch section is placed on the power amplifier grid band switch which can be used to operate antenna relays, etc., automatically when the band is changed.

2. MECHANICAL DESCRIPTION.

GENERAL DESCRIPTION

a. OVERALL DIMENSIONS.

(1) 30K TRANSMITTER UNIT. - 21-7/8" wide x 66-1/2" high x 18-15/16" deep including control knobs on front and door handle and antenna feedthrus on rear.

(2) 310A EXCITER UNIT. - 17-1/4" wide x 10-11/16" high x 13-7/16" deep including control knobs on front.

b. WEIGHT.

(1) 30K TRANSMITTER UNIT. - 355 lbs.

(2) 310A EXCITER UNIT. - 50 lbs.

c. FINISH. - Both the transmitter unit, figure 1-2, and the exciter unit, figure 1-3, are finished in St. James Gray wrinkle finish with polished stainless steel trim.

d. CONSTRUCTION. - The Cabinet of the 30K Transmitter Unit is constructed of heavy sheet steel plates formed and welded together. Access to all units is through a full length rear door. Access to the tubes in the Model 310A Exciter Unit is through a hinged top cover.

3. ELECTRICAL DESCRIPTION.

a. GENERAL. - High overall operating efficiency is attained by the use of tetrode and beam power tubes throughout the equipment, where applicable, and by the use of Class B, high level, amplitude modulation. A power input of 375 watts phone or 500 watts CW is possible on all bands. A speech clipper is incorporated in the audio section so that sideband power can be greatly increased without overmodulation. Frequency control is obtained by the use of a highly stabilized, accurately calibrated master oscillator.

b. RADIO FREQUENCY SECTION.

(1) EXCITER UNIT. - The master oscillator, which is heavily shielded and temperature compensated, employs a Type 6SJ7 radio tube. The grid circuit of

GENERAL DESCRIPTION

the master oscillator tube is permeability tuned by a powdered iron slug. The master oscillator tuning control is ganged to the frequency multiplier tuning controls and is operated by the main tuning control which is calibrated to within .015 percent. Following the master oscillator tube is a Type 6AG7 tube in an untuned stage which operates on the same frequency as the master oscillator and isolates the oscillator from the frequency multiplier stages.

Following the Type 6AG7 untuned stage is the first tuned doubler amplifier. This stage employs a Type 6AG7 tube also and is tuned to the 80 meter band or twice the frequency of the master oscillator by a variable capacitor ganged with the master oscillator tuning control.

The frequency multiplier stage, a Type 807 beam amplifier tube, is tuned to 80, 40, 30, or 20 meters, as needed, by a variable capacitor and coils selected by a tap switch. The third r-f stage is always used as a doubler except when the final amplifier is operating in the 80 meter band, in which case, the third stage works straight through on 80 meters. The variable capacitors employed to tune the second and third r-f stages are ganged with the master oscillator tuning control. Excitation of the grid of the power amplifier tube in the 30K unit is accomplished by pick-up coils coupled to the second multiplier plate coils and connected to a small coaxial transmission line which connects to the grid circuit of the power amplifier tube. The transmitter is keyed by breaking the cathode circuit of the type 6AG7 first doubler stage. All subsequent stages including the power amplifier stage are biased to plate current cut off with no excitation.

(2) TRANSMITTER UNIT. - Excitation from the second multiplier stage in the exciter unit is carried through a coaxial transmission line and coupled to the power amplifier grid circuit which is tuned to the transmitting frequency. Band switching by means of tap switches is employed in the grid and plate circuits of the power amplifier.

c. AUDIO SECTION.

(1) TRANSMITTER UNIT. - All audio circuits, which consist of voltage amplifier, speech clipper, high frequency filter, driver and modulator circuits, are located in the transmitter unit. Any high impedance microphone, such as a crystal microphone or high impedance dynamic, may be used. The microphone cable connects directly into the rear of the speech amplifier unit in the transmitter.

A Type 6SJ7 and one section of a Type 6SN7 dual triode tube provide audio voltage amplification. A type 6H6 dual diode tube is employed in a clipper circuit to clip both positive and negative audio peaks at a predetermined

GENERAL DESCRIPTION

level to provide greater sideband power without overmodulation. All high, less useful speech frequencies are attenuated by a cut-off filter designed for 4000 cps cut-off. A Type 6B4G tube is used to drive the grids of the Type 75TH modulator tubes. The modulators are capable of modulating the r-f carrier 100% with an audio response which is within 3 db from 100 to 4000 cps.

d. ANTENNA COUPLING. - Because of the great variety of antennas in use in amateur stations an extremely flexible antenna coupling circuit has been incorporated in the transmitter. To meet the complete frequency coverage requirements, it was found advisable to use plug-in units in the antenna tuning apparatus. Any type of antenna or transmission line can be tuned with the two plug-in units supplied. Both the tuning and the loading are controllable from the front panel. Either series or parallel tuning can be had with any value of inductance. The ends of the antenna coil are connected to a pair of rotor contacts in the power amplifier plate band switch, the stator contacts of which can be connected to any one of three pairs of antenna terminals. These stator contacts can be jumpered to get any combination of antenna terminals desired, however, all are jumpered together and connected to the center pair of antenna terminals when shipped from the factory. An extra switch section is placed on the power amplifier grid band switch which can be used to operate antenna relays, etc., automatically when the band is changed.

4. ACCESSORIES.

The Model 30K amateur transmitter is supplied complete with tubes, fuses and interconnecting cables. It will be necessary to have the following apparatus in order to complete the transmitting installation:

- a. Any high impedance microphone such as a crystal or high impedance dynamic.
- b. A telegraph key.
- c. A suitable radiating system.
- d. A 115 volt 60 cps power source capable of 1350 watts continuous load.

5. REFERENCE DATA.

- a. LIST OF MAJOR UNITS.

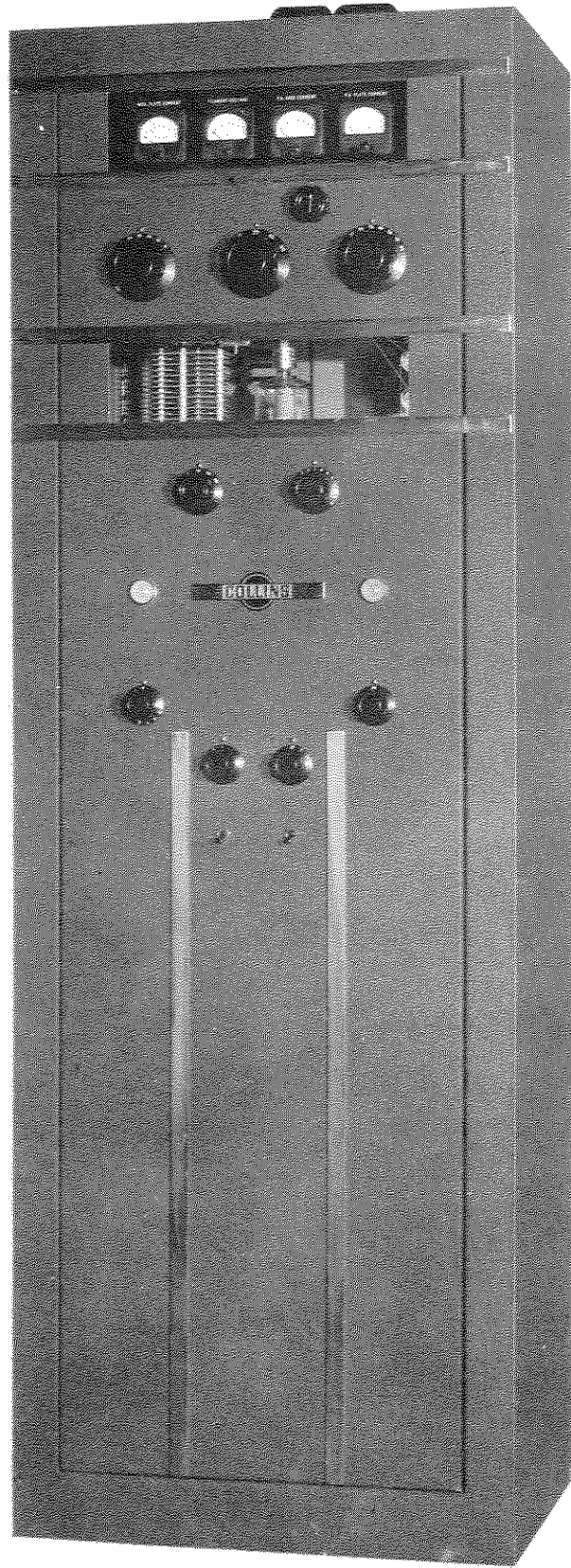

FIGURE 1-2 MODEL 30K TRANSMITTER

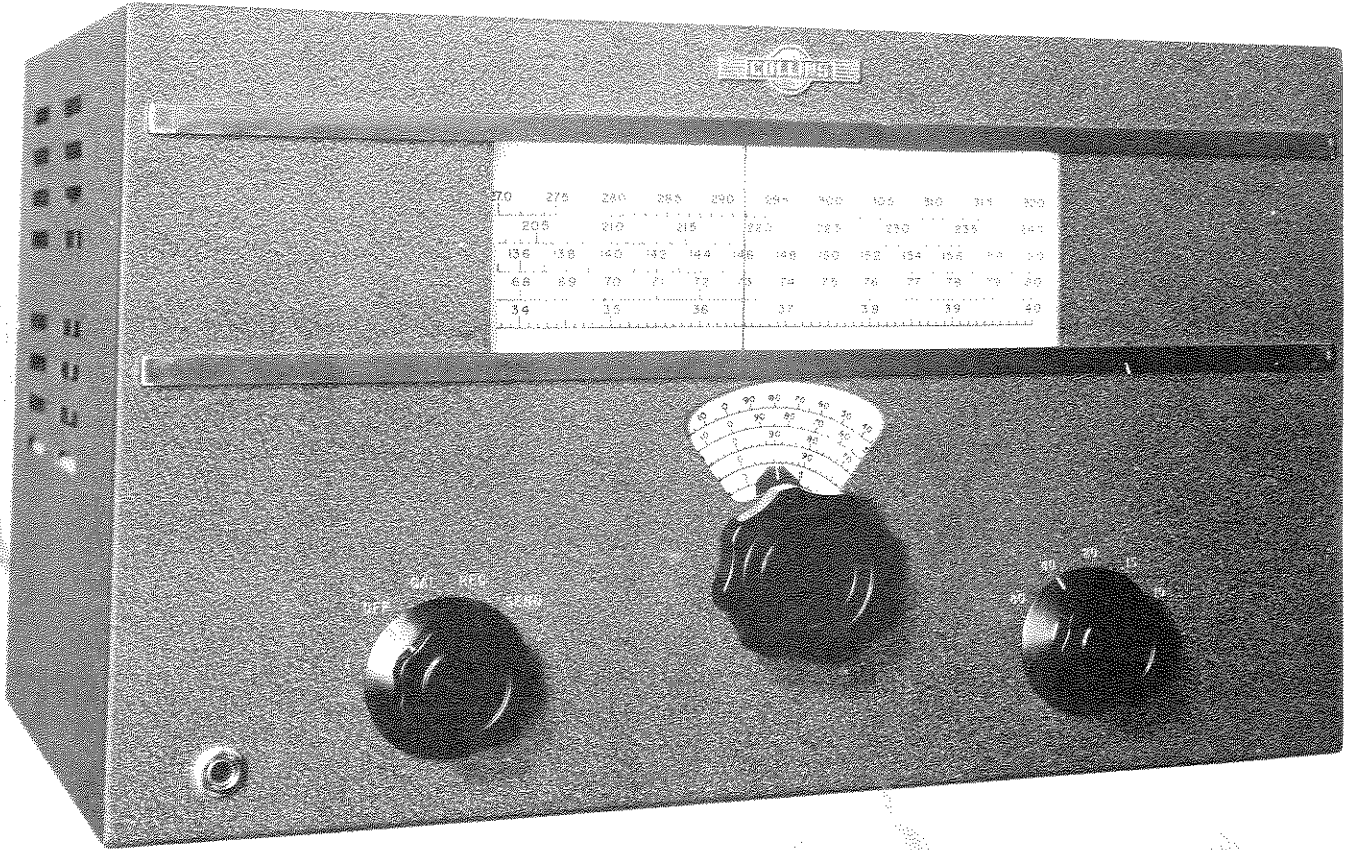

FIGURE 1-3 MODEL 310A EXCITER

GENERAL DESCRIPTION

MAJOR UNIT	SUB ASSEMBLY	DESCRIPTION
30K		TRANSMITTER UNIT
	520 3508 00	Power amplifier tank assembly
	520 2886 00	Power amplifier chassis assembly
	520 2887 00	Speech amplifier assembly
	520 2888 00	L-V Bias assembly
	520 2889 00	H-V Rectifier assembly
	520 3509 00	80 - 40 meter ant tank coil
	520 3510 00	20 - 15 - 10 meter ant tank coil

310A

EXCITER

503 0906 002	TRANSMITTER-EXCITER INTERCONNECTING CABLE
503 0907 002	COAXIAL RF CABLE (23.5 ft)
425 0018 00	MICROPHONE CABLE

b. FREQUENCY RANGE. - 10, 15, 20, 40 and 80 meter amateur bands only. (The 15 meter band is unauthorized at this time.)

c. FREQUENCY CONTROL. - Highly stabilized variable frequency oscillator.

d. TYPES OF EMISSION. - Amplitude modulated phone and CW. 100% modulation of carrier possible.

e. NOMINAL CARRIER OUTPUT. - 250 watts phone, 300 watts CW.

f. POWER REQUIREMENTS. - With a 115 volt 60 cps power source the following power is required: (Power amplifier loaded to 200 ma CW and 150 ma phone.)

CONDITIONS	CURRENT (AMPS)	POWER (WATTS)	V.A.	POWER FACTOR
Filaments ON, CW	1.75	140	202	70.0
Filaments ON, Phone	2.32	250	267	94.0
Carrier ON, CW	10.0	1000	1150	87.0
Carrier ON, Phone	10.2	1025	1175	87.5
Carrier ON, Phone 100% continuous modulation	10.5	1350	1555	87.0

g. INPUT IMPEDANCE (MICROPHONE). - High impedance dynamic or crystal.

GENERAL DESCRIPTION

h. OUTPUT IMPEDANCE (ANTENNA). - Any antenna impedance which has little reactance.

i. AMBIENT TEMPERATURE RANGE. - 0 degrees C (32°F) to 40 degrees C (104°F)

j. KEYING SPEED. - 75 WPM.

k. AUDIO CHARACTERISTICS.

(1) RESPONSE. - Within 3 db from 100 to 4000 cps. A cutoff filter is used to attenuate all frequencies above 4000 cps.

(2) AMPLITUDE DISTORTION. - Less than 10% total RMS harmonic distortion (clipper tube removed) up to 100% modulation at 1000 cps.

6. VACUUM TUBE COMPLEMENT.

a. 310A EXCITER UNIT.

<u>SYMBOL</u>	<u>TYPE</u>	<u>FUNCTION</u>
V001	6SJ7	Master oscillator
V601	6AG7	Isolation buffer
V602	6AG7	Frequency doubler
V603	807	Frequency multiplier
V604	807	Frequency doubler
V605	VR105	Voltage regulator
V606	VR105	Voltage regulator
V607	6X5GT	Rectifier
V608	5R4GY	Rectifier

b. 30K TRANSMITTER UNIT.

<u>SYMBOL</u>	<u>TYPE</u>	<u>FUNCTION</u>
V201	4-125A	Power amplifier
V301	6SJ7	Audio amplifier
V302	6SN7	Dual audio amplifier
V303	6H6	Speech clipper
V304	6B4G	Audio driver
V305	75TH	Modulator
V306	75TH	Modulator
V401	5R4GY	Bias rectifier
V402	5R4GY	LV rectifier
V501	866A	HV rectifier
V502	866A	HV rectifier

SECTION 2

THEORY OF OPERATION

1. MECHANICAL.

a. GENERAL. - The complete 30K Transmitting Equipment consists of two units, the transmitter unit and the exciter unit. The transmitter unit is contained in a floor mounting cabinet while the exciter unit is constructed smaller for table mounting. Flexible interconnecting cables are employed between the two units.

The components of the transmitter unit are placed on removable chassis which are constructed of heavy gauge aluminum. All power and control wires between the various units are laced together in nicely formed cables. Connections to the units are made to terminal strips having insulating barriers between the individual screw terminals.

The exciter unit is constructed on an aluminum chassis contained within a steel cabinet which is suitable for table mounting.

The various chassis may be removed from the rear of the transmitter cabinet by removing the control knobs from units so equipped, removing the four bolts which secure the chassis to the mounting cleat, and disconnecting the cable from the terminal strip. (A set of Bristo wrenches is fastened to the rear door for loosening set screws in control knobs.) The transmitter cabinet is equipped with a full length rear door. A glass covered opening in the front panel allows a continuous check on the color of the plate of the power amplifier tube. The meter panel is also behind a glass covered opening in the front panel thereby, in the interest of safety, making a completely dead panel. The antenna current meters are located externally at the top rear edge of the transmitter cabinet. This feature allows shorter connecting leads, making more accurate current readings possible.

2. ELECTRICAL.

a. GENERAL. - A master-oscillator-power amplifier circuit is employed in the 30K Transmitting Equipment to give 375 watts input to the final amplifier on phone and 500 watts input on CW. The final amplifier is high level amplitude modulated with Class "B" modulator tubes.

b. PRIMARY POWER CIRCUITS. - Refer to figure 2-1. The filament transformers T303, T403, and T501 and the bias supply transformer T401 are energized when the FILAMENT switch S103 is closed. Each of the above transformers is protected by a fuse. The primary adjustment taps on filament transformer T403 are brought out to a tap switch S101 which is used to adjust the filament voltage to the PA and modulator tubes. Low voltage plate transformer T402 and high voltage plate transformer T101 are energized by the operation of plate power relay K401 which is operated when the PLATE switch is closed. Since operating voltage

THEORY OF OPERATION

for the plate power relay coil is obtained from the bias power supply, the primary power cannot be applied to the low and high voltage transformers until the bias supply is operating thus preventing applying plate power to the power amplifier and modulator tubes when there is no fixed bias. A door switch, S105, operated by the rear access door also interlocks the low and high voltage power supplies to prevent accidental shocks; however, since this unit operates with voltages which are extremely dangerous to life, interlock switches should not be depended upon when working on the unit, rather, completely disconnect the primary source of power by means of a conveniently located main power switch.

The TUNE-OPERATE switch S102 is provided with a large resistor in the TUNE position which reduces the primary power to the high voltage transformer during the tuning procedure. The PLATE power switch in the transmitter unit is interlocked with the POWER switch in the exciter unit in such a manner that the transmitter high voltage cannot be turned ON until the exciter plate power is turned ON.

The function of the exciter POWER switch is as follows:

<u>POSITION NUMBER</u>	<u>POSITION NAME</u>	<u>FUNCTION</u>
1	OFF	All transmitter plate and exciter plate and filament circuits inoperative. Receiver interlock circuit closed. (Does not remove transmitter filament power.)
2	CAL	Exciter plate and filaments operative. Receiver interlock circuit closed. Transmitter plate circuits inoperative.
3	REC	All transmitter and exciter circuits inoperative. All filament circuits operative. Receiver interlock circuit closed.
4	SEND	All transmitter and exciter filament and plate circuits operative. Receiver interlock circuit open.

c. RADIO FREQUENCY SECTION.

(1) EXCITER UNIT. - A Type 6SJ7 tube is employed in a highly stabilized master oscillator circuit to generate the controlling radio frequency voltage. The oscillator circuit is compensated for temperature changes and is entirely

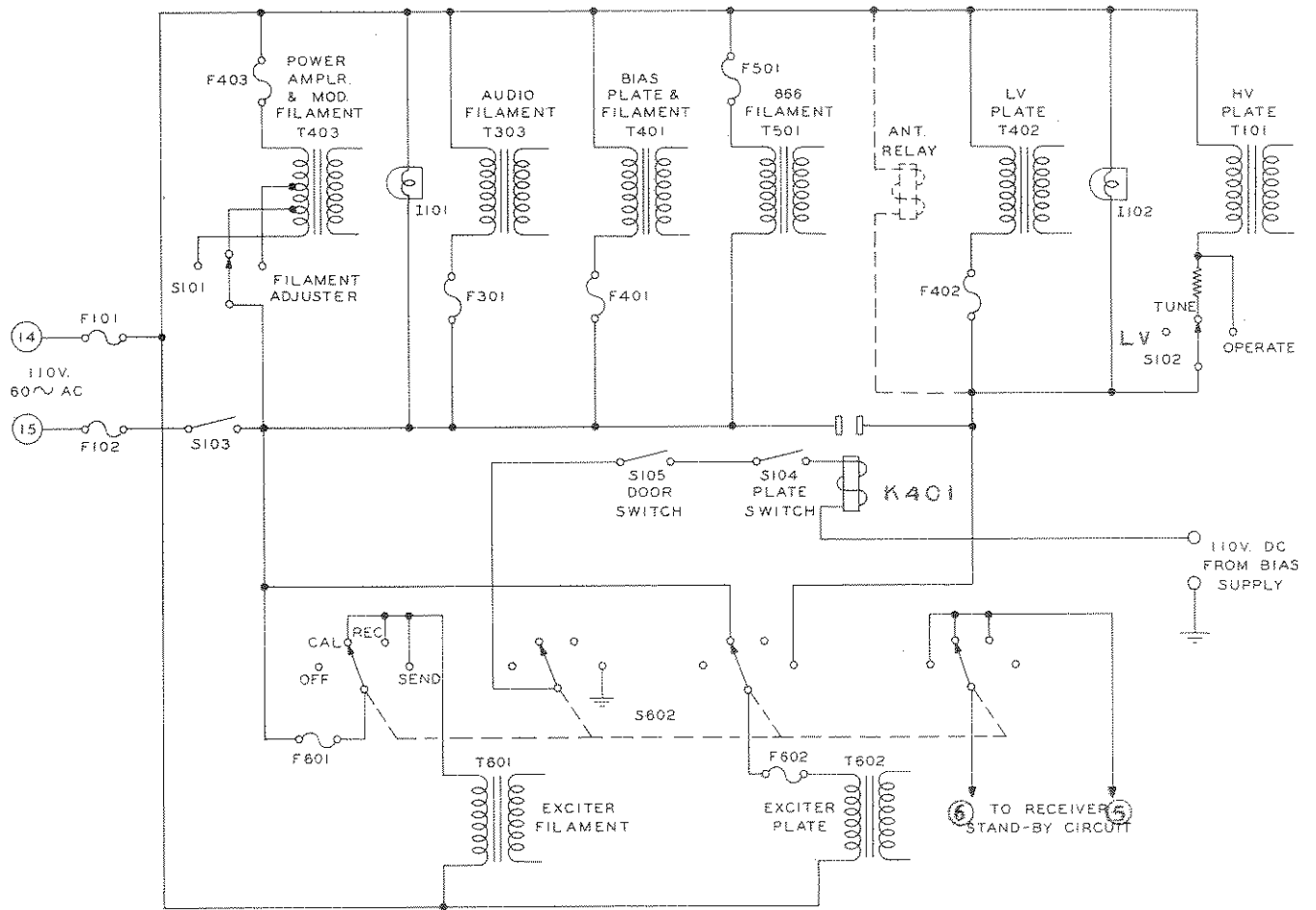

Figure 2-1 Primary Power Circuits

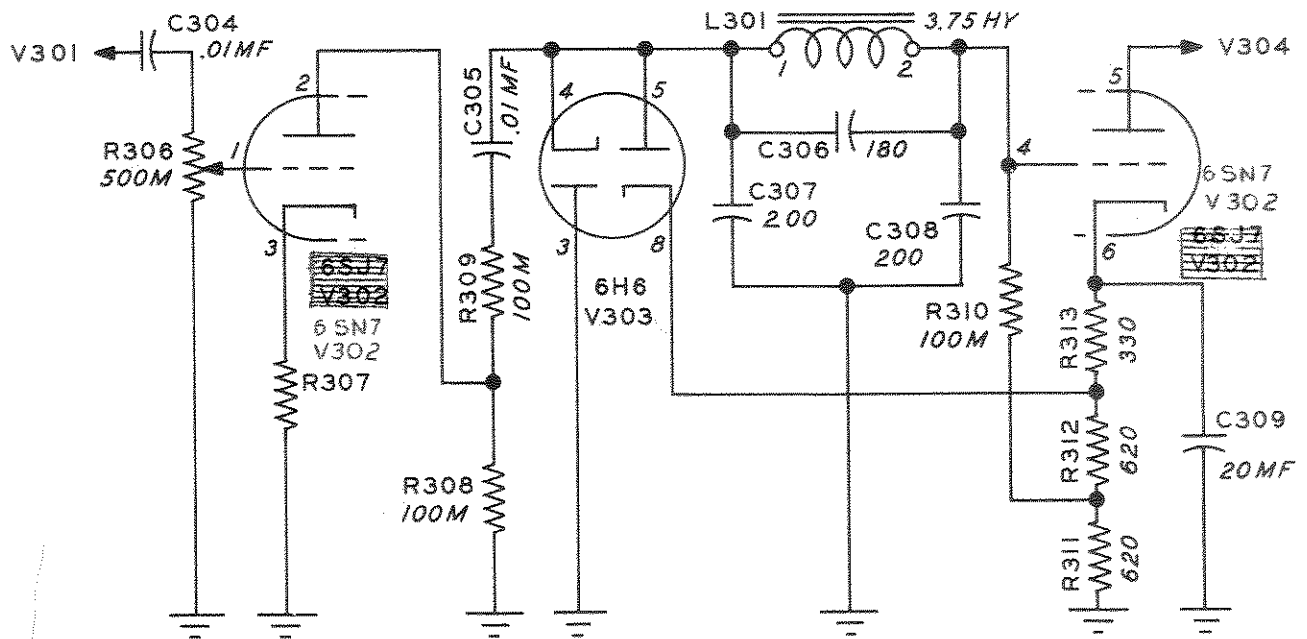

Figure 2-2 Speech Clipper Circuit

THEORY OF OPERATION

enclosed in a heavy aluminum case. The oscillator operates in the 1.6875 to 2.0 mc frequency range and the oscillator output is in this same range. The oscillator is permeability tuned with a powdered iron slug driven by a threaded shaft which is connected to the main tuning dial.

The output of the oscillator is coupled to the grid of a 6AG7 buffer stage. This stage is untuned and operates over the frequency range of the oscillator. The principal purpose of this stage is to isolate the master oscillator from the more powerful frequency multiplier stages which follow. Immediately following the isolation buffer stage is a tuned frequency-doubler employing a 6AG7 tube. This stage doubles the frequency of the oscillator in all cases.

The output of the 6AG7 doubler stage is coupled to an 807 frequency multiplier stage by capacitor C607. This stage doubles, triples, or quadruples the frequency as needed. It also operates straight-through when the transmitter output frequency is in the 80 meter band. In order to get to the 15 meter band, this stage triples the frequency from 80 meters to 30 meters from where the frequency is doubled to 15 meters by the following 807 frequency multiplier tube. The grid excitation to the 807 frequency doubler tube, which follows, is maintained at a nominal amount by adding cathode bias to the 807 frequency multiplier tube. A tap switch section, ganged to the band switch, switches extra resistance in to the cathode circuit of the 807 frequency multiplier tube when a lesser amount of grid excitation to the 807 frequency doubler is needed. One section of the band switch selects the proper multiplier coil while another section of the band switch short circuits the unused coils.

Capacitor C115 couples the Type 807 frequency multiplier stage to the 807 frequency doubler stage. The 807 doubler stage is always used as a doubler except when the transmitter output is in the 80 meter band where it is used as an amplifier on the fundamental frequency. Two sections of the band switch are used in this stage, one to select the proper plate coil and one to short out the unused coils. Each output coil has a pick-up coil wound over it to pick-up the excitation power for the power amplifier grid. This pick-up coil is selected by a section of the band switch.

Both 807 tubes are biased to plate current cut-off by the bias power supply. Additional bias is obtained by the use of grid leak resistors in the grid circuits of both tubes and by cathode resistors in the case of the multiplier tube.

Plate voltage to all stages in the exciter unit is furnished by a step-up transformer and a 5R4GY high vacuum rectifier. A tap is taken off the high voltage winding for the 6X5GT blocking bias rectifier. Filament power for all tubes is obtained from a filament transformer. The primary circuits of both

THEORY OF OPERATION

transformers are fused for protection against short circuits.

(2) TRANSMITTER UNIT. - The power amplifier for the Collins Model 30K Amateur Transmitter is located in the transmitter unit. Employing a Type 4-125A tetrode tube, the power amplifier requires a minimum of driving power and needs no neutralizing circuit. Band switching is used throughout the r-f circuits. The power amplifier is used straight-through on all bands and is never used as a frequency doubler. Grid excitation is received from the Model 310A Exciter unit via the link coupling. Both the grid and the plate circuits of the 4-125A tube are tuned to the output frequency. Special effort has been made to isolate the grid circuit from the plate circuit to prevent interaction. The band switch sections in both the grid and plate tuning circuits select the proper coils for the band in which operation is desired and, in most instances, short circuits the remaining unused coils.

The control grid of the power amplifier tube is biased to plate current cut-off by voltage from the bias supply. Additional bias is obtained from the voltage drop across grid leak R201. Screen voltage for the 4-125A tube is obtained from the low voltage power supply. Plate voltage for the power amplifier tube is obtained from the high voltage plate supply which employs a pair of 866A mercury vapor rectifier tubes in a full wave circuit.

One half of the plate circuit tuning variable capacitor C207 is employed during operation in the 10, 15, 20 and 40 meter bands while both halves of the capacitor are connected in parallel for 80 meter operation.

CIRCUIT FREQUENCIES vs OUTPUT FREQUENCY

OUTPUT FREQUENCY	CIRCUIT						
	V601 GRID	V602 PLATE	V603 PLATE	V604 PLATE	V605 PLATE	V201 GRID	V201 PLATE
3.5 mc	1.75 mc	1.75 mc	3.5 mc	3.5 mc	3.5 mc	3.5 mc	3.5 mc
7 mc	1.75 mc	1.75 mc	3.5 mc	3.5 mc	7 mc	7 mc	7 mc
14 mc	1.75 mc	1.75 mc	3.5 mc	7 mc	14 mc	14 mc	14 mc
21 mc	1.75 mc	1.75 mc	3.5 mc	10.5 mc	21 mc	21 mc	21 mc
28 mc	1.75 mc	1.75 mc	3.5 mc	14 mc	28 mc	28 mc	28 mc

d. AUDIO CIRCUITS.

(1) GENERAL. - The audio system of the transmitter is completely contained in the transmitter cabinet. A high gain microphone amplifier is

THEORY OF OPERATION

followed by a two stage audio amplifier which is shunted by a speech clipper tube. The output of the audio amplifier is used to excite a driver stage which drives the grids of the Class B modulator tubes.

100% modulation is attained by the use of any high impedance microphone such as a crystal or high impedance dynamic. The speech clipper clips both the negative and the positive audio peaks, (if clipping is desired), thus preventing overmodulation while allowing a more powerful side band to be transmitted. A cut-off filter attenuates all speech frequencies above 4000 cps.

The plate and the screen of the power amplifier tube are modulated by dual windings on the modulation transformer when using phone emission. When CW emission is employed, the power amplifier plate winding is short circuited and the filaments of the modulator tubes are turned off.

(2) SPEECH AMPLIFIER CIRCUITS. - Refer to figure 2-2. A 6SJ7 tube, pentode connected, is employed as a high gain voltage amplifier in the input stage of the speech amplifier. The 6SJ7 input tube is followed by a 6SN7 dual triode tube the first section of which precedes the 6H6 clipper tube. Refer to the schematic of the transmitter unit. The 6H6 clipper tube is shunted across the audio input to the second section of the 6SN7 audio amplifier tube. Notice that the cathode of one section of the 6H6 tube (pin number 4) is operating at a small fixed value of positive potential by virtue of being connected through reactor L301, resistor R310 to a tap on the cathode resistors R311, R312, and R313. This positive cathode potential biases the corresponding diode plate and no current flows through this section of the tube. However, when the magnitude of the negative audio peaks applied to the diode cathode become large enough to overcome the fixed positive potential, current flows through this section of the diode and the negative audio peak is attenuated by the short circuiting action of the diode. Likewise, the cathode of the second section of the clipper tube is returned to a tap on the 6SN7 amplifier cathode resistor which is more positive than the tap where its corresponding plate is attached. Thus the plate of the second section of the 6H6 is more negative than the cathode and no current flows. When a positive audio peak of sufficient magnitude reaches this diode plate the fixed negative bias is overcome and current flows through the second section of the diode and the positive audio peak is attenuated. Because of the above action the audio output of the second section of the audio amplifier tube cannot rise above the fixed level. Therefore, it is possible to set the degree of modulation with the Clipper Control R315 and be assured that the percentage of modulation will not rise above the chosen amount.

The output from the second section of the type 6SN7 dual triode tube is coupled to the grid of the modulator driver tube, V304 through capacitor C310 and the Clipper Control R315. V304, a type 6B4G power amplifier tube, drives

THEORY OF OPERATION

the grids of the Class "B" modulator tubes through coupling transformer T301.

(3) MODULATOR CIRCUIT. - A pair of Type 75TH triode power amplifier tubes are employed as modulators operating in Class B service. Excitation for the modulator grids is received from the driver tube through the driver transformer T301. Both the screen and the plate of the r-f power amplifier tube are modulated by individual secondary windings on the modulation transformer T302. When switching to CW emission, the modulator filaments are turned off and the power amplifier plate winding in the modulation transformer is short circuited.

Plate voltage for the audio amplifier and driver stages is obtained from the low voltage supply while plate voltage for the modulator tubes is obtained from the high voltage supply. Screen voltage for the power amplifier tube is also taken from the low voltage supply. Grid bias for all audio tubes except the modulators is obtained from cathode resistors. The modulators are biased by voltage from the bias supply. A variable resistor, R401, located at the rear of the low voltage power supply unit, is used for adjustment of the modulator bias.

e. METERING CIRCUITS. - All important circuits are metered in the transmitter unit. The power amplifier grid and plate currents, the modulator plate current, and the modulator/power amplifier filament voltage are metered. Two 3 ampere radio frequency meters to read r-f line current are mounted externally on the roof of the transmitter cabinet to be connected as desired.

f. ANTENNA TERMINATION. - Refer to figure 3-3. The antenna tuning unit incorporated in the 30K transmitter is a condenser - coil combination which can be conveniently changed from a series to a parallel tuned circuit. The inductance of the coil and the place of antenna feeder attachment can be changed at will, with the result that practically any type of antenna or antenna feeders can be employed. In order to cover the entire frequency range of the transmitter, two sets of plug-in coils are used. One set covers the 10, 11, 15 and 20 meter bands while the other set is used on the 40 and 80 meter bands. The coil units plug into a jack strip mounted on top of the antenna tuning condenser. The antenna coils are split and a moveable link inserted between the sections. This link is actually a continuation of the power amplifier plate tank coil. The connection between the two sections of the antenna coil is actually a small jumper which, when opened, places the antenna tuning capacitor in series with the antenna coil thus making it possible to tune extremely low impedance antennas or transmission lines. When this jumper is closed, the tuning capacitor is in parallel with the coil and high impedance antennas and transmission lines can then be tuned.

In addition to the features already mentioned, it is possible to connect the feed lines to any turn on the antenna coils by means of small contactor arms with which each coil is provided. This allows for perfect transmission line impedance matching.

SECTION 3

INSTALLATION AND INITIAL ADJUSTMENT

1. INSTALLATION.

a. PRELIMINARY.

(1) UNPACKING. - Refer to figure 1-1. The Model 30K transmitting equipment is packed in a number of wooden packing cases. Refer to the LIST OF MAJOR UNITS in Section 1 of this book and to the packing slip for a list of all the units supplied. Open packing crates with a nail puller rather than a bar or a hammer to prevent accidental damage to the units within. Remove the packing material and carefully lift the units out of the cases. Search all of the packing material for small packages. Inspect each unit for loose screws and bolts. Be certain all controls such as switches, dials, etc., work properly. All claims for damage should be filed promptly with the transportation company. If a claim for damage is to be filed, the original packing case and material must be preserved.

b. INSTALLATION PROCEDURE.

(1) PLACING THE CABINETS. - Each owner of the Collins Model 30K transmitting equipment will have his own individual placement problem and extensive thought and study should go into the proper placement of these units in order to get maximum efficiency from the equipment and also realize the operating advantages of the equipment. When choosing a location, consideration should be given to convenience of power, antenna, and ground connections, placement of remote cables and to maintenance.

As all the units are placed in the 30K cabinet from the rear, sufficient clearance should be allowed for a workman between the cabinet and any obstruction. In addition, sufficient clearance should be provided to allow for the rear door to swing back full out of the way. Refer to figure 3-1 for outline dimensions and clearances.

The Model 310A Exciter unit should be located on the operating table which should be within convenient arms reach of the Model 30K transmitter unit if advantage is to be taken of the variable frequency feature of the equipment. See figure 3-2.

(2) INSTALLATION OF UNITS. - Reference to the photographic illustrations will assist in the assembly of the transmitter. See figure 3-3. Any cords designed to hold the cable in place for shipment should be untied and removed. Place the heavy plate power transformer onto the bottom of the cabinet and make the connections indicated by the white tags tied to the cable lugs. After this, the power transformer may be placed over the mounting holes and bolted into place if desired. Proceed with the placement of units from the bottom to

INSTALLATION AND INITIAL ADJUSTMENT

the top. The tabulation below lists the various units of the transmitter. For purposes of identification the unit letter designation which appears on schematic diagram is also shown.

<u>Unit Letter Designation</u>	<u>Description</u>
A	Meter Panel
B	RF Power Amp Tube and Tank Circuits
C	Speech Amp and Mod
D	Low Voltage and Bias Power Supply
E	High Voltage Rectifier
F	Control Panel.
G	High Voltage Power Transformer
H	Terminal Bracket

Each unit should be placed with protruding control shafts properly centered to prevent binding and then bolted in place with bolts provided for the purpose. A set of Bristo wrenches is attached to the rear door to be used in tightening control knob set screws.

The meter panel should be in place and connections made before the coil mounting plate of unit "B" is bolted to the ceramic stand-offs.

(3) INTERNAL CONNECTIONS. - The connections between the units of the 30K are made by a preformed cable. The cable leads are formed and laced tightly so that they have a natural tendency to seek the proper terminal. Each wire is color coded and otherwise identified on the schematic drawing by means of the unit letter and terminal number to which the wire should be terminated. Each cable connection in the transmitter is marked by a tag when the transmitter is dismantled for shipment. The cable connections can therefore be properly installed by following the markings on the tags.

The order of designation of inter-unit cabling is as follows: When a wire terminates on a single numbered terminal on a unit, the wire route is from the source to the terminal on the specified unit and is indicated by the unit letter designation followed by the terminal number. Thus, if a wire emanating

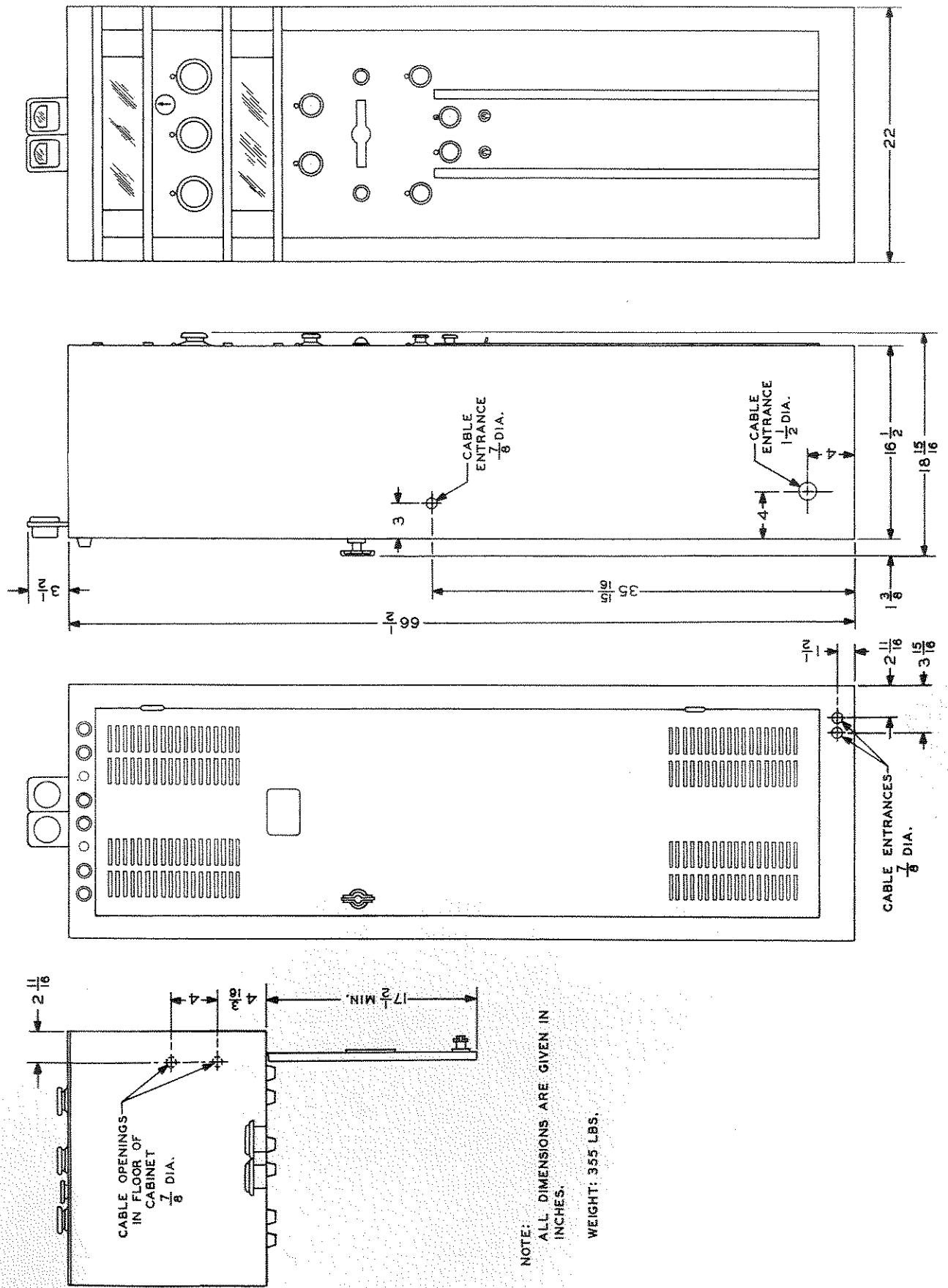

Figure 3-1 Transmitter Outline and Mounting Dimensions

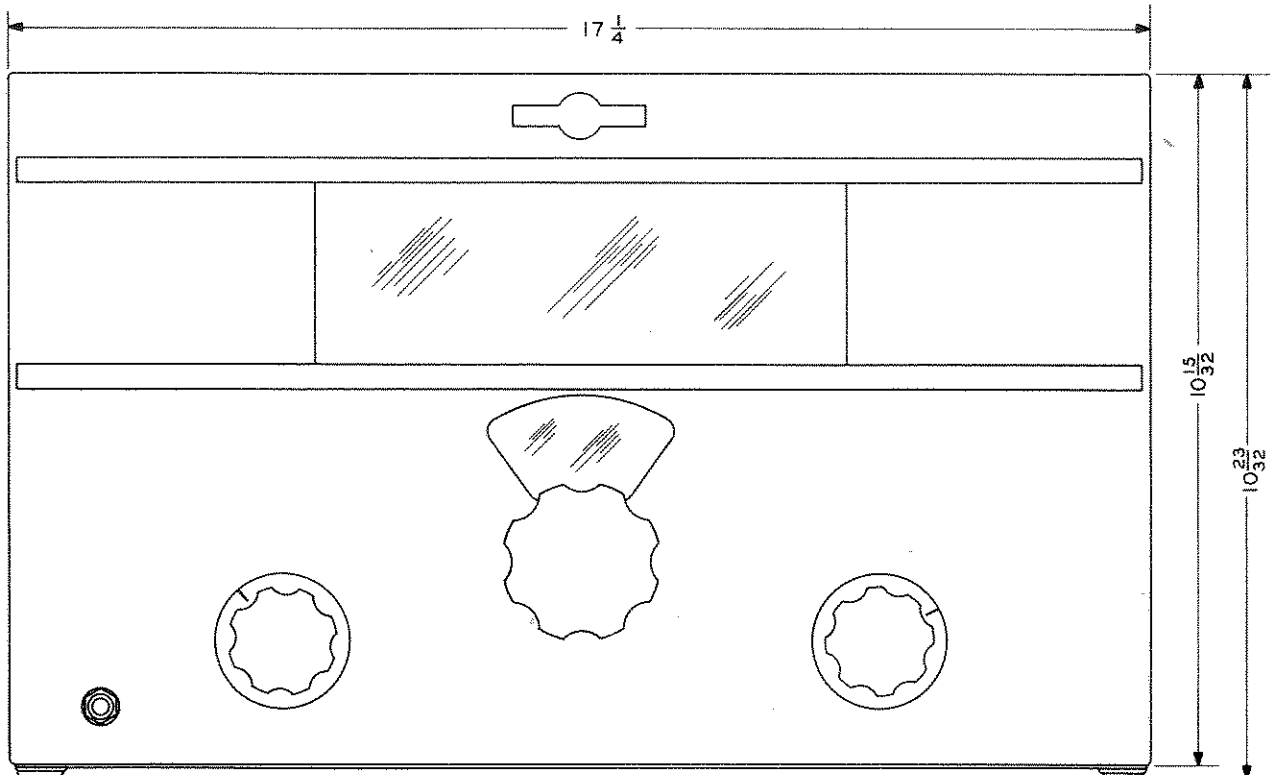
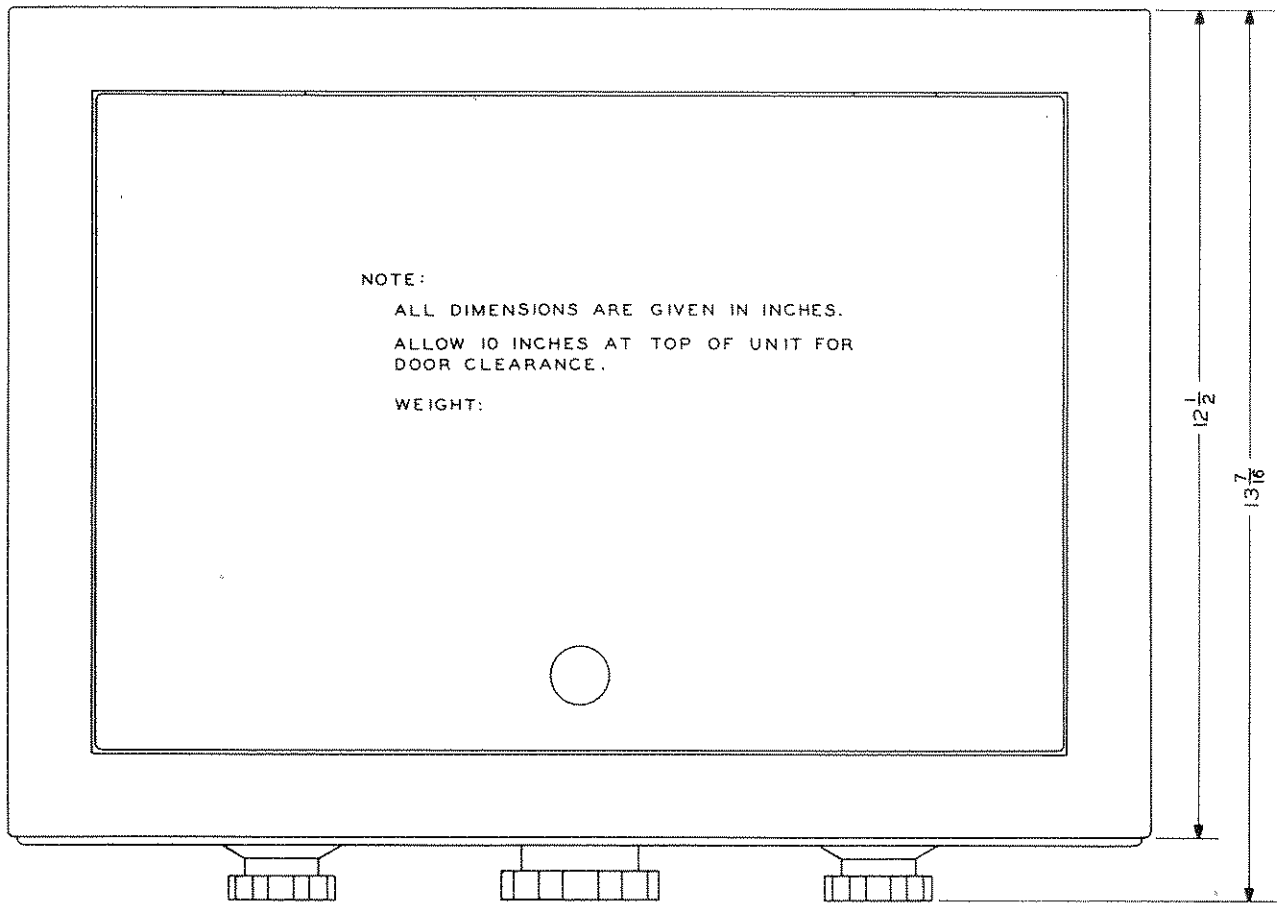

Figure 3-2 Exciter Outline Dimensions

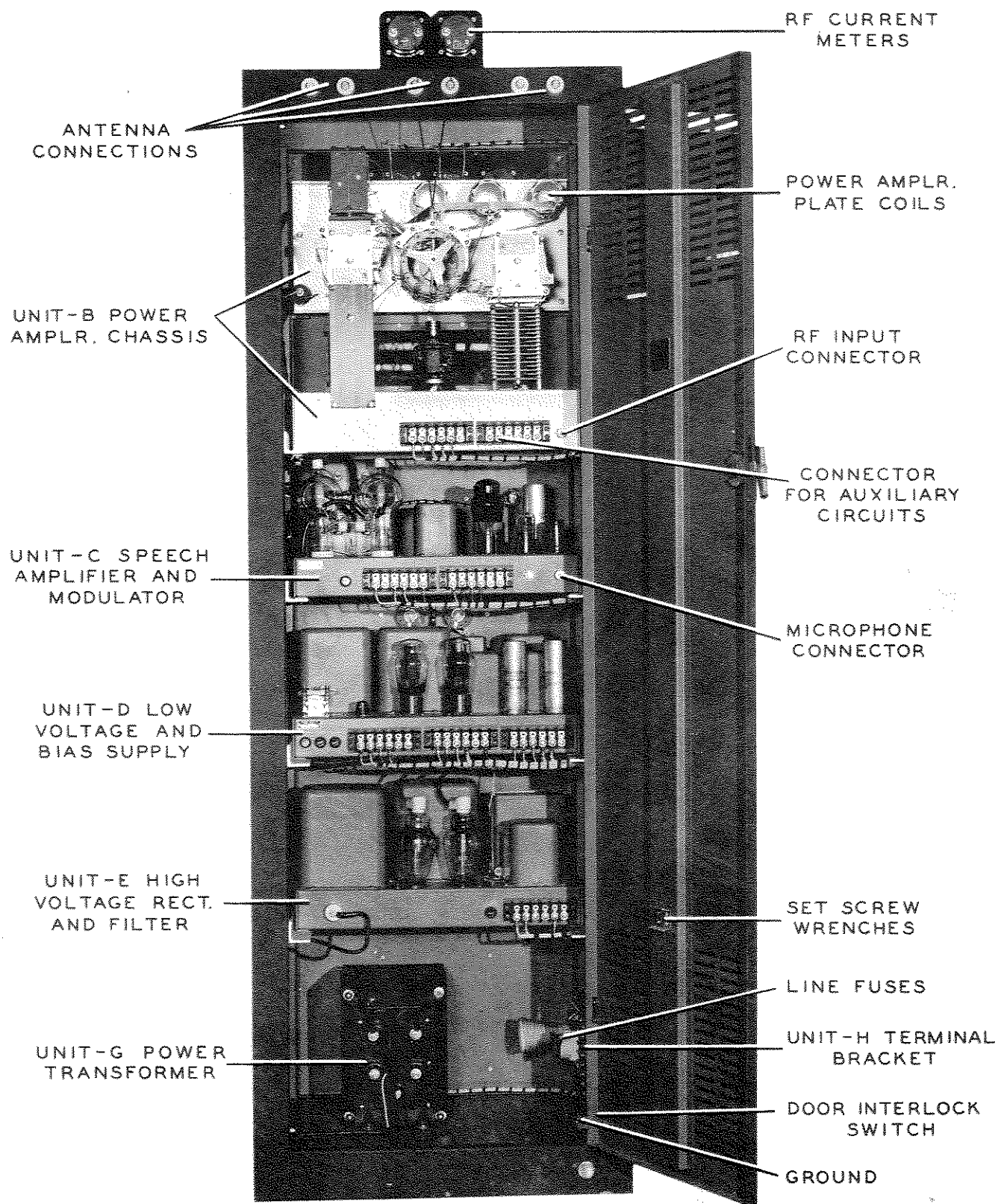

FIGURE 3-3 TRANSMITTER - REAR OPEN

INSTALLATION AND INITIAL ADJUSTMENT

from terminal number 2 on unit A is to be connected to terminal number 12 on Unit C, an arrow at terminal number 2 on unit A would indicate C12 and a similar arrow at terminal 12 on unit C would indicate A2.

Color coding of wires is used to facilitate connecting cables to terminal strips. The code is indicated by a letter such as A, B, etc., followed by a figure such as 1, 3, 5, etc. The letter designates the wire structure, size, amount and kind of insulation and rating. The figures refer to RMA color code for resistors etc. A Class A Wire with solid red covering would be an A2 wire while a Class A tracer wire with a red body and a white tracer would be designated A29.

(4) FUSES. - All fuses should be examined and their ratings checked. Refer to the MAINTENANCE section of this book for a table of fuses.

(5) EXTERNAL CONNECTIONS. - Place all POWER switches in the OFF position before attempting to make any external connections. The external connections for the Model 30K transmitter consist of the following:

- AC power line
- Control and Audio
- Exciter output
- Radiation system
- Utility

(a) AC POWER LINE. - The 30K is designed to operate from a 115 volt, single phase, 60 cycle power source. The supply line voltage and frequency should be checked before connections are made. The maximum load taken by this equipment is 1350 watts. A power line of at least 2 k. v. a. capacity should be installed for each transmitter installation. Connect the power line directly to the bottom terminals of the line fuse block in the bottom of the cabinet. Number 10 or larger, suitably insulated wire, should be used. The "high" side of the line should be connected to terminal #15, if possible. The "high" side of the line may be found by checking with a small 110 volt bulb from each side of the line to an external ground. It is recommended that an external wall mounting, two pole, disconnect switch be installed between the transmitter and the main line connections. If line voltage is more than 5 volts too low or too high, the installation of an autotransformer is advisable. If 220 volts is available, a step down autotransformer may be used.

Two holes 7/8" in diameter are available in the base of the cabinet for power leads, if a power conduit channel is used; otherwise the power leads may enter the cabinet through the holes in the rear of the base and thence through the above mentioned holes to the terminal board. Refer to figure 3-1

INSTALLATION AND INITIAL ADJUSTMENT

for location of the power entry holes. A 1-1/2 inch hole drilled in the side of the cabinet at base level is also available for power lead entry.

(b) CONTROL AND AUDIO. - A 25 foot length of five-conductor cable is provided for connection between the 310A Exciter unit and the 30K Transmitter unit. The white, red, black and green rubber covered wires may be connected as desired, however, the white flame-proof wire is the outer shield for the cable and should definitely be used as the ground interconnection.

The two units are connected together as follows:

<u>*30K Terminal Number</u>		<u>310A Exciter Terminal Number</u>
1.	connect to	GND
2.	"	9
3.	"	12
4.	"	11
5.	"	10

Jumper terminal #8 to the gnd stud on the 310A Exciter.

Control cable connections to the Exciter unit are made through a cut-out in the rear of the exciter cabinet. The control cable may enter the transmitter cabinet through the side of the transmitter cabinet.

The telegraph key may be plugged into a key jack in the front of the exciter unit or connected from terminal number 7 to gnd stud at the rear of the exciter unit; in which case, the key jack wire, connected to terminal 7, must be removed.

The microphone connection is made to the speech amplifier and modulator chassis by means of an amphenol single connector microphone receptacle. This receptacle is located at the rear of the chassis and the microphone cable may enter the cabinet at the same place as the control cable. It is very important, in avoiding feedback troubles, to tighten the ring on the microphone plug very securely. See figure 3-5 for a schematic on how to connect a microphone switch for push-to-talk operation. A 7/8" hole is drilled in the side of the cabinet near the audio input jack for microphone cable entry.

(c) EXCITER OUTPUT. - The exciter output is transmitted to the 30K Transmitter unit by means of a small concentric transmission line. Each end of the transmission line is equipped with a suitable connector. Use only the length of RF cable supplied. Do not cut it or use a longer cable as it may be difficult to secure proper drive on all bands.

* The 30K terminals in the bottom of the cabinet are numbered similar to the terminals at the rear of the other units. The numbers, however, are behind the terminals strips.

INSTALLATION AND INITIAL ADJUSTMENT

The transmitter end of this transmission line is connected to a receptacle at the rear of Unit B while the exciter end is connected to a receptacle at the rear of the exciter unit. Be sure both connectors are clamped in their respective receptacles tightly.

(d) RADIATION SYSTEM.

1. GENERAL. - This transmitter has antenna tuning facilities which will tune any kind of antenna or antenna transmission line. Two plug-in coil units are necessary for complete coverage. The coil unit with the single turn link is the proper unit for 10, 11, 15 and 20 meter operation while the other unit is intended for 40 and 80 meter use. Three sets of antenna terminals are mounted at the rear top edge of the cabinet to provide connections to several different antennas. The equipment is shipped with the various antenna selector contacts on the PA band switch connected together and then connected to the center pair of antenna terminals. If more than one antenna is available, the jumpers should be removed from the band switch and reconnected to provide for the extra antennas. The following instructions will enable one to connect the antenna tuner for operation with any of the popular antennas found at amateur stations.

2. UNTUNED HIGH IMPEDANCE TRANSMISSION LINE. - If the line has a characteristic impedance value of 50 ohms or over, parallel tuning of the antenna coil should be employed. For parallel tuning, the little jumper seen underneath the antenna coil should be closed. The tuning capacitor tap arms should be approximately as indicated in table I and the transmission line tap arms should be set on the same turn as the capacitor tap arms. The transmission line tap arms are those which are nearest the cabinet wall. In this type of operation, low values of capacitance and high values of inductance are best.

3. UNTUNED LOW IMPEDANCE TRANSMISSION LINES. - Transmission lines having a characteristic impedance of less than 50 ohms require series tuning of the antenna coil. This is done by opening the small jumper underneath the coil and moving the transmission line tap arms to the inside coil turns. The capacitor coil tap arms should be set approximately as shown in table I to start. In this type of operation, high values of capacitance and low values of inductance are preferred.

4. VOLTAGE FED TUNED TRANSMISSION LINES. - Transmission lines which have a current node at the transmitter should be connected exactly like the high impedance untuned transmission lines are connected. See paragraph 2, above. It is highly recommended that tuned transmission lines be cut to multiples of a quarter wave in length.

INSTALLATION AND INITIAL ADJUSTMENT

5. CURRENT FED TUNED TRANSMISSION LINES. - Transmission lines which have voltage nodes at the transmitter should be connected exactly like the low impedance transmission lines are connected. See paragraph 3, above. These lines should also be cut to multiples of a quarter wave in length for best results.

6. QUARTER WAVE MARCONI. - Series tuning is indicated for the quarter wave Marconi antenna. In this type of operation the antenna tuning circuit should be connected so that the two sections of the antenna coil and one half of the antenna tuning capacitor are in series. To do this, place a grounding jumper to the rotor of the antenna tuning capacitor, connect the antenna to one end of the antenna coil, connect one stator section of the antenna tuning capacitor to the other end of the antenna coil and disconnect the other stator completely (slide contactor arm off wire). Refer to figure 3-4.

7. END FED HALF WAVE. - End fed half wave (or even multiple of a half wave) antennas can be excited by employing parallel tuning. In this type of operation, the antenna is connected to one antenna terminal while the other antenna terminal is connected to transmitter ground. The little jumper under the tuning coil should be closed and the transmission line tap arm connected to the grounded antenna terminal should be moved to the inside coil turn. The corresponding tuning capacitor tap arm should be moved to the turn indicated in the table for untuned high impedance transmission lines. The other capacitor tap arm should also be set at the position indicated in the table for high impedance transmission lines and the transmission line tap to which the antenna is attached should be set on this same turn.

8. GROUND. - A good ground should be connected to the large stud in unit H (bottom of the cabinet) to reduce possibilities of r-f feedback.

(e) UTILITY CONNECTIONS.

1. ANTENNA RELAYS. - An extra switch section is placed on the power amplifier grid band switch for automatically operating antenna relays or other control relays. The switch points are brought out to terminals marked 7, 8, 9, 10, 11 and 12 at the rear of unit B. Terminal #7 is the common terminal of the group.

Terminals 11 and 12 of unit H are connected to 115 volts a.c. for use in exciting the coil of an external relay. These terminals are in parallel with the HV transformer primary and therefore are energized when the transmitter is emitting a signal. See figure 3-5 for possible uses of external relays connected to terminals #11 and 12 of unit H.

(f) EXTERNAL POWER CONNECTIONS. - Terminals 7 and 8 of unit H are connected to -60 v d.c. and +500 v d.c. respectively for possible use with external equipment.

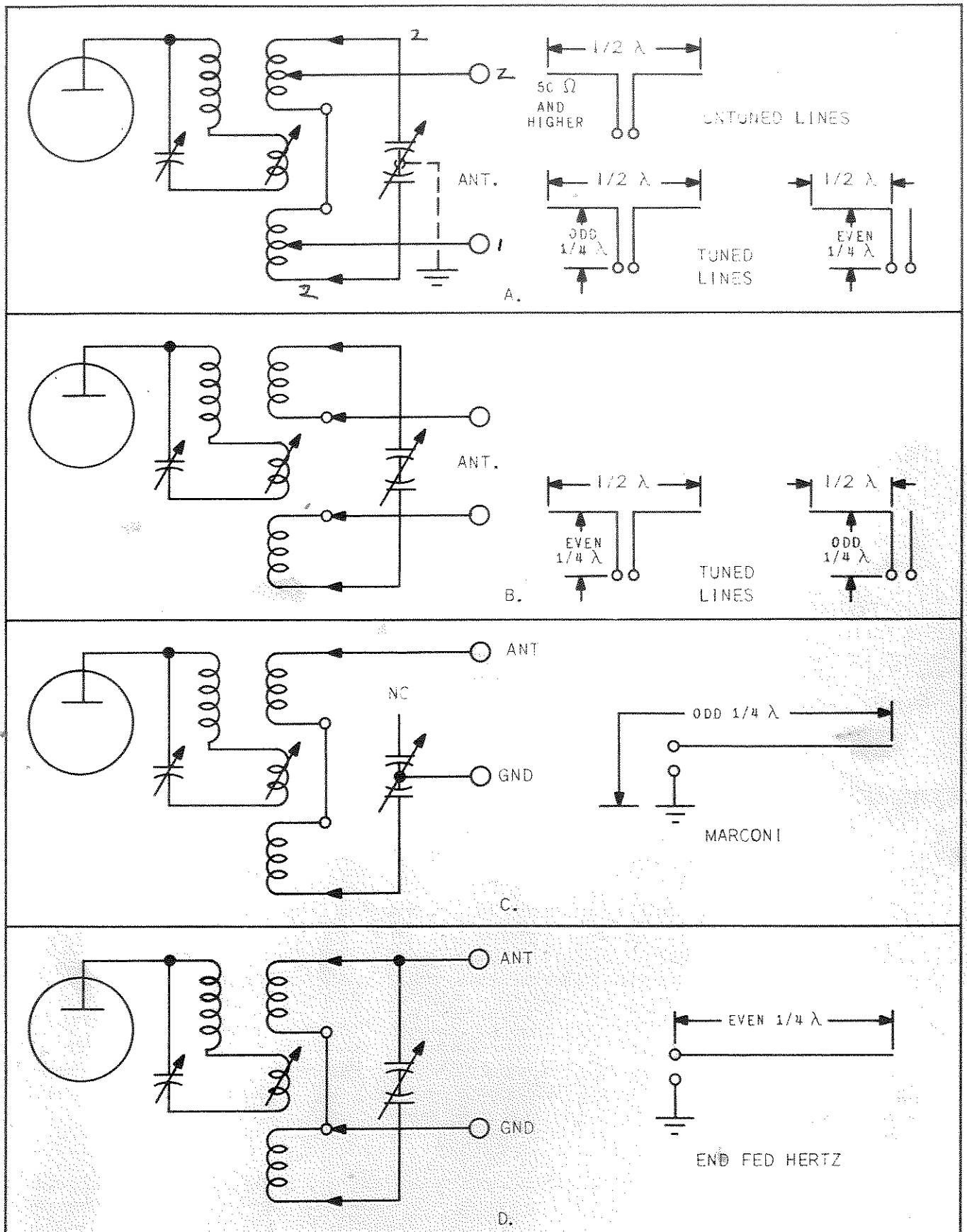
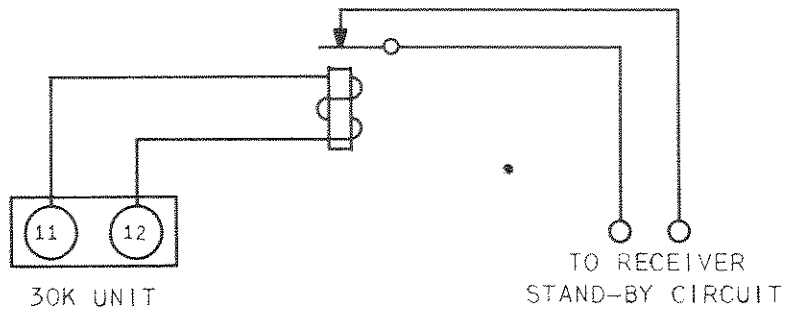
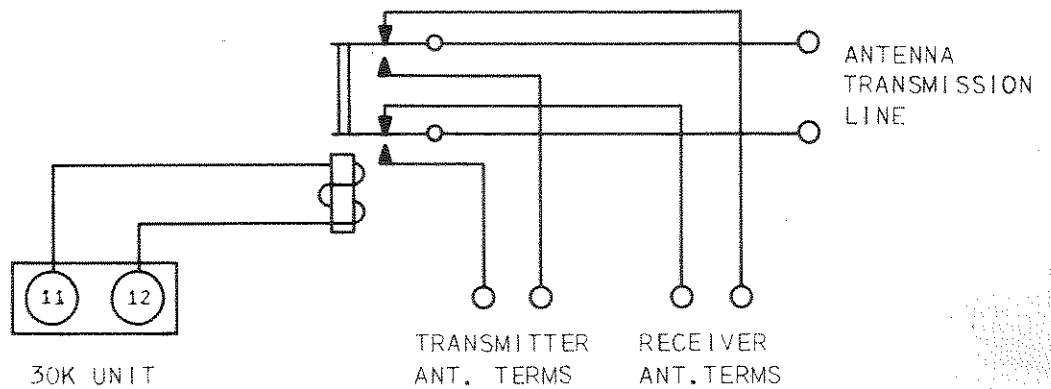

Figure 3-4 Applicable Antenna Tuning Circuits

A. RECEIVER STAND-BY WITH EXTERNAL RELAY.



B. ANTENNA CHANGE OVER WITH EXTERNAL RELAY.



C. PUSH TO TALK USING MICROPHONE SWITCH.

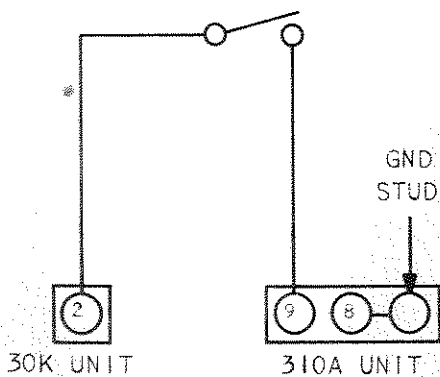

D. ANTENNA SELECTION USING EXTERNAL RELAYS.

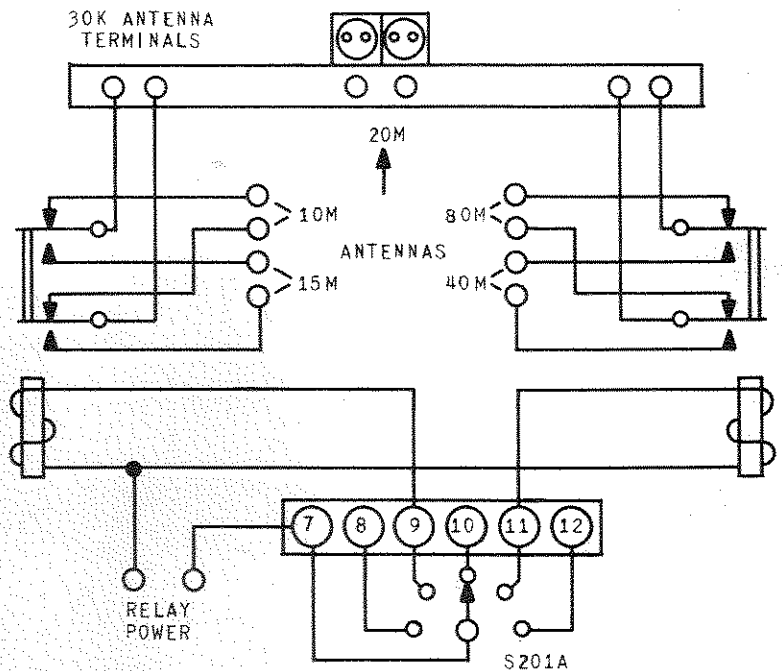

Figure 3-5 Possible Auxiliary Circuits

INSTALLATION AND INITIAL ADJUSTMENT

(g) RECEIVER STD-BY. - Terminals number 5 and 6 at the rear of the 310A exciter unit are connected to a switch section on the exciter POWER switch and may be used to turn the receiver on and off for stand-by purposes. As connected at the factory, the receiver would be turned on in every position of the exciter POWER switch excepting the SEND position. If other means of receiver stand-by are employed, this switch could be used to turn a cw or phone monitor on or for some other useful purpose.

(h) METER CONNECTIONS. - In order to facilitate alignment of the exciter during servicing, two sets of terminals have been provided at the rear of the exciter unit for inserting meters to read 807 doubler grid and plate currents. While these meters are only necessary during re-alignment of the exciter, the user may, if desired, place meters in these circuits permanently. A 10 ma meter for grid current and a 150 ma meter for plate current is recommended.

2. INITIAL ADJUSTMENTS.

a. GENERAL. - The initial adjustments consist of selecting the operating frequency, tuning the power amplifier to the operating frequency, loading the antenna, and adjusting the speech system. After all internal and external connections have been made and inspected and the tubes and fuses have been inserted in the proper sockets, the 115 volt 60 cps power may be applied. Be sure all power switches are in the OFF position.

b. FILAMENT VOLTAGE. - The value of filament voltage on the power amplifier and modulator tubes (5.0 volts a.c.) is rather critical, therefore, a front panel manual adjustment is included on the 30K unit to compensate for varying power amplifier and modulator tube filament voltages.

The filaments in the exciter tubes may be turned on by operating the exciter POWER switch to the RECEIVE position providing the FILAMENT power switch on the 30K unit is in the ON position. The filaments in the 30K unit may be turned ON by operating the FILAMENT switch to the ON position. When turning the 30K filaments on for the first time, the filaments of the 866A rectifiers should be allowed to operate for 15 minutes before applying plate power to the rectifiers. Thereafter only 30 seconds will be required.

c. ADJUSTMENT PROCEDURE.

(1) EXCITER UNIT.

(a) Place the FILAMENT power switch in the 30K unit on the ON position. Be sure the PLATE POWER switch is in the OFF position.

INSTALLATION AND INITIAL ADJUSTMENT

(b) Rotate the EXCITER CONTROL switch to the REC position. (Allow 30 seconds for the tubes to heat.)

(c) Choose the operating band with the BAND switch and close the telegraph key.

(d) Rotate the TUNING Control to the desired frequency and check in a receiver to see if the channel is clear.

(e) Operate the EXCITER CONTROL switch to the SEND position.

(2) 30K TRANSMITTER UNIT.

(a) Be sure the PLATE power switch is in the OFF position and the AUDIO control is in the "0" position.

(b) Insert the proper antenna tuning coil. Use the coil with the single turn link for 10, 11, 15 and 20 meters. Use the coil with the 6 turn link for 40 and 80 meters.

(c) Operate the PHONE-CW switch to the CW position.

(d) Operate the PA GRID and PA PLATE BAND switches to the band that includes the frequency selected under (d) above.

(e) Place the LV-TUNE-OPERATE switch in the LV position.

(f) Operate the ANTENNA COUPLING control to the counterclockwise position.

(g) Operate the PLATE POWER switch to the ON position.

(h) Tune the PA GRID Control for maximum PA GRID CURRENT. A value of at least 12 - 15 ma should be obtained.

(i) Operate the LV-TUNE-OPERATE switch to the TUNE position and tune the PA PLATE tuning control to PA PLATE CURRENT dip or minimum.

(j) Place the TUNE-OPERATE switch in the OPERATE position.

(k) Tune the antenna and load the transmitter as outlined in paragraph (3) below.

(1) Re-check the PA PLATE TUNING control for exact resonance. (Normal color of PA tube plate is from dull to cherry.)

INSTALLATION AND INITIAL ADJUSTMENT

(m) Check the FILAMENT VOLTAGE and adjust the FILAMENT ADJUSTMENT until 5 volts is obtained. Be sure to turn the PLATE power OFF while changing the FILAMENT ADJUSTMENT tap switch.

(3) ANTENNA TUNING AND LOADING. - Having completed steps (a) to (j) in paragraph g. (2) above, the antenna can be tuned and the transmitter loaded by the following method. Refer to paragraph l. b. (5) (d) RADIATION SYSTEM for connections for various types of antennas and transmission lines.

(a) PARALLEL TUNING. - (High impedance untuned lines and voltage fed tuned lines.) Be sure the small jumper under the antenna coil is closed and the feeder switch arms are on the same turns on which the capacitor tap arms are set. The capacitor switch arms should be set on the turns so designated in table I for the operating frequency.

1. Rotate the ANTENNA TUNING Control until antenna resonance is indicated by maximum antenna current.

2. Rotate the ANTENNA COUPLING Control clockwise until a reading of 200 ma is obtained on the PA PLATE meter. (If it is impossible to get 200 ma reading, turn the plate power off and rotate each transmission line tap arm on the antenna coil towards the center of the coil one turn at a time until this reading is possible. Use the turns which allow tightest coupling.)

NOTE

Fewer turns between antenna taps means increased loading.

In this type of operation, large amounts of inductance and low values of capacitance in the antenna tuning circuit is desirable.

(b) SERIES TUNING. - (Low impedance, i.e., below 50 ohms, untuned lines and current fed tuned lines.) The small jumper under the antenna coil should be open and the transmission line tap arms should be on the inside turns of the antenna coils while the tuning capacitor tap arms should be as indicated in table I for the operating frequency. (This is merely a good starting position only.)

INSTALLATION AND INITIAL ADJUSTMENT

1. With the COUPLING Control at the extreme counterclockwise position, turn the ANTENNA TUNING control until resonance is indicated by the antenna current meters.

2. If the ANTENNA TUNING Control is positioned with the capacitor plates nearly closed, turn the ANTENNA COUPLING Control clockwise until 200 ma is obtained on the PA PLATE meter.

3. If it is impossible to load the power amplifier to 200 ma or the antenna tuning capacitor is in the low capacity portion of the dial, turn the plate power off and move the tuning capacitor tap arms toward the center of the antenna coils and repeat the tuning procedure.

NOTE

In this type of operation, large values of capacity and small amounts of inductance are desirable in the antenna tuning circuit.

(c) MARCONI ANTENNA. - In general, tuning instructions indicated for SERIES TUNING, paragraph (b) above, apply. Remember that large values of circulating current are possible so means should be taken to prevent damage to the r-f meters.

(d) END FED ANTENNAS. - Any antenna that is even multiples of a quarter wave long can be end fed with a parallel tuned circuit. The tuning instructions for this type of operation are the same as for PARALLEL TUNING, paragraph (a), above. See paragraph 1. b. (5) (d) RADIATION SYSTEM for antenna circuit connections.

(e) ANTENNA TUNING NOTES.

1. When using tuned transmission lines, better results can be obtained from lines which are very nearly a multiple of a quarter wave in length; otherwise high values of reactance might be present which will necessitate additional reactive elements of opposite sign placed across the transmission line before the line can be made to take proper loading.

2. The rotor of the antenna tuning capacitor can be grounded for harmonic suppression by placing a jumper across the bakelite rear support of the capacitor, providing a well balanced antenna is used.

(4) CW OPERATION. - For CW operation in the PHONE-CW switch should be in the CW position and the key plugged into the KEY jack on the front panel of the exciter unit. See paragraph 1 a. (5) (b) in the INSTALLATION section of this book.

INSTALLATION AND INITIAL ADJUSTMENT

The AUDIO gain control should be in the "0" position; PA PLATE CURRENT should be 200 ma.

(5) PHONE OPERATION.

(a) TUNING ADJUSTMENTS. - The tuning operations are identical to those outlined in paragraph c. (2), except that the PA should be loaded to 150 ma in step c. (2) (k).

The PHONE-CW switch should be in the PHONE position and the telegraph key shorted.

The modulator tubes static plate current (no modulation) should be adjusted to 45 ma by rotating the MODULATOR BIAS control at the rear of unit C with the transmitter fully operating. This will have to be done by steps since opening the rear door opens the interlock switch and turns the plate power off.

CAUTION

Do not operate the PHONE-CW switch while the plate power is ON. Always turn the PLATE POWER switch to the OFF position before operating the PHONE-CW switch.

(b) AUDIO ADJUSTMENTS.

(1) SPEECH CLIPPER OUT. - The percentage of modulation at which speech clipping occurs has been chosen as 100% and the modulation control locked at the factory. If speech clipping is not desired, merely adjust the AUDIO GAIN Control on the front panel until approximately 150 ma MODULATOR PLATE current is obtainable on heavy modulation peaks.

In event speech clipping is to be dispensed with entirely, the 6H6 Clipper tube can be removed from its socket in the modulator unit. No harm can result other than the possibility of overmodulation.

(2) SPEECH CLIPPER IN. - This adjustment should be made using an oscilloscope to observe percentage of modulation. The oscilloscope should be coupled to show PA r-f envelope after which the control at the rear of Unit C should be advanced to about the mid point. This control is used to set the percentage of modulation at which clipping occurs. Proceed to talk into the microphone and advance the AUDIO gain control on the transmitter panel until peak clipping is observed on the oscilloscope screen. The percentage of modulation can now be set with the control at the rear of Unit C.

Once the percentage of modulation has been set, the value of speech clipping can be adjusted by the AUDIO gain control. With the control in an

INSTALLATION AND INITIAL ADJUSTMENT

advanced position, a greater amount of sideband power is obtained because of the higher modulation average. With the control set thus, however, a quiet operating position is desirable because of the higher audio gain with resultant higher room noise.

NOTE

Since clipping over 6 db results in less desirable quality, even though the intelligibility may be better for working through interference, the signal should be monitored and the audio gain adjusted to the point which produces a balance between more audio power and good quality.

(6) CALIBRATE.

(a) GENERAL. - The CALIBRATE position on the Exciter Control Switch is provided to enable the operator to set the transmitter frequency on a clear channel within the amateur band. In the CAL position, the Exciter Control Switch turns on the plate power to all of the tubes in the exciter and connects a high value of cathode resistor in the 807 doubler stage. The signal thus produced is weak and can be tuned in on the communications receiver. If the signal is too weak, a small pick up antenna, connected to the receiver, can be placed near the Exciter Unit.

TABLE I

ANTENNA TUNING CHART FOR 300 OHM RESISTIVE LOAD

Band	Antenna connection Tap	Antenna Tuning Capacitor Tap
10	*1-1/2 turns total	*3 turns total
15	2 turns each side of center	3 turns each side of center
20	2 turns each side of center	5 turns each side of center
40	5 turns each side of center	13 turns each side of center
80	5 turns each side of center	Entire coil

* Divided as equally each side of center as possible.

1. Parallel tuning should be used with this table.
2. Except where designated with the asterick (*) count each wire as a full turn even though it actually is a part of a turn or a full turn and a fraction.
3. This table is for 300 ohm resistive load; for other loads the settings will differ somewhat. Higher impedance lines require more turns from center for antenna connection taps, likewise, lower impedance lines require fewer turns from center.
4. This table isn't suitable for lines below 50 ohms impedance which require series tuning of the antenna coil.

INSTALLATION AND INITIAL ADJUSTMENT

NOTE

The clipper level adjustment at the rear of the speech unit is set at the factory using the following procedure.

The transmitter is loaded for normal power input and a 400 cycle sine wave audio tone fed into the microphone input. The clipper control should be set at approximately 1/5 turn back from the full clockwise position. Advance the audio gain control (front panel) until approximately 75% modulation is obtained on an oscilloscope observing the modulated wave form. Increase the audio input 12 db. Adjust the clipper control so that just 100% modulation is reached. Repeat if necessary so 12 db increase in audio level raises modulation to just under 100%.

NOTE

In event objectionable key clicks or thumps are encountered, the circuit shown below can be used very effectively in eliminating same without seriously altering the character of the keying. RFC is a 2 mh radio frequency choke while the 15 hy choke shown is an ordinary AC-DC receiver type filter choke. Both can be of approximately 50 ma rating. The .5 mfd capacitor can be rated at 400 WV.

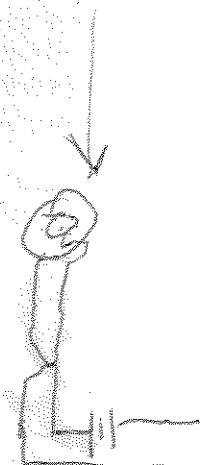
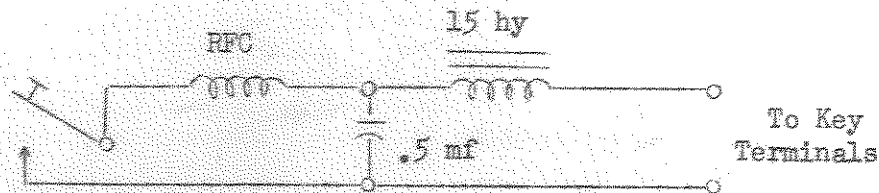

SECTION 4

OPERATION

1. STARTING THE EQUIPMENT.

a. PROCEDURE. (Be sure PA PLATE POWER switch is in OFF position).

- (1) Operate FILAMENT switch to ON position. (Allow 30 seconds for filaments to heat.)
- (2) Operate the EXCITER CONTROL SWITCH to REC. position.
- (3) Select the type of emission with the PHONE-CW switch.
- (4) Operate the transmitter PLATE switch to the ON position.
- (5) Proceed to control the emission with the EXCITER CONTROL SWITCH and the key.

2. STOPPING THE EQUIPMENT.

a. PROCEDURE.

(1) EMERGENCY

- (a) Operate the FILAMENT switch to OFF.
- (b) Open station main power switch.

(2) ROUTINE.

- (a) Operate the EXCITER CONTROL SWITCH to the RECEIVE position.
- (b) Operate the Transmitter PLATE power switch to the OFF position.
- (c) Operate the FILAMENT switch to the OFF position.

3. GENERAL.

a. FUNCTIONS OF THE EQUIPMENT.

(1) TYPES OF EMISSION. - Voice or Continuous Wave.

- ##### (2) FREQUENCY RANGE. -
- 3.5 to 4.0 mc
 - 7.0 to 7.3 mc
 - 14.0 to 14.4 mc
 - *21.0 to 21.5 mc
 - 28.0 to 30.0 mc

*This band is unauthorized at this date. (3-5-47)

OPERATION

(3) POWER INPUT. - VOICE = 375 watts
CW = 500 watts

(4) FREQUENCY CONTROL. - Stabilized master oscillator.

(5) POWER SOURCE. - 115 volts 60 cps.

(6) POWER CONSUMPTION (MAX). - 1270 watts.

(7) MICROPHONE. - Any high impedance microphone. (Crystal or high impedance dynamic).

b. OPERATING PRECAUTIONS.

(1) Operate all tube filament within ± 5 percent of published ratings.

(2) Allow 30 seconds for tubes to warm up upon turning transmitter on after any appreciable shut-down period.

(3) Do not operate power amplifier stage off resonance except in TUNE position.

(4) Always place the PLATE power switch in the OFF position when operating the PHONE-CW Control or the FILAMENT ADJUSTMENT.

4. ROUTINE OPERATION.

a. PANEL CONTROL.

(1) STARTING THE EQUIPMENT.

(a) Operate the FILAMENT switch to the ON position. (Allow 30 seconds for tube filaments to warm up).

(b) Select type of emission with the PHONE-CW switch.

(c) Operate the EXCITER CONTROL SWITCH to the RECEIVE position. (Allow 30 seconds for tubes to warm up).

(d) Operate the transmitter PLATE power switch to the ON position.

(e) Operate the EXCITER CONTROL SWITCH to the SEND position and close telegraph key.

NOTE

Always place the TUNE-OPERATE switch in the TUNE position when tuning the power amplifier plate circuit to resonance. (Slight adjustments can be made in the OPERATE position. No harm will be done if the PA tube plate does not get too bright. Dull red to cherry red is proper in normal operation).

OPERATION

(2) STOPPING THE EQUIPMENT.

- (a) Operate the transmitter PLATE switch to the OFF position.
- (b) Operate the EXCITER CONTROL SWITCH to the OFF position.
- (c) Operate the transmitter FILAMENT switch to the OFF position.

b. REMOTE CONTROL.

(1) GENERAL. - It is intended that this equipment shall be normally controlled from the receiving position which may be at a position removed from the transmitter unit. The following procedure may be followed for operating the equipment at such a position. The transmitter must be tuned and in operating condition before the following operations are performed.

(2) STARTING THE EQUIPMENT.

- (a) Operate the transmitter FILAMENT switch to the ON position.
- (b) Select type of emission desired with the PHONE-CW switch.
- (c) Operate the PLATE power switch to the ON position.
- (d) Operate the EXCITER CONTROL SWITCH to the RECEIVE position.
(Allow 30 seconds for the tube filaments to warm up).
- (e) Operate the EXCITER CONTROL SWITCH to the SEND position to transmit and to the REC. position to receive.

(3) STOPPING THE EQUIPMENT.

- (a) Operate the EXCITER CONTROL SWITCH to the RECEIVE position.
- (b) Operate the PLATE power switch to the OFF position.
- (c) Operate the FILAMENT switch to the OFF position.

Steps (a) and (b) are performed in the interests of safety only. Actually, the equipment can be turned off with step (c) only.

5. TUNING INSTRUCTIONS.

a. EXCITER UNIT.

- (1) Place the EXCITER CONTROL SWITCH in the CALIBRATE position.

OPERATION

(2) Rotate the BAND switch to the band containing the desired operating frequency.

(3) Rotate the TUNING knob until the slide rule dial indicates the first two digits (if operating in the 7.0 mc band) or the first three digits (if operating in the 3.5, 14, 21, 27 or 28 mc bands). See figure 4-2.

(4) Continue rotating the TUNING knob until the vernier tuning dial indicates the last digits of the desired frequency.

(5) Check the frequency with a receiver to see that there has been no error in tuning the exciter. (With the EXCITER CONTROL SWITCH in the CAL position, listen to the exciter output with a receiver.)

NOTE

On the slide rule dial, each division equals 100 kc on all bands excepting the 80 meter band where each division equals 10 kc.

b. TRANSMITTER UNIT. - If the Exciter unit is tuned to frequency, the transmitter may now be tuned and adjusted. (Be sure the transmitter PLATE switch is in the OFF position and the LV-TUNE-OPERATE switch is in the LV position.)

(1) Operate the PA GRID band switch and the PA PLATE band switch to the bands which contain the desired operating frequency.

(2) Select the type of emission with the PHONE-CW selector switch and rotate the AUDIO GAIN control to the OFF position.

(3) Reduce the ANTENNA COUPLING to counterclockwise position.

(4) Place the EXCITER CONTROL SWITCH in the SEND position.

(5) Operate the PLATE power switch to the ON position.

(6) Rotate the PA GRID tuning control to the point of maximum grid current as shown on the PA GRID CURRENT meter. The grid current should be 12 to 15 milliamperes.

(7) Place the TUNE-OPERATE switch in the TUNE position and tune the PA PLATE TUNING control to resonance as indicated by minimum PA plate current.

(8) Advance the ANTENNA COUPLING a few degrees and tune the antenna tank condenser to resonance.

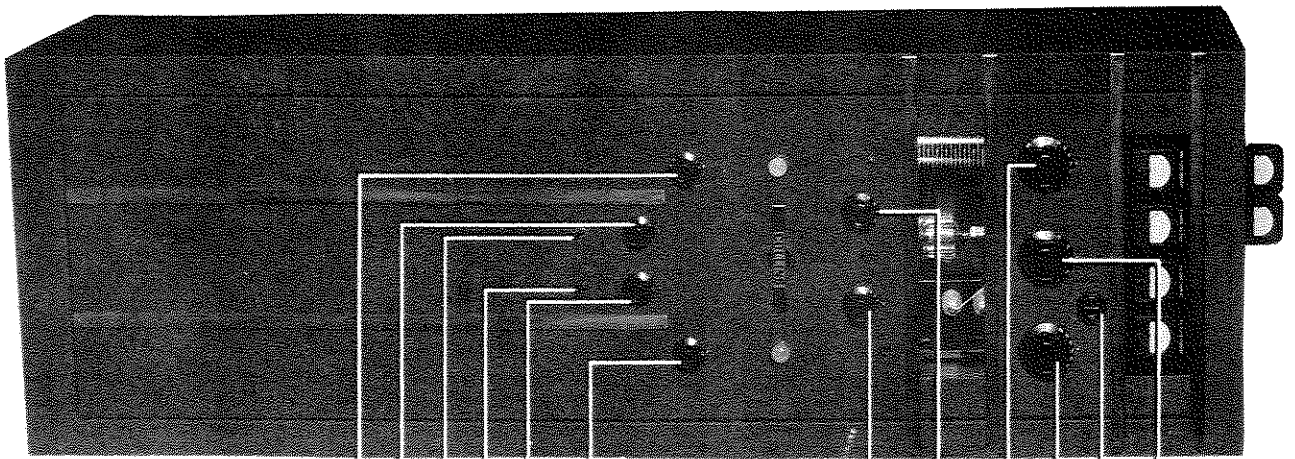

- PLATE BAND SWITCH
- ANTENNA COUPLING
- ANTENNA TUNING
- PA TUNING
- GRID BAND SWITCH
- PA GRID TUNING
- PHONE-CW SWITCH
- TUNE-OPERATE SWITCH
- PLATE POWER
- FILAMENT ADJUSTMENT
- AUDIO GAIN

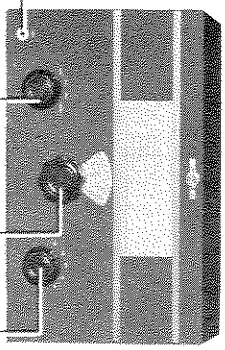

- KEY CONTROL SWITCH
- TUNING
- BAND SWITCH
- MODULATOR BIAS ADJUSTMENT
- CLIPPER CONTROL

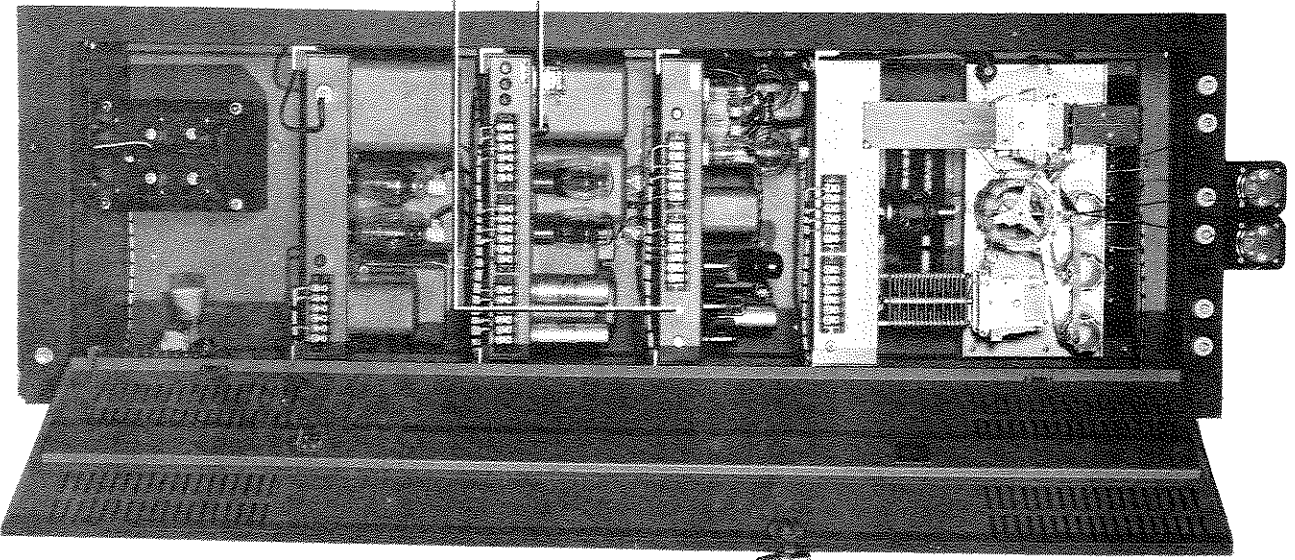
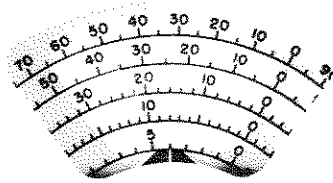
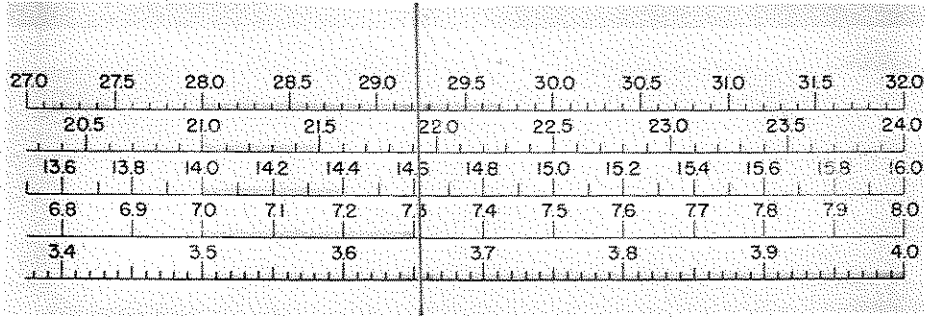
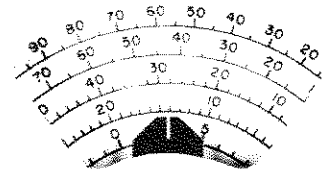
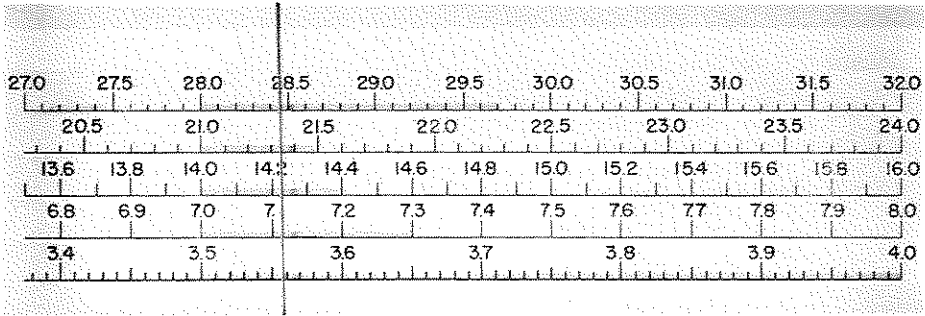

FIGURE 4-1 FUNCTIONS OF CONTROLS



FREQ.=3654 KC



FREQ.=7114 KC

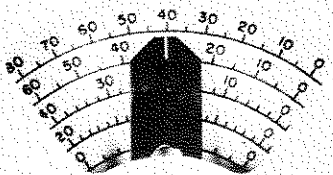
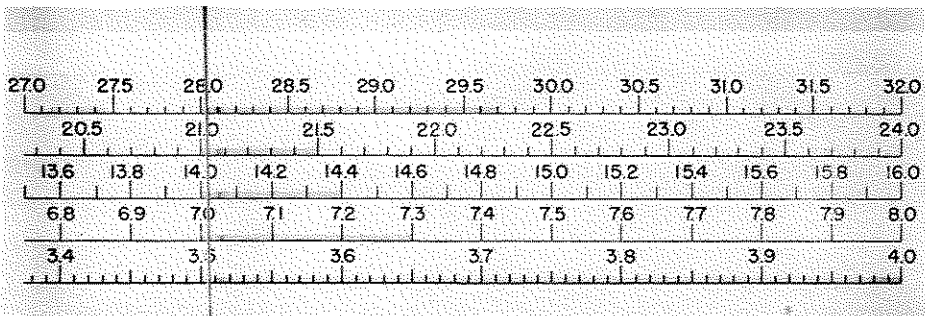

FREQ.=28040 KC

FIGURE 4-2 TYPICAL DIAL READINGS

OPERATION

(9) Rotate the TUNE-OPERATE switch to the OPERATE position and observe the PA PLATE CURRENT. If the plate current is more than 150 ma for phone operation or 200 ma for CW operation, reduce the antenna coupling with the ANTENNA COUPLING control. If the PA PLATE CURRENT is less than these values increase the coupling until the proper loading is obtained.

(10) After the tuning operations are completed, the audio gain control may be returned to the operating position.

6. SPEECH CLIPPER ADJUSTMENT.

a. SPEECH CLIPPER OUT.

(1) Reduce the AUDIO gain control until at normal speaking level, the MODULATOR PLATE current peaks should be less than 150 ma.

(2) If speech clipping is to be dispensed with entirely, remove the 6H6 Clipper tube. No harm will result other than the possibility of overmodulation.

b. SPEECH CLIPPER IN. - The point at which speech clipping occurs has been set at 100% modulation at the factory. The degree of speech clipping is raised by advancing the AUDIO GAIN Control clockwise.

NOTE

Advancing the AUDIO GAIN control will result in a greater amount of side-band power and higher background noise level, therefore a quiet operating position is desirable. Reducing the AUDIO GAIN will result in reduced side-band power and eventually a lower percentage of modulation. With the control set as furnished, any level of audio can be applied to the microphone without over modulating the transmitter.

7. CW OPERATION.

To operate the transmitter with continuous wave telegraphy emission, tune the transmitter as outlined in paragraph 5. b. in this section excepting that the plate current to the power amplifier may be increased to 200 ma.

For CW operation the PHONE-CW switch should be placed in the CW position and a telegraph key plugged into the KEY jack on the exciter unit front panel. Any speed of keying possible with a manually operated straight key or semi-automatic key may be employed.

OPERATION

8. TYPICAL METER READINGS.

a. CW OPERATION.

- (1) FILAMENT - 5 v
- (2) PA GRID CURRENT - 15 ma
- (3) PA PLATE CURRENT - 200 ma.

b. PHONE OPERATION.

- (1) MOD. PLATE CURRENT 45 ma (Static) 150 ma (100% no clipping)
- (2) FILAMENT - 5 v
- (3) PA GRID CURRENT - 15 ma
- (4) PA PLATE CURRENT - 150 ma